

WestminsterResearch

<http://www.westminster.ac.uk/westminsterresearch>

Application of Topological Operators over Data from InterCriteria Analysis

Roeva, O., Vassilev, P. and Chountas, P.

This is an author's accepted manuscript of an article published in Christiansen H., Jaudoin H., Chountas P., Andreasen T., Legind Larsen H. (eds) Flexible Query Answering Systems. FQAS 2017. Lecture Notes in Computer Science, vol 10333. Springer, Cham.

The final publication is available at Springer via:

https://dx.doi.org/10.1007/978-3-319-59692-1_19

The WestminsterResearch online digital archive at the University of Westminster aims to make the research output of the University available to a wider audience. Copyright and Moral Rights remain with the authors and/or copyright owners.

Whilst further distribution of specific materials from within this archive is forbidden, you may freely distribute the URL of WestminsterResearch: (<http://westminsterresearch.wmin.ac.uk/>).

In case of abuse or copyright appearing without permission e-mail repository@westminster.ac.uk

Generalized Net Model of Muscle Pain Diagnosing

Simeon Ribagin¹, Panagiotis Chountas², Tania Pencheva¹

¹Institute of Biophysics and Biomedical Engineering,
Bulgarian Academy of Sciences, Sofia, Bulgaria

`sim.ribagin@mail.bg`, `tania.pencheva@biomed.bas.bg`

²University of Westminster, Faculty of Science and Technology,
FST, Dept. of Computer Science, London, UK

`P.I.Chountas@westminster.ac.uk`

Abstract. Pain is the most common symptom of the many musculoskeletal pathologies. Musculoskeletal pain affects the muscles, ligaments, tendons, nerves and bones and might be caused by diverse factors. Musculoskeletal pain ranges from mild to severe. It can be local or diffuse, and acute or chronic. Due to the wide range of conditions that may cause such a symptom, diagnosing process is challenging and a systematic approach is necessary. In this investigation we present a successful example of generalized nets application in medical diagnosing and propose a novel approach leading to the appropriate diagnostic considerations. The method proposed in this investigation accurately identifies the various steps during the muscle pain diagnosing process and significantly improves the health care level. Obtained so far results could be used to assist in the decision making in the diagnostic processes.

Keywords: Musculoskeletal Pain, Generalized Nets

1 Introduction

The diagnosis of musculoskeletal pain is made on the basis of the medical history, clinical examinations, diagnostic imaging techniques and simple laboratory investigations. The basic issue associated with muscle pain diagnosing is to find the early pointers to a likely diagnosis. Then as part of the assessment, it is essential to establish a logical step-by-step approach to the medical history as well as a series of screening investigations. Muscle pain may arise due to injury or overexertion, infections, inflammatory or systemic conditions. A number of conditions can be associated with muscle pain, such as viral infections, fibromyalgia, autoimmune disorders, drug-induced disorders, metabolic disorders, etc. The purpose of the present study is to give an example how the apparatus of generalized nets might be successfully applied to medical diagnosing and as such to be proposed as a novel mathematical approach for diagnosing the causes of the muscle pain. Generalized nets (GNs) (see [1], [2]) are an apparatus for modeling of parallel and concurrent processes, developed as an extension of the concept of Petri nets

and some of their modifications. In general, the GNs may or may not have some of the components in their definition. GNs without some of their components form special classes called reduced GNs [2]. The presented GN-model shows similar features with previous models for medical diagnosing [3–5] but this is the first one highlighting the diagnostic algorithm for patients with muscle pain.

2 Generalized Net Model of Muscle Pain Diagnosing

A reduced GN-model which represents the plan for muscle pain diagnosing is developed here. The proposed GN-model is shown in Fig. 1.

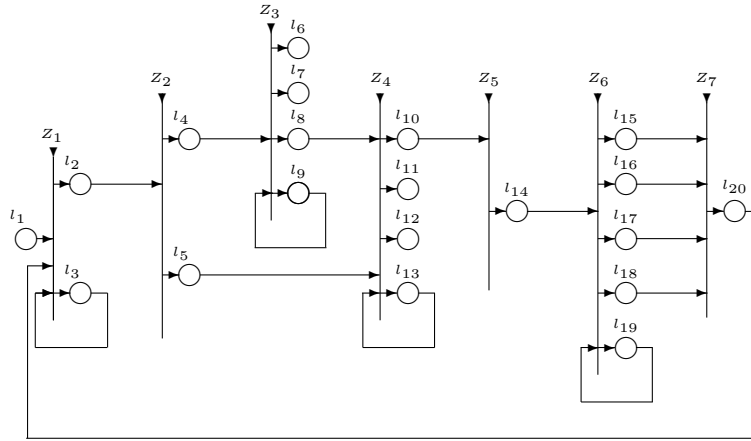

Figure 1. GN-model of muscle pain diagnosing

The GN-model has 7 transitions and 20 places with the following meanings:

- Z_1 represents the personal data of the patient;
- Z_2 – the current localization of the symptoms;
- Z_3 – the results from the medical history;
- Z_4 – the results from the physical examination;
- Z_5 – the set of laboratory tests;
- Z_6 – the results from the laboratory tests and possible diagnosis;
- Z_7 – the final diagnosis.

The GN-model contains 5 types of tokens: α , β , μ , ν and π . Some of the model transitions contain the so called “special place” where a token stays and collects information about the specific parts of the diagnosing process which are represented as follows:

- place l_3 collects the overall information obtained from the diagnostics steps in the personal record (personal data);
- place l_9 – information obtained from the history of the patient;
- place l_{13} – information about the results from physical examinations;
- place l_{19} – information about the results from the laboratory tests.

During the GM-model functioning, the α -tokens will unite with the tokens from the other types: β , μ , ν and π . After that, some of these tokens can split in order to generate new α -tokens obtaining corresponding characteristics. When there are some α -tokens (α_1 , α_2 , α_3 and, eventually, α_4), on the next time-moment all they will unite with a token from another type.

The token α enters the net in place l_1 with an initial characteristic:

“patient with muscle pain”.

The transition Z_1 has the following form:

$$Z_1 = \langle \{l_1, l_3, l_{20}\}, \{l_2, l_3\}, r_1 \rangle$$

where

$$r_1 = \begin{array}{c|cc} & l_2 & l_3 \\ \hline l_1 & false & true \\ l_3 & W_{3,2} & true \\ l_{20} & false & true \end{array}$$

- $W_{3,2}$ = *“information about the current symptoms, medical history and physical examination is necessary”.*

The tokens from the three input places of transition Z_1 enter place l_3 and unite with token β with the above mentioned characteristic. On the next time-moment, token β splits to two tokens – the same token β and token α_1 . When predicate $W_{3,2}$ is true, the token α_1 enters place l_2 and there it obtains a characteristic:

“obtain information about the current symptoms, medical history and physical examination”.

The transition Z_2 has the following form:

$$Z_2 = \langle \{l_2\}, \{l_4, l_5\}, r_2 \rangle$$

where

$$r_2 = \begin{array}{c|cc} & l_4 & l_5 \\ \hline l_2 & W_{2,4} & W_{2,5} \end{array}$$

and

- $W_{2,4}$ = “the muscle pain is local”;
- $W_{2,5}$ = “the muscle pain is diffuse with no history of trauma, overuse and stress”.

When the predicate $W_{2,4}$ is true, token α_1 enters place l_4 and there it obtains a characteristic:

“obtain information from the medical hystory of the patient”.

When the predicate $W_{2,5}$ is true, token α_1 enters place l_5 and there it obtains a characteristic:

“perform physical examination”.

The transition Z_3 has the following form:

$$Z_3 = \langle \{l_4, l_9\}, \{l_6, l_7, l_8, l_9\}, r_3 \rangle$$

where

$$r_3 = \frac{l_6 \quad l_7 \quad l_8 \quad l_9}{l_4 \mid \begin{array}{cccc} \text{false} & \text{false} & \text{false} & \text{true} \\ l_9 \mid W_{9,6} & W_{9,7} & W_{9,8} & \text{true} \end{array}}$$

and

- $W_{9,6}$ = “there is a history of trauma”;
- $W_{9,7}$ = “there is a history of recent overexertion and stress ”;
- $W_{9,8}$ = $\neg W_{9,6} \vee \neg W_{9,7}$.

The tokens from all input places of transition Z_3 enter place l_9 and unite with token μ with the characteristic as mentioned above. On the next time-moment, token μ splits to two tokens – the same token μ that stays permanently in the place l_9 , and token α_1 . When the predicate $W_{9,6}$ is true, token α_1 enters place l_6 and there it obtains a characteristic:

“consider: muscle contusion, muscle strain, muscle rupture, ligament sprain;
send patient to X-ray and/or MRI to determine the extent of the injury or to
identify possible additional injuries”.

When the predicate $W_{9,7}$ is true, token α_1 enters place l_7 and there it obtains a characteristic:

“consider: muscle cramps or delayed onset muscle soreness”.

When the predicate $W_{9,8}$ is true, token α_1 enters place l_8 and there it obtains a characteristic:

“perform physical examination”.

The transition Z_4 has the following form:

$$Z_4 = \langle \{l_5, l_8, l_{13}\}, \{l_{10}, l_{11}, l_{12}, l_{13}\}, r_4 \rangle$$

where

$$r_4 = \begin{array}{c|cccc} & l_{10} & l_{11} & l_{12} & l_{13} \\ \hline l_5 & false & false & false & true \\ l_8 & false & false & false & true \\ l_{13} & W_{13,10} & W_{13,11} & W_{13,12} & true \end{array}$$

and

- $W_{13,10} =$ “*there is muscle weakness without loss of muscle mass*”;
- $W_{13,11} =$ “*there is muscle weakness and loss of muscle mass*”;
- $W_{13,12} = \neg W_{13,10}$.

The tokens from all input places of transition Z_4 enter place l_{13} and unite with token ν with the characteristic as mentioned above. On the next time-moment, token ν splits to two tokens – the same token ν that stays permanently in the place l_{12} , and token α_1 . When the predicate $W_{13,10}$ is true, token α_1 enters place l_{10} and there it obtains a characteristic:

“perform a laboratory tests to rule in potential pathologies associated with muscle pain and weakness”.

When the predicate $W_{13,11}$ is true, token α_1 enters place l_{11} and there it obtains a characteristic:

“consider: muscular dystrophy; perform: muscle biopsy, aldolase test, creatine phosphokinase test”.

When the predicate $W_{13,12}$ is true, token α_1 enters place l_{12} and there it obtains a characteristic:

“consider: fibromyalgia, psychological disorders, spinal disorders, endocrine disorders, polymyalgia rheumatica”.

The transition Z_5 has the following form:

$$Z_5 = \langle \{l_{10}\}, \{l_{14}\}, r_5 \rangle$$

where

$$r_5 = \frac{}{l_{10}} \Big| \begin{array}{c} l_{14} \\ true \end{array}$$

The token from place l_{10} of transition Z_5 enter place l_{13} and there it obtains a characteristic:

“perform: erythrocyte sedimentation rate (ESR) test, serum alkaline phosphatase (SAP) test, creatine phosphokinase (CPT) test”.

The transition Z_6 has the following form:

$$Z_6 = \langle \{l_{14}, l_{19}\}, \{l_{15}, l_{16}, l_{17}, l_{18}, l_{19}\}, r_6 \rangle$$

where

$$r_6 = \begin{array}{c|ccccc} & l_{15} & l_{16} & l_{17} & l_{18} & l_{19} \\ \hline l_{14} & false & false & false & false & true \\ l_{19} & W_{19,15} & W_{19,16} & W_{19,17} & W_{19,18} & true \end{array}$$

and

- $W_{19,15}$ = “erythrocyte sedimentation rate (ESR) is high”;
- $W_{19,16}$ = “serum alkaline phosphatase (SAP) is high”;
- $W_{19,17}$ = “creatinine phosphokinase (CPT) is high”;
- $W_{19,18}$ = $\neg W_{19,15} \vee \neg W_{19,16}$.

The tokens from all input places of transition Z_6 enter place l_{19} and unite with token π with the characteristic as mentioned above. On the next time-moment, token π splits to two tokens – the same token π that stays permanently in the place l_{19} , and token α_1 . When the predicate $W_{19,15}$ is true, token α_1 enters place l_{15} and there it obtains a characteristic:

“consider: polymyalgia rheumatica, systemic lupus erythematosus, myositis or secondary carcinomatosis”.

When the predicate $W_{19,16}$ is true, token α_2 enters place l_{16} and there it obtains a characteristic:

“consider: liver diseases, osteoporosis, osteomalacia, viral infections, Pagets disease and hyperparathyroidism”.

When the predicate $W_{19,17}$ is true, token α_3 enters place l_{17} and there it obtains a characteristic:

“consider: drug-induced disorders, inflammatory myopathies”.

When the predicate $W_{19,18}$ is true, token α_4 enters place l_{18} and there it obtains a characteristic:

“consider: hypothyroidism, fibromyalgia, psychogenic causes, myofascial pain syndrome”.

The transition Z_7 has the following form:

$$Z_7 = \langle \{l_{15}, l_{16}, l_{17}, l_{18}\}, \{l_{20}\}, r_7 \rangle$$

where

$$r_7 = \begin{array}{c|c} & l_{20} \\ \hline l_{15} & true \\ l_{16} & true \\ l_{17} & true \\ l_{18} & true \end{array}$$

The tokens from the input places of transition Z_7 enter place l_{20} and unite in one token β_1 with some of the characteristics obtained from the previous time-step. The token β_1 returns to transition Z_1 and enters to place l_3 to extend the personal record of the current patient.

3 Conclusions

The so described GN-model may provide a framework that can be used by primary care practitioners to guide diagnostic processes for patients with muscle pain, enabling more accurate and efficient identification of conditions that may lead to pain in the muscles and would assist in optimizing patient outcomes and more effective treatment. The presented in this paper GN-model of diagnostic algorithm for patient with muscle pain is a part of a series of studies for diagnosing through GN-modeling assistance and can be improved in multiple ways to yield better results. This model significantly improves the accuracy of the primary diagnosis and the reliability of the proposed algorithm.

Acknowledgements

Work presented here is partially supported by the Grants: DFNP-142/2016 “Program for career development of young scientists, BAS” and DN02/10 “New Instruments for Knowledge Discovery from Data, and Their Modelling”

References

- [1] Atanassov, K.: Generalized Nets. World Scientific, Singapore (1991)
- [2] Atanassov, K.: On Generalized Nets Theory. Prof. M. Drinov Academic Publishing House, Sofia (2007)
- [3] Ribagin, S., Atanassov, K., Shannon, A.: Generalized Net Model of Shoulder Pain Diagnosis. Issues in Intuitionistic Fuzzy Sets and Generalized Nets 11, 55-62 (2014)
- [4] Ribagin, S., Roeva, O., Pencheva, T.: Generalized Net Model of Asymptomatic Osteoporosis Diagnosing. Proc. of 2016 IEEE 8th International Conference on Intelligent Systems (IS), Sofia, 604-608 (2016)
- [5] Shannon, A., Sorsich, J., Atanassov, K., Nikolov, N., Georgiev, P.: Generalized Nets in General and Internal Medicine, Vol. 1, Prof. M. Drinov Academic Publishing House, Sofia (1998)