



5th

European Meeting of the
International Society for
Microbial Electrochemistry
and Technology

**13th - 15th
September**

ONLINE





*Scientific
& Organizing*
COMMITTEES

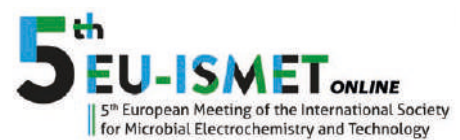

Organizing COMMITTEE



Maria D Balaguer



Lluís Bañeras



Teresa Bosch



Alba Cabrera



Jesús Colprim



Raquel Garcia



Albert Magrí



Helena Matabosch



Hèctor Monclús



Narcís Pous



Sebastià Puig

Scientific COMMITTEE



Lars Angenent



Federico Aulenta



Juan A Baeza



Belén Barroeta

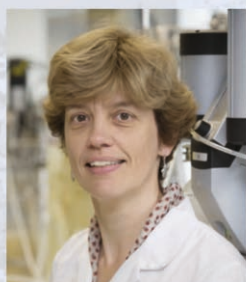

Heleen De Wever



Abraham Esteve Núñez



Sarah Glaven



Ola Gomaá



Albert Guisasaola



Falk Harnisch



Bruce Logan



Deepak Pant



Catarina Paquete



Korneel Rabaey



Miriam Rosenbaum



Pascal E. Saikaly



Annemiek ter Heijne



Marianna Villano



Bernardino Virdis



Eileen Yu

Keynotes

Synthetic biology for electroactive marine bacteria



**Lina J. Bird¹, Daniel A. Phillips², Dasha Leary¹, Matthew D. Yates¹,
Leonard M. Tender¹, Christopher A. Voigt³, Sarah M. Glaven¹**

¹Center for Bio/Molecular Science and Engineering, Naval Research Laboratory, 4555 Overlook Ave SW, Washington, DC 20375

²Oak Ridge Institute for Science and Education / US Army DEVCOM Chemical Biological Center, Biochemistry Branch, Aberdeen Proving Grounds, MD

³Department of Biological Engineering and the Synthetic Biology Center, Massachusetts Institute of Technology, Cambridge, MA, USA

Harnessing and controlling extracellular electron transfer pathways using bioengineering and synthetic biology promises to heighten the limits of established technologies and open doors to new possibilities. Synthetic biology is a powerful tool which nevertheless has limitations when applied to environmentally relevant organisms. Most synthetic biology parts are developed in *E. coli*, a model organism that grows well in the lab but poorly in the environment, especially in marine conditions. We have taken synthetic biology tools developed for *E. coli* and adapted them to *Marinobacter atlanticus*, a chassis that thrives under a wide range of conditions. Here, we present a three dimensional-printed flow cell for simultaneous electrochemistry and fluorescence imaging. Current-producing biofilms of *Marinobacter atlanticus* constitutively expressing green fluorescent protein were grown on the flow cell working electrode. Increasing current corresponded with increasing surface coverage and was comparable to biofilms grown in typical stirred-batch reactors. An isopropyl β -D-1-thiogalactopyranoside (IPTG) inducible system driving yellow fluorescent protein was used to assess the spatiotemporal activation of protein expression within the biofilm at different stages of growth and induction dynamics. We then used these tools to refactor a well-studied extracellular electron transfer system from *Shewanella oneidensis* and used it to program *M. atlanticus* for electronic communication with an electrode. In doing so, we gained a deeper understanding of the requirements of an inducible bioelectrochemical system, which could not have been determined from either homologous refactoring of the system, or expression of the system in traditional lab chassis.

Keynotes

Industrial biotechnology for CO₂ conversion

Heleen De Wever



Europe wants to become the first climate neutral continent by 2050 and aims at a 55% greenhouse gas emission reduction by 2030. To reach this challenging goal, decarbonization is a good strategy for energy and transport but not for chemicals and materials which are largely carbon based. A first part of the presentation will focus on renewable carbon as a means to cover future (increasing) carbon demand. The second part will zoom in on the renewable carbon source CO₂ and Carbon Capture and Utilization (CCU) strategies. The third part will discuss industrial biotechnology for CO₂ conversion, its claimed benefits and current challenges with indications on desired features. Examples will be included from research work and industrial scale experience.

Keynotes

Mediator-Based Electroactivity for Biotechnological Applications



Miriam A. Rosenbaum

Leibniz-Institute for Natural Product Research and Infection
Biology - Hans-Knöll-Institute, Germany

Miriam.rosenbaum@leibniz-hki.de

Microbial extracellular electron transfer via self-produced diffusible redox-mediators has some significant advantages for biotechnology over direct electron transfer pathways. Most importantly, it is not dependent on a 2-dimensional electrode biofilm and it can enable also other microbial community partners to engage in extracellular electron transfer and. However, today, electron transfer via redox-mediator is much less efficient for the microorganisms than direct electron transfer and does not yield ATP for the cells.

One of the best known producers of natural redox-mediators is *Pseudomonas aeruginosa*, which produces phenazine-type mediators. Isolated from several wastewater treating microbial fuel cells it showed synergistic electroactivity relationships with the fermenter *Enterobacter aerogenes*. Thereby, *Enterobacter* stimulates phenazine synthesis in *P. aeruginosa* and in turn uses these mediators much more efficiently than *Pseudomonas* for anaerobic respiration with the anode. Our goal is to investigate the use of phenazines in both organisms with the longterm aim to reconstruct energy yielding mediator-based respiration in biotech production strains.

In past years, we investigated this phenazine-based synergistic electroactivity in detail. Interestingly, the co-culture stimulation is also found for other 2,3-butanediol fermenters. However, the synergism is only partly determined by the fermentation product 2,3-butanediol and also other molecular factors are involved. Further, environmental factors, especially oxygen, can be used to steer co-culture performance, phenazine production and electroactivity. On a molecular basis, phenazine production is highly controlled and we deciphered strong antagonistic regulation of the different phenazine synthesis genes. A big factor for a limited phenazine usage in *P. aeruginosa* could be the access of phenazines to electron donating metabolic steps. Our recent work, confirms a significant phenazine reduction already in the periplasm but also shows that oxidized phenazines can indeed reenter the cell.

We are now applying our molecular understanding of phenazine synthesis, regulation, and molecular physiology towards a heterologous utilization of phenazines for mediator-based microbial electrocatalysis.

Monday,

13th,

Tuesday,

14th

Wednesday,

15th

September 2021

PROGRAMME

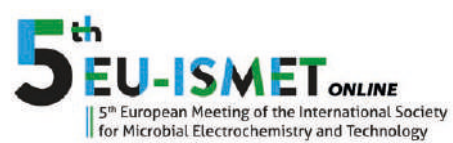

13th - 15th September 2021

Main Room

9:00-12:30 EU-ISMET WORKSHOP

9:00-9:15 Welcome session

Chair: *Narcís Pous*

9:00-09:50 W1: Introduction to microbialelectrochemistry: fundamentals and characterization tools. *Bernardino Virdis* (University of Queensland)

10:00-10:50 W2: On the thermodynamics of electroactive microorganisms

Benjamin Korth (Helmholtz Center for Environmental Research)

11:00-11:50 W3: How basic biology research can inspire us to innovate in microbial electrochemistry. *Sara Tejedor-Sanz* (Rice University)

12:00-12:30 Separated meetings for screen-to-screen discussion with workshop speakers (**Networking area**)

14:00-14:30 Opening ceremony

Annemiek ter Heijnen & Sebastià Puig

14:30-15:10 Plenary: "Mediator-based electroactivity for biotechnological applications"

Miriam Rosebaum

15:15-16:35 Parallel Session 1: Fundamentals of the electron transfer processes

Chair: *Catarina Paquete*

In situ and non-destructive real time microscopic investigation of multi-species electroactive biofilms on transparent microfluidic BES. *Lucila Martinez Ostormujof*

La persistència de l'entropia: Measuring the microbial electrochemical Peltier heat of different electrode materials. *Benjamin Korth*

Role of phenazine-enzyme physiology for current generation in a bioelectrochemical system.

Anthony Chukwubuikem

Exploration of the reactivity of multiheme cytochromes and how it can be improved for (bio)electrocatalysis.

Ricardo Louro

Degustació de pernil a diferent voltatge de l'ànode: The influence of the anode potential on single cell yield coefficient of *Geobacter sulfurreducens*.

Francesco Scarabotti

16:35 – 16:45 Coffee Brea

16:45-18.05 Parallel Session 3: Fundamentals of the electron transfer processes

Chair: *Lluís Bañeras*

Crossing the wall: extracellular electron transfer in Gram-positive bacteria.

Catarina Paquete

Extracellular electron transfer in a C. ljungdahlii-based platform for microbial electrosynthesis.

Santiago Treceño Boto

Bioelectrochemical characterization of a cytochrome belonging to the NapC/NirT family from *Sideroxydans lithotrophicus* ES-1.

Anáisa Coelho

Charge transfer parameters through biofilms of an enhanced current-producing *Geobacter sulfurreducens* strain reveal increased electron transfer diffusion rate.

Fernanda Jimenez Otero

Electron uptake in MES: How does *Sporomusa ovata* accept electrons at the cathode?.

Joana Madjarov

18:05-19:00 Social event. Girona guided tour

Note: The time zone is UTC+2.

**Monday,
13th**
September 2021

Room 2

15:15-16:35 Parallel Session 2: Commercialisation, Scale-up of METs

Chair: *Esteve Núñez Abraham*

Scaling Up of Electro-Stimulated Anaerobic Reactor (ELSARTM) in the industrial wastewater treatment sector.

Antonio Gimenez Lorang

Competitive advantages of a circular bioeconomy based on microbial electrosynthesis and CO₂.

Jamin Wood

IoT biosensing: a microbial electrochemical sensor for monitoring water quality.

Antonio Berna

Wastewater treatment with a 1000 L microbial fuel cell: a 16-month experience.

Fabian Fischer

Role of the C/N ratio in the feeding solution of a micro pilot microbial electrolysis cell aimed at biogas upgrading.

Lorenzo Cristiani

16:45-18.05 Parallel Session 4: Commercialisation, Scale-up of METs

Chair: *Juan Antonio Baeza Labat*

Full scale operation of decentralized urban wastewater using METland® technology.

Abraham Esteve-Núñez

Development of Innovative Soil Microbial Fuel Cells for Energy Harvesting.

Jakub Dziegielowski.

Increasing the voltage in series-stacked bioelectrochemical systems, a road towards technology up-scaling.

Pau Bosch-Jimenez

Life cycle assessment of Microbial Electrosynthesis.

Siddharth Gadkari

MIDES H2020 Project: Microbial Desalination for Low Energy Drinking Water. From lab-scale concept to Pilot Plant validation.

Juan Manuel Ortiz

16:30-16:45 Coffee Break

**Monday,
13th**
September 2021

Main Room

8:30-9:10 Plenary: "Industrial biotechnology for CO₂ conversion"

Heleen De Wever

Chair: *Sebastià Puig*

9:15-10:35 Parallel Session 5: Microbial electrosynthesis and electro-fermentation

Chair: *Eileen Yu*

Insights in the electro-fermentation process with ¹³C-labelled experiments supported by NMR spectroscopy analysis.

Gaia Salvatori

Experimental optimization of long chain fatty acids synthesis from CO₂ using statistical design.

Narnepati Krishna Chaitanya.

Enhancing butanol production by *Clostridium beijerinckii* through cathodic electro-fermentation approach.

Daniele Molognoni

Statistical analysis on factors affecting microbial electrosynthesis (MES).

Lakshmi Pathi Thulluru

Voleu crear models per fer una drecera? Development of a model for microbial electrosynthesis with planktonic cells and mediator based electron transfer.

Johannes Nelles

10:35 – 10:45 Coffee Break

10:45-12:20 Parallel Session 8: Microbial electrosynthesis and electro-fermentation

Chair: *Marianna Villano*

Bioinorganic electrosynthesis of single-cell protein from CO₂ and green electricity.

Mingyi Xu

Alliance of microbial electrochemical technologies and fermentation for the conversion of carbon dioxide into elongated chemical building blocks.

Meritxell Romans Casas

3D bioprinted MES biofilms enhancing the acetate production rate of *Sporomusa ovata*.

Adolf Krige

Towards bioelectrochemical degradation of hydrophobic wastes coupled with synthesis of biosurfactants.

Grzegorz Pasternak

In-situ production of microbial protein with reclaimed ammonium in a microbial electrochemical recovery conversion cell.

Xiaoyong Yang

Biogas upgradation through CO₂ conversion into acetic acid via microbial electrosynthesis.

Moumita Roy

12:25-13:00 Plenary session: Horizon Europe

Lydia González

Chair: *Sebastià Puig*

13:00-14:00 Lunch

**Tuesday,
14th**
September 2021

Main Room

14:00-14:40 Plenary session: Synthetic biology for electroactive marine bacteria

Sarah Glaven

Chair: *Sebastià Puig*

14:45-16:05 Parallel Session 11: Electro-microbiology

Chair: *Ricardo O Louro*

Competition of two highly specialized and efficient acetoclastic electroactive bacteria for acetate in biofilm anode of microbial electrolysis cell.

Krishna Katuri

Enhancing power generation and biocompatibility exo-electrogenic bacteria in microbial fuel cell using NiWO₄/rGO as anode electro-catalyst and optimized process parameter.

Geetanjali

Haloalkaliphilic nitrate-reducing electroactive microbial biofilm enriched from the Lonar Lake sediments.

Srishti Chaudhary

The “electro-fermentation effect” of *Geobacter sulfurreducens* co-cultured with *Clostridium pasteurianum* is not induced by electron transfer.

Elie Desmond-Le Quéméner

Design of electroactive bacteria by coupling genetic networks to redox environments.

Angel Goñi-Moreno

16:05-16:15 Coffee Break

16:15-17:30 Parallel Session 13: Electro-microbiology

Chair: *Luis Bañeras Vives*

La última batalla: Interaction between *Geobacter* spp. dominated biofilms and anaerobic digestion effluents.

Daniel Dzofou Ngoumelah

Bacteria coated cathodes as an in-situ hydrogen evolving platform for Microbial Electrosynthesis.

Elisabet Perona-Vico

Selection and enrichment of electroactive microbial communities for removal of pharmaceuticals in microbial electrochemical systems.

Razieh Rafieenia

How can microbial heat help in optimising the energy conversion of Microbial Electrochemical Systems (MES)?

Pavlina Theodosiou

17:30-18:00 ISMET event - News

**Tuesday,
14th**
September 2021

Room 2

9:15-10:35 Parallel Session 6: Microbial electrosynthesis and electro-fermentation

Chair: *Lars Angenent*

Theory of transport and recovery in microbial electrosynthesis of acetate from CO₂.

Jouke Dykstra

Power-to-algae: carbon dioxide to bio-oil in a BES-supported microalgae biorefinery.

Silvia Bolognesi

Screening for hyperthermophilic electroautotrophs for the microbial electrosynthesis of organic compounds.

Guillaume Pillot

Characterization of fluidized vs. fixed granular activated carbon beds as cathodes for microbial electrosynthesis of carboxylates from CO₂.

Igor Vassilev

Insights into electro-fermentation of caproate from CO₂ and ethanol.

Laura Rovira-Alsina

10:35-10:45 Coffee Break

10:45-12:20 Parallel Session 9: Microbial electrosynthesis and electro-fermentation

Chair: *Marika Kokko*

CO₂ conversion by combining a Cu electrocatalyst and microorganisms.

Konstantina-Roxani Chatzipanagiotou

Biocathode and photoanode development for solar energy-driven microbial electrosynthesis.

Paolo Dessi

A general model for biofilm-driven microbial electrosynthesis of carboxylates from CO₂.

Oriol Cabau Peinado

The impact of cathode acclimation methods on electro-trophic biofilm formation and performance of electromethanogenic cells.

Amin Ghaderikia

Bioelectrosynthesis of organic acids from CO₂ using fluidized bed electrodes in a 3 phase reactor.

María Llorente Remartínez

Strategies for increasing production of bio-products from CO₂ by Microbial electrosynthesis (MES).

Eileen Yu

13:00-14:00 Lunch

**Tuesday,
14th**
September 2021

Room 2

14:45-16:05 Parallel Session 12: Bioremediation, water treatment and resource recovery from waste

Chair: *Marco Zeppilli*

Large-scale literature meta-analysis: the impact of the bioelectrochemical process configurations on the electrochemical and wastewater treatment performances.

Roman Moscoviz

Filtrating Microbial Fuel Cells for biofertiliser and energy production.

Iwona Gajda

Exploring avoided environmental impacts and resource recovery from desalination brine through Microbial Desalination Cell treatment.

Rosa Anna Nastro

Optimization of filtering anodes for the integration of bioelectrochemical systems into anaerobic membrane bioreactors.

Pavari Viwatthanasittiphong

Comprehensive and long-term assessment of critical operational parameters of a pilot MEC for hydrogen production from urban wastewater.

Oscar Guerrero

16:05-16:15 Coffee Break

16:15-17:30 Parallel Session 14: Bioremediation, water treatment and resource recovery from waste

Chair: *Albert Guissaola*

Low energy consuming bioelectrochemical system for ammonium recovery from wastewater as liquid fertilizer.

Eduard Borràs

Ammonia recovery from digestates in a three-chambered bioelectrochemical system through hydrophobic membranes.

Miriam Cerrillo Moreno

Effect of hydraulic conditions in PFR reactors using bio-electrochemical processes to influence greenhouse gas emission.

Annegret Budach

Simulation of Pilot Scale Microbial Electrochemical Technologies.

Jordan Day

Note: The time zone is UTC+2.

**Tuesday,
14th
September 2021**

Room 3

9:15-10:35 Parallel Session 7: Novel applications of METs

Chair: *Tom Sleutels*

Biophotovoltaics for hydrogen production using cyanobacteria.

Bin Lai

Hyperthermophilic hydrogen production by iron reducing Archaea in microbial electrolysis cells (MECs).

Yasemin Dilsad Yilmazel

Electrifying biotrickling filters for the treatment of aquaponics wastewater.

Narcis Pous

Metabolic Pathway Involved in CO₂ Fixation under Photo-Bioelectrochemical conditions by a Purple Phototrophic Bacteria Biofilm.

Sara Díaz-Rullo Edreira

10:35-10:45 Coffee Break

10:45-12:20 Parallel Session 10: Novel applications of METs & MET-based sensor technology

Chair: *Annemiek Ter Heijne*

Bidirectional microbial biofilms with sulfur based energy storage.

Paniz Izadi

Bioenergetic and biotechnological implications of extracellular electron transfer in lactic acid bacteria.

Sara Tejedor Sanz

Microbial activity and biomass monitoring in freshwater ecosystems using a MEC-based biosensor.

Marta Fernandez-Gatell

Microbial Electrochemical Systems: Principles, Construction and Biosensing Applications.

Rabeay Hassan

Biocathodes with graphene oxide coatings enhance methane production

Daniela Carrillo

Note: The time zone is UTC+2.

**Tuesday,
14th**
September 2021

Main Room

8:30-9:10 Plenary: Microbial electrochemistry for bioremediation: the game changer

Korneel Rabaey

Chair: *Sebastià Puig*

9:15-10:35 Parallel Session 15: Bioremediation, water treatment and resource recovery from waste

Chair: *Uwe Schröder*

Desalination of Brackish Water Using a Microbial Desalination Cell: analysis of the electrochemical behaviour.

Marina Ramirez

Electrobioremediation by METland® solution differentiates among enantiomers in mixtures of pharmaceuticals and herbicides.

Álvaro Pun García

Development of a four-chamber microbial desalination cell for simultaneous treatment of Cr (VI) containing wastewater and by-products recovery.

MD Tabish Noori

Electrobioremediation of Pharma pollutants is boosted in a Microbial Electrochemical Fluidized Bed Reactor.

Yeray Asensio

Bioelectrochemical dechlorination of 1,2-dichloropropane by a Dehalogenimonas-enriched culture. David Juan Fernández Verdejo

10:30-10:45 Coffee Break

10:45-12.20 Parallel Session 17: Bioremediation, water treatment and resource recovery from waste

Chair: *Pascal Saikaly*

Groundwater denitrification by expanded bioelectrochemical systems. *Xiaofei Wang*

Combined electrochemical water softening and nitrate electro bioremediation. *Alba Ceballos-Escalera*

Electro-bioremediation of nitrate from saline groundwater and concomitant chlorine production. *Giulia Puggioni*

Soil Microbial Fuel Cell for Bioremediation of Recalcitrant Hydrocarbons. Arpita Nandy

Simultaneous removal of oxidable and reducible contaminants from groundwater with the "bioelectric well". *Matteo Tucci*

Power Generation from Constructed Wetland Microbial Fuel Cells under Batch and Continuous Flow. *María G. Salinas-Juárez*

12:20-13:00 Round Table on "electro-bioremediation"

Chair: *Korneel Rabaey*

13:00-14:00 Lunch

Wednesday,
15th
September 2021

Main Room

14:00-14:40 Eu-ISMET goes to high schools

Maria Teresa Bosch Vilardell, Narcís Pous and Miquel Àngel Ruiz

Chair: *Belén Barroeta*

14:45-16:00 Parallel Session 19: Materials science and design

Chair: *Falk Harnisch*

Magnetite anodes to inhibit oxygen production and to circumvent the use of membranes in microbial electrosynthesis.

Nils Rohbohm

Procedure for the screening of anode materials for microbial electrolysis cells operated with brewery wastewater.

Isaac Vázquez

Promising affordable separators for microbial electrolysis cells.

Oscar Santiago

Towards improving the performance of microbial fuel cells: Evaluation of inoculation strategies and anode materials.

Zainab Ul Kausar

Metal-free activated biochar as an oxygen reduction reaction catalyst in single chamber microbial fuel cells.

Tommy Pepè Sciarria

16:00-16:10 Coffee Break

16:10 - 17:30 Parallel Session 21: Materials science and design

Chair: *Eduard Borrás*

Capacitive bioanodes in fixed and moving bed reactors.

Tom Sleutels

Graphene functionalization with metallic Pt nanoparticles: envisaging future cathodes for bioelectrochemical H₂ production.

Pilar Sánchez Peña

Development and upscaling of gas diffusion electrodes for wastewater treatment and electrosynthesis of chemicals.

Deepak Pant

Estructures superficiales com les d'Antoni Gaudi: Platinized titanium as cost-effective anode material for Kolbe electrolysis.

Katharina Neubert

17:35 - 18:00 Closing ceremony

Note: The time zone is UTC+2.

Wednesday,
15th
September 2021

Room 2

9:15-10:30 Parallel Session 16: Bioremediation, water treatment and resource recovery from waste

Chair: *Bernardino Viridis*

Purple phototrophic bacteria in microbial electrochemical fluidized-like bed reactors for brewery wastewater treatment. *Carlos Manchon*

Primary Sludge-Based Blackwater Favors COD Conversion to Electrons Over Methane in Microbial Electrochemical Cells. *Jessica Deaver*

Electrobioremediation of soil polluted with the insecticide Lindane. *Andres de Deus*

Gira a sofre: Disentangling the sulfur cycle in one- and two-chamber bioelectrochemical systems. *Shixiang Dai*

Treatment and reuse of wastewater based on METland® technology. *Lorena Peñacoba Antona*.

10:35-10:45 Coffee Break

10:45-12.20 Parallel Session 18: Bioremediation, water treatment and resource recovery from waste

Chair: *Mirella Di Lorenzo*

Taking the waste out of dye wastewater using microbial fuel cells. *Godfrey Kyazze*

Lowering energy consumption of a sequential reductive/oxidative bioelectrochemical process for CAHs removal by a galvanostatic polarization strategy. *Marco Zeppilli*

Chlorinated aliphatic hydrocarbons (CAHs) removal from a real groundwater by a sequential Reductive/Oxidative Bioelectrochemical process. *Edoardo Dell'Armi*

Modelling bioelectrochemical reactors for electrobioremediation processes development optimization. *Michele Mascia*

Bio-electrochemical degradability of prospective wastewaters to determine their ammonium recovery potential. *Steffen Georg*

13:00-14:00 Lunch

Wednesday,
15th
September 2021

Room 2

14:45-16:00 Parallel Session 20: Materials science and design

Chair: *Dessi, Paolo*

Magnetic resonance imaging as a tool for the analysis and optimization of electroactive biofilms inside porous electrode structures. *Luca Häuser*

Development and application of conductive nanomaterials for bioelectrochemical denitrification. *Magda Nechanická*

Influence of different photocatalytic dopants in the antifouling performance of Nanofiltration Microbial fuel cells. *Raul Bahamonde Soria*

The role of bioanode-membrane interlayer in tubular Ceramic Microbial Fuel Cells (CMFCs). *Jesús Rodríguez*

Power to Gas: newsworthy connection between electricity production trend, biochar electrodes and polarizations. *Andrea Goglio*

16:10-17:30 Parallel Session 22: General session

Chair: *Ola Gomaa*

The applicability of the Maximum Power-point of Microbial Fuel Cells: Influence of Potential Scan rate and real-time external Load. *Meshack Imologie Simeon*

Electrochemical characterization of the anodic biofilm activity in a methane-producing microbial electrolysis cell. *Marianna Villano*

The effect of the cathode current collector on the performance of a yeast-based air cathode microbial fuel cell. *Joana Vilas Boas*

Copla electroquímica: How sound is Electrochemical Impedance Spectroscopy on biofilm electrodes?. *Jörg Kretzschmar*

16:00-16:10 Coffee Break

Wednesday,
15th
September 2021



Oral presentations

5th EU-ISMET_{ONLINE}
| 5th European Meeting of the International Society
for Microbial Electrochemistry and Technology

13th - 15th September 2021

Biocathodes with graphene oxide coatings enhance methane production

D. Carrillo¹, R. Mateos¹, A. Morán¹, A. Escapa^{1,2,*}

¹ Chemical and Environmental Bioprocess Engineering Group, Natural Resources Institute (IRENA), Universidad de León, Avda. de Portugal 41, E-24009 Leon, Spain

² Department of Electrical Engineering and Automatic Systems, Campus de Vegazana s/n, Universidad de León, E-24071 León, Spain

*Email: adrian.escapa@unileon.es

Microbial electrosynthesis (MES) uses certain types of electroactive microorganisms to obtain commercially valuable products (such as methane, CH₄) from carbon dioxide (CO₂). The aim of this work is to quantify the impact that the electrodeposition of graphene oxide on a cathode has on methane production in a MES system. To that end, an H-type electrochemical cell was used, with four identical carbon felt electrodes placed in the cathodic chamber (Fig. 1). Two of these cathodes were electrodeposited with graphene oxide (goCF) and the other two electrodes were used as control (without modifications). In terms of productivity and bioelectrochemical performance, the current density produced by the goCF was 30% higher than the control electrode. Furthermore, with the help of cyclic voltammetry (CV) and electrochemical impedance spectroscopy (EIS) it was confirmed that goCF electrode had lower charge transfer resistances and up to twice as much electrical capacitance compared to the unmodified electrode. Finally, at a CO₂ feed rate of 15-30 g CO₂ per m² of electrode and per day, methane was produced at concentrations above 95%.

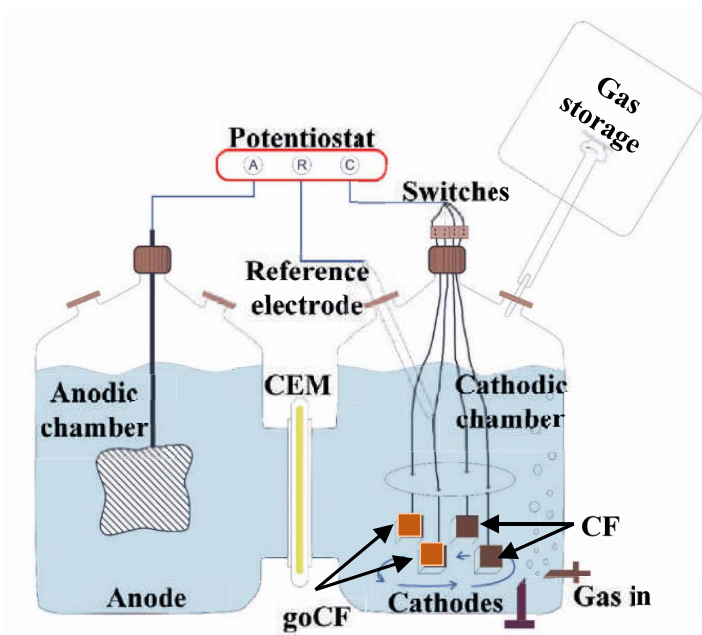

Fig. 1 Microbial electrosynthesis reactor (H-Cell MES) configuration.

Keywords: Biocathode, CO₂, graphene oxide, microbial electrosynthesis.

Funding: This research was possible thanks to the financial support of "Ente Regional de la Energía de Castilla y León" (No. EREN_2019_L3_ULE) and Project supported by 'Consejería de Educación de la Junta de Castilla y León' (No. LE320P18), a project co-financed by FEDER funds.

Microbial activity and biomass monitoring in freshwater ecosystems using a MEC-based biosensor

Marta Fernandez-Gatell^{1,2}, Xavier Sanchez-Vila^{2,3}, Jaume Puigagut^{1*}

¹ GEMMA – Environmental Engineering and Microbiology Research Group, Department of Civil and Environmental Engineering, Universitat Politècnica de Catalunya – BarcelonaTech, c/Jordi Girona 1-3, Building D1, E-08034 Barcelona, Spain

² Dept. of Civil and Environmental Engineering, Universitat Politècnica de Catalunya, c/ Jordi Girona 1-3, 08034 Barcelona, Spain

³ Associated Unit: Hydrogeology Group (UPC-CSIC), Spain

*Email: jaume.puigagut@upc.edu

Climate change is one of the most important and probable aspects influencing the stability of human societies [1]. Greenhouse gas (GHG) emissions from natural or human-made freshwater ecosystems are linked to the anaerobic microbial activity (MA) and influence the global GHG emissions and dynamics [2]. Thus, better tools regarding the characterization of both the MA and biomass within ecosystems is of capital importance to deal with climate change. However, MA and biomass assessment methodologies are complex and cannot be applied continuously. Bioelectrochemical systems (BES) produce a current from the anaerobic metabolic activity of electroactive bacteria that naturally inhabit water bodies. This study addresses the use of the bio-electric signal of BES to estimate the MA and the biomass of its surrounding area. To this purpose, four Microbial Electrolysis Cell (MEC) reactors were operated for 29 weeks under different MA and biomass conditions. Bio-electric signal was recorded continuously, while biomass content and MA (estimated through ATP and enzymatic activity) were weekly evaluated ($n = 6/\text{reactor}$). Results (Fig. 1) showed that the MEC bio-electric signal correlates with statistical significance with both the MA and biomass, demonstrating that MEC-based biosensors could be applied for continuous monitoring of MA and biomass in freshwater ecosystems.

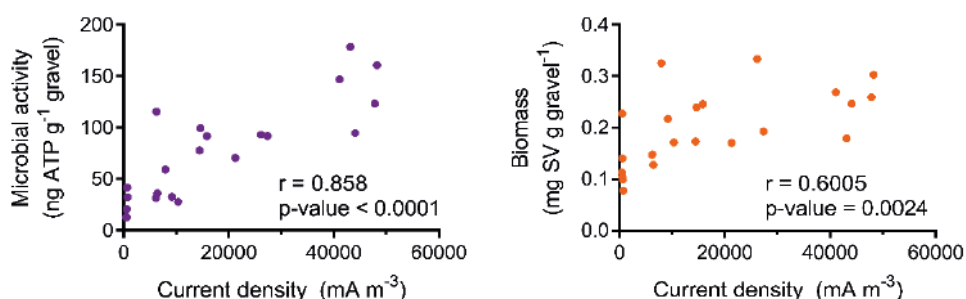

Fig. 1. Pearson's correlation results between current density from the MEC and biomass (left) and microbial activity (right).

Keywords: microbial activity, biomass, climate change, microbial electrolysis cell, biosensor

Funding: Ayudas para la promoción de empleo joven e implantación de la Garantía Juvenil en I+D+i (PEJ2018-

005586-A). Generalitat de Catalunya (Consolidated Research Group 2017 SGR 1029

References

[1] M. McLennan, 16th Edition *The Global*

Risks Report 2021 16th Edition Strategic Partners. World Economic Forum, 2021.

[2] P. Bousquet *et al.*, "Contribution of anthropogenic and natural sources to atmospheric methane variability," *Nature*, vol. 443, no. 7110, pp. 439–443, Sep. 2006.

Bioenergetic and biotechnological implications of extracellular electron transfer in lactic acid bacteria

Sara Tejedor-Sanz^{1,2}, Eric T. Stevens³, Maria L. Marco³ and Caroline M. Ajo-Franklin^{1,2}

¹Department of Biosciences, Rice University, 6100 Main St., Houston, United States, 77005

²Biological Nanostructures Facility, The Molecular Foundry, Lawrence Berkeley National Laboratory, 1 Cyclotron Road, Berkeley, United States, 94720

³Department of Food Science & Technology, University of California-Davis, 392 Old Davis Rd, Davis, United States, 95616

Extracellular electron transfer (EET) has been classically associated with respiratory species. However, EET has also been discovered across many fermentative microorganisms like lactic acid bacteria (LAB)¹. Because the bioenergetic implications are not understood, we explored the impact of EET in lactic acid fermentations employing *Lactiplantibacillus plantarum*, a LAB species found in insects, plants and mammals and essential to produce fermented foods. EET on anodes by *L. plantarum* is robust and alleviates constraints of intracellular redox balance during fermentation, generating a high NAD⁺/NADH ratio² however recent work shows some species can use mixed or alternative bioenergetic strategies. We explored the utility of a flavin-based extracellular electron transport (FLEET). This metabolic impact increases fermentation yield and flux and ATP production through substrate-level phosphorylation. This EET activity requires elements of an electron transport chain like an NADH dehydrogenase (Ndh2). Thus, EET in *L. plantarum* is a hybrid energy metabolism that blends metabolic features of fermentation and redox features of respiration. This pathway is active in physiologically niches like a food fermentation. Using *L. plantarum* as a starter culture in a kale juice electro-fermentation allows to increase the fermentation yield and acidification rate of the juice. Thus, the electroactivity of LAB also has relevant biotechnological implications as it can be used to prevent the growth of undesired microorganisms and to alter flavour and aromas in food matrices.

Keywords: lactic acid bacteria, fermentation, food, metabolism

Funding: National Science Foundation (#1650042) and Office of Naval Research (#0001418IP00037 (CMAF)). Work at the Molecular Foundry was supported by the Office of Science, Office of Basic Energy Sciences.

References

- [1]. Light, S. H. *et al.* A flavin-based extracellular electron transfer mechanism in diverse Gram-positive bacteria. *Nature* 562, 140–144 (2018).
- [2]. Tejedor-Sanz, S. *et al.* Extracellular electron transfer increases fermentation in lactic acid bacteria via a hybrid metabolism. *bioRxiv* 2021.

Bidirectional microbial biofilms with sulfur based energy storage

Paniz Izadi¹* Marten Niklas Gey¹ Nicolas Schlüter¹, Uwe Schröder¹

¹ Institute of Environmental and Sustainable Chemistry, Technische Universität Braunschweig, Hagenring 30, 38106 Braunschweig, Germany

*Email: p.izadi@tu-bs.de

Bidirectional microbial biofilms have been proposed as one of the potential applications of bio-electrochemical systems (BESs), in which a single biofilm can generate power and store energy. Here, we studied underlying mechanisms involved in bidirectional biofilms developed from German coasts of North Sea and Baltic Sea through an anodic cultivation strategy, followed by a periodic potential reversal regime. Community analysis from such efficient biofilms showed the enrichment of microorganisms with different metabolic pathways such as *Shewanella* and *Desulfovibrio* species, contributing in functioning as both bioanode and biocathode. Over the long term, the bidirectional activities of the biofilms were related to microbial electrosynthesis of hydrogen, formate and acetate during the cathodic polarity and consumption of the products during the anodic polarity. However, over the short term, the bidirectional activities of the biofilms seemed to be dominated by the electrochemical conversion of sulfur formed at the electrode surfaces through oxidation of biogenic sulfide ions and reduction of sulfur to sulfide (and polysulfide). The results can open opportunities towards using a single biofilm for energy storage and release in coastal areas.

Keywords: Bidirectional microbial biofilms, coastal samples, sulfur

Design of electroactive bacteria by coupling genetic networks to redox environments

Lewis Grozinger¹, Elizabeth Heidrich², Angel Goni-Moreno^{3,1,*}

¹School of Computing, Newcastle University, Urban Sciences Building, Newcastle-upon-Tyne, NE4 5TG

²School of Engineering, Newcastle University, Cassie Building, Newcastle-upon-Tyne, NE1 7RU

³Centro de Biotecnología y Genómica de Plantas (CBGP, UPM-INIA), Universidad Politécnica de Madrid (UPM), Instituto Nacional de Investigación y Tecnología Agraria y Alimentaria (INIA), Campus de Montegancedo-UPM, 28223 Pozuelo de Alarcón, Madrid, Spain

*Email: angel.goni@upm.es

Bacteria with the ability to transfer electrons are at the core of microbial electrochemical technologies. However, the rational design of such bacteria for the sake of controlling electroactive dynamics has yet to be explored. It has been previously suggested that a spatial redox gradient exists in anode-respiring biofilms^[1]; it has also been demonstrated that it is possible for bacteria to sense their redox environment and respond with differential expression of genes^[2]. We build on this interplay in order to study the fundamental aspects of these complex dynamical systems. We developed a computational model of biofilms targeted at engineering the interactions between redox gradients and discrete cells. The model allows us to explore *in silico* how redox gradients interact with cells engineered with synthetic genetic networks. In particular, we present a model of bistable gene expression coupled to local reduction potential, in which the state of this genetic 'toggle switch' can be made dependent on the cell's position in the biofilm. This shows that genetic networks can be used for engineering control strategies within bioelectrochemical systems, paving the way for new application domains.

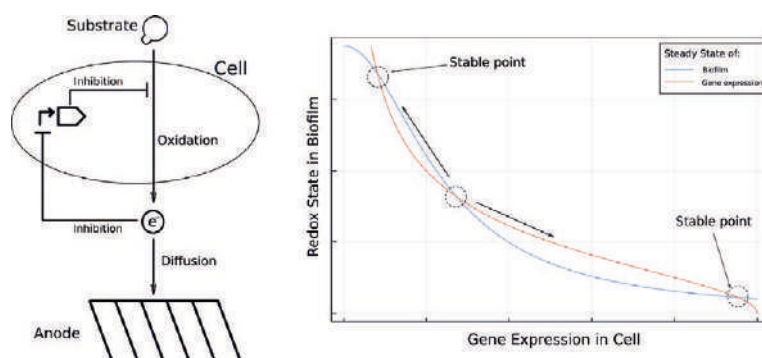

Fig. 1 On the left, a schematic of a hypothetical bistable switch coupling genetic expression and biofilm. Feedback between gene expression and biofilm reduction potential causes the bistability to emerge. On the right, fixed points of this bistable switch are plotted for a simplified model containing just a single cell. The existence and positions of the stable points in this model can then be used to guide exploration of similar behaviour in the more complex model.

Keywords: Computational Modeling, Synthetic Biology, Biofilms, Extracellular electron transport

Funding: Comunidad de Madrid (Atracción de Talento Program, grant

2019-T1/BIO-14053), and Severo Ochoa grant SEV-2016-0672 (2017-2021)

References

[1] Snider R.M. et al. Electron transport in electroactive biofilms. *Proceedings of*

the National Academy of Sciences, Sep 2012, 109: 15467-15472

[2] Tschirhart T et al. Electronic control of gene expression and cell behaviour in *Escherichia coli* through redox signalling. *Nat Commun* 8, 2017, 14030.

Haloalkaliphilic nitrate-reducing electroactive microbial biofilm enriched from the Lonar Lake sediments

Srishti¹, Ramandeep Singh¹, Sukrampal Yadav¹, and Sunil A. Patil^{1*}

¹ Department of Earth and Environmental Sciences, Indian Institute of Science Education and Research Mohali (IISER Mohali), Knowledge City, Sector 81, SAS Nagar, Punjab, India, 140306.

*Email: sunil@iisermohali.ac.in; sunilmicro12@gmail.com

Electrotrophic microorganisms, which can take up electrons from solid-state electron donors to maintain their metabolic processes, have been barely studied from extreme environments [1, 2]. Here, we present nitrate-reducing cathodic microbial biofilm from Lonar Lake sediments, a haloalkaline environment with 9.5pH and up to 24 gNaCl/L salinity [3]. At an applied cathode potential of (vs. Ag/AgCl), the enriched biofilm achieved current density and nitrate reduction efficiency. It reduced nitrate via both partial and complete denitrification processes. The cyclic voltammetry of nitrate-reducing biofilm revealed a redox centre with formal potential of . *Pseudomonas*, *Natronococcus*, and *Pseudoalteromonas* spp. dominated the biofilm at 31.45%, 11.82%, and 9.69% relative sequence abundances, respectively. All these genera are reported for nitrate reduction [4, 5], and only *Pseudomonas* is known for electroactivity. Nitrate-reducing microorganisms produced no soluble redox mediators and did not follow hydrogen-driven nitrate reduction in bioelectrochemical reactors. These observations suggest the direct electron uptake by nitrate-reducing biofilm from cathode. The enriched microorganisms also reduced nitrate using soluble electron donors, such as acetate and citrate, found in lake sediments. This study broadens the ecological niches for electrotrophic microorganisms and suggests their potential role in N-cycling in haloalkaline environments.

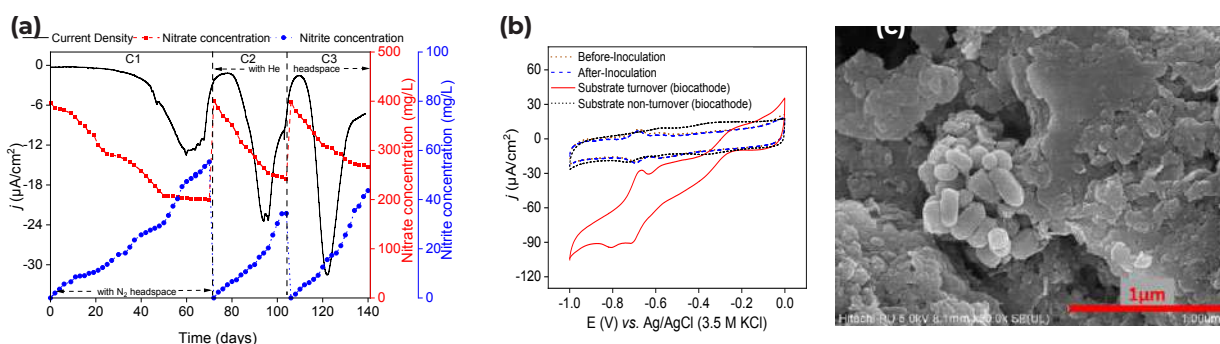

Fig. 1 (a) Chronoamperometry and nitrate/nitrite concentration profiles of the enriched cathodic biofilm. (b) Cyclic voltammograms of the abiotic cathode and biocathode recorded under different conditions. (c) Representative SEM image of the biocathode.

Keywords: Electromicrobiology, Extracellular electron transfer, electrotrophs, haloalkaline environment.

Funding: Science and Engineering Research Board, (Grant no. SRG/2019/000934), IISER Mohali and PMRF from MHRD, Government of India.

References:

[1] Logan BE, et al. Electroactive microorganisms in bioelectrochemical

systems. *Nature Reviews Microbiology*, 2019, 17, 307–319.

[2] Lovley DR, *Electromicrobiology. Annual Review of Microbiology*, 2012, 66, 391–409.

[3] Srishti, et al. Electrochemical enrichment of haloalkaliphilic nitrate-reducing microbial biofilm at the cathode of bioelectrochemical systems, *iScience*, 2021, <https://doi.org/10.1016/j.isci.2021.102682>

[4] Mulla A, et al. Diversity of culturable nitrate-reducing bacteria from the Arabian Sea oxygen minimum zone. *Deep Sea Research Part II: Topical Studies in Oceanography*, 2018, 156, 27–33.

[5] Tindall BJ, et al. *Natronobacterium* gen. nov. and *Natronococcus* gen. nov., Two New Genera of Haloalkaliphilic Archaeobacteria. *Systematic and Applied Microbiology*, 1984, 5 (1), 41–57.

Competition of two highly specialized and efficient acetoclastic electroactive bacteria for acetate in biofilm anode of microbial electrolysis cell

Krishna P. Katuri, Veerraghavulu Sapireddy, Ali Muhammad & Pascal E. Saikaly*

Biological and Environmental Science and Engineering Division, Water Desalination and Reuse Center, King Abdullah University of Science and Technology, Thuwal, 23955-6900, Saudi Arabia

*Email: pascal.saikaly@kaust.edu.sa

Maintaining functional stability of microbial electrolysis cell (MEC) treating wastewater depends on maintaining functional redundancy of efficient electroactive bacteria (EAB) on the anode biofilm. Here, we compare the electrochemical and kinetic properties of two efficient acetoclastic EAB, *Geobacter sulfurreducens* (GS) and *Desulfuromonas acetexigens* (DA), grown as monoculture in MECs fed with acetate. Additionally, we monitor the evolution of DA and GS in co-culture MECs fed with acetate or domestic wastewater using fluorescent in-situ hybridization. The apparent Monod kinetic parameters reveal that DA possesses higher j_{\max} ($10.7 \pm 0.4 \text{ A/m}^2$) and lower $K_{S, \text{app}}$ ($2 \pm 0.15 \text{ mM}$) compared to GS biofilms (j_{\max} : $9.6 \pm 0.2 \text{ A/m}^2$ and $K_{S, \text{app}}$: $2.9 \pm 0.2 \text{ mM}$). Further, more donor electrons are diverted to the anode for respiration in DA compared to GS. In acetate-fed co-culture MECs, DA (98% abundance) outcompete GS for anode-dependent growth. In contrast, both EAB co-exist (DA: $55 \pm 2\%$; GS: $24 \pm 1.1\%$) in wastewater-fed co-culture MECs despite the advantage of DA over GS based on kinetic parameters alone. The co-existence of efficient acetoclastic EAB with high current density in MECs fed with wastewater is significant in the context of functional redundancy to maintain stable performance. Our findings also provide insight to future studies on bioaugmentation of wastewater-fed MECs with efficient EAB to enhance performance.

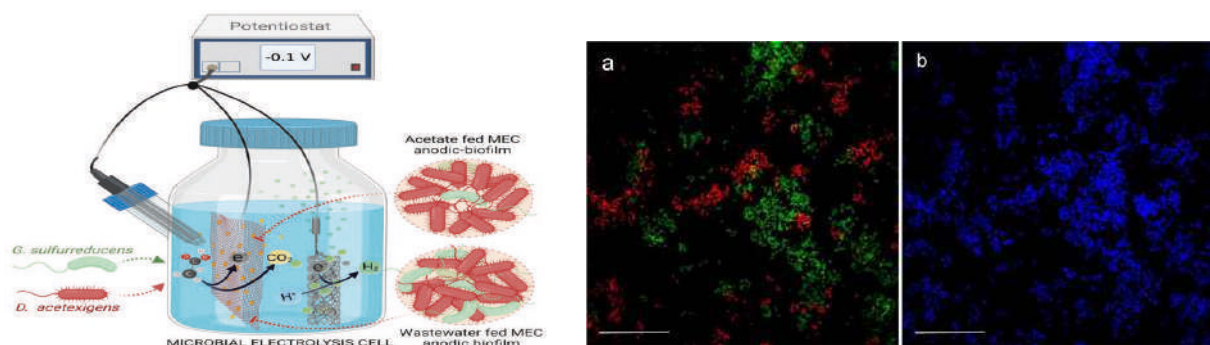

Fig. 1. Cartoon represents the highlights of the work

Fig. 2. CLSM image represent the anodic-biofilm community enriched with sewage. Red - *Geobacter sulfurreducens* & Green - *Desulfuromonas acetexigens*

Keywords: biofilm, electroactive-bacteria, acetoclastic, *Desulfuromonas acetexigens*, *Geobacter sulfurreducens*.

Funding: Center Competitive Funding Program (FCC/1/1971-33-01)

Enhancing power generation and biocompatibility exo-electrogenic bacteria in microbial fuel cell using NiWO₄/rGO as anode electro-catalyst and optimized process parameter

Geetanjali^{1*}, Radha Rani², Sanjay Kumar³, Patit Paban Kundu

¹Chemical Engineering Department, Indian Institute of Technology Roorkee, Roorkee-247667, India

²Department of Biotechnology, Motilal Nehru National Institute of Technology Allahabad, Prayagraj 211004, India

³School of Biochemical Engineering, Indian Institute of Technology (BHU) Varanasi, Varanasi., U.P. 221005 India

*Email: geetanjali.mnnit@gmail.com

Microbial fuel cells (MFCs) are bio electrochemical technologies that are able to treat wastewater and generate electrical energy simultaneously. In this study, NiWO₄ impregnated on graphene oxide sheet (NWG) used as electrocatalyst for anode modification in single chambered MFC (SC-MFC). The properties of synthesized NWG nanocomposite are characterized by FTIR, XRD, EDX, TEM and SEM analysis. NWG modified anodic carbon cloth (CC) as anode is used to improve the performance of SMFC. NWG composite modified CC anode shows capacitance value of 47.27 ± 0.18 F cm⁻² which is 295 times higher than plain carbon cloth. The maximum power density obtained by modified NWG composite CC anode was observed to be 1128 ± 42 mW m⁻². Further, NWG modified anodic CC based SC-MFC is used to improve the efficiency of SC-MFC by statistical optimization of operational parameters. The cumulative effect of enhancing anode electro-catalytic activity and operational parameter optimization in SC-MFC, leads to 8.5 fold higher power density (1458 mW/m²) with respect to unmodified anode and non-optimized process parameters based SC-MFC. In addition, NWG has exposed the maximum abundance of γ -proteobacteria (42.37 %), followed by NiWO₄ and rGO, while CC contained the lowest amount of γ -proteobacteria (11.23 %).

Keywords: Microbial fuel cell, anode electro-catalyst, statistical optimization, microbial community analysis, exo-electrogenic bacteria

References

- [1] Geetanjali, Rani, R., Sharma, D., & Kumar, S. Optimization of operating conditions of miniaturize single chambered microbial fuel cell using NiWO₄/graphene oxide modified anode for performance improvement and microbial communities dynamics. *Bioresource Technology*, 2019, 285(February), 121337.
- [2] Geetanjali, Rani, R., & Kumar, S. Microbial community dynamics of microbial fuel cell in response to NiWO₄/rGO nanocomposites as electrocatalyst and its correlation with electrochemical properties. *Journal of Environmental Chemical Engineering*, 2021, 9(1), 104668. <https://doi.org/10.1016/j.jece.2020.104668>.

The “electro-fermentation effect” of *Geobacter sulfurreducens* co-cultured with *Clostridium pasteurianum* is not induced by electron transfer

María Fernanda Pérez-Bernal¹, Roland Berthomieu¹, Elie Desmond-Le Quémener^{1,*}, Nicolas Bernet¹, Eric Trably¹

¹ INRAE, Univ Montpellier, LBE, 102 avenue des étangs 11100 Narbonne, France

*Email: elie.le-quemener@inrae.fr

Interspecies electron transfer (IET) is a feature of interest in anaerobic ecosystems especially in environments where electron acceptors are lacking. Recent experiments showed that some fermentative organisms can serve as potential electron sinks in such environments. However, the exact mechanism behind this phenomenon remains unclear, especially for fermentative Gram-positive bacteria.

In a previous study^[1], an interaction between the fermentative species *Clostridium pasteurianum* and the model electroactive species *Geobacter sulfurreducens* was demonstrated which resulted in a change of *C. pasteurianum* metabolic pathway on glycerol with an increase of the yield in 1,3-propanediol. The observed shift was attributed to IET, as a similar metabolic shift was observed when *C. pasteurianum* accepted electrons from a cathode. Through new co-culture setups and an RNAseq approach, we unveiled that the metabolic change in cocultures of *C. pasteurianum* and *G. sulfurreducens* is not due to an electron exchange but rather to a cobamide molecule produced by *G. sulfurreducens*, which probably interferes with the key enzyme glycerol dehydratase. Despite the lack of evidence for an electron transfer pathway, cocultures with addition of fumarate still point out to a partial IET. This work shows that *Geobacter* sp. plays a role in some fermentation setups beyond electron transfer.

Keywords: interaction, *Clostridium pasteurianum*, *Geobacter sulfurreducens*, cobamide, interspecies electron transfer

Funding: This work was funded by INRAE grant and CoNaCyT postdoctoral fellowship

References

Moscoviz R, de Fouchécour F, Santa-Catalina G, Bernet N, Trably E. Cooperative growth of *Geobacter sulfurreducens* and *Clostridium pasteurianum* with subsequent metabolic shift in glycerol fermentation. *Sci Rep*, 2017, 7:44334.

Large-scale literature meta-analysis: the impact of the bioelectrochemical process configurations on the electrochemical and wastewater treatment performances

Valentin Larzillière^{1,2*}, Florence de Fouchécour¹, Théodore Bouchez¹, Roman Moscoviz²

¹ Université Paris-Saclay, INRAE, PROSE, 92160, Antony, France

² SUEZ, Centre International de Recherche Sur l'Eau et l'Environnement (CIRSEE), 78230, Le Pecq, France

*Email: valentin.larzilliere@suez.com

Bioelectrochemical systems (BES) represent promising technologies for wastewater treatment at low environmental impact. Since the 2000s, thousands of articles have been published on this topic, exploring a variety of process configurations, electrode materials and effluents, among others. This diversity reflects the momentum of this inter-disciplinary research topic, but also represents a major challenge for identifying the most-promising technological choices for future process scale-up.

This work presents a multivariate analysis made on 4579 observations using the database built according to the methodology developed in *De Fouchécour et al.* A focus was made on two BES performances indicators: COD removal and coulombic efficiency, describing treatment and electrochemical performances respectively.

Among all available observations, 50% reported COD removal above 70%, whereas the median coulombic efficiency was only 20%. This surprisingly low coulombic efficiency raises important questions for the bioelectrochemistry community as it reflects that many research papers report results mostly unrelated to bioelectrochemical reactions.

Thus, the aim of this work is to analyse the influence of process configuration, tCOD, pH and temperature over these process performance indicators. Our results provide key technical information that will hopefully help designing more efficient BES to treat wastewater and facilitate future process scale up.

Overall distribution of COD removal and coulombic efficiency in the scientific literature. The number n represents the number of observations.

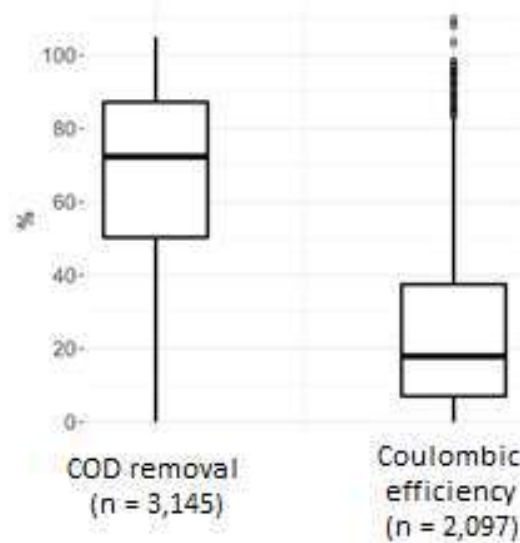

Keywords: wastewater treatment, multivariate-analysis, COD removal, coulombic efficiency

Optimization of filtering anodes for the integration of bioelectrochemical systems into anaerobic membrane bioreactors

Pavaris Viwatthanasittiphong^{1*}, Leon Müller¹, Sven Kerzenmacher¹

¹Center for Environmental Research and Sustainable Technology (UFT), University of Bremen, Leobener Str. 6, Bremen 28359, Germany

*Email: pavaris@uni-bremen.de

Previously, we demonstrated filtering microbial anodes as a promising concept for the integration of bioelectrochemical systems into anaerobic membrane bioreactors operating with brewery wastewater. In particular the so-called hybrid anode, in which polymeric membranes are combined with stainless-steel meshes, has shown a promising potential over porous stainless-steel anodes [1].

To further optimize this concept, we systematically studied a range of stainless-steel meshes with different surface area, wire diameter, and pitch with respect to their electrochemical and filtration performance. Stainless-steel meshes were first tested in non-filtering experiments using *Geobacter Sulfurreducens* in a half-cell setup with an acetate-containing medium to determine the effects of the mesh parameters on current density. Then, the selected meshes are being tested in a crossflow filtration system to observe the medium-term effects on permeate fluxes.

Ongoing experiments show that increasing mesh surface area improves current density but there appears to be saturation. On the other hand, filtration performance is minimally affected in most of the selected meshes except for the one with lowest open filtration area.

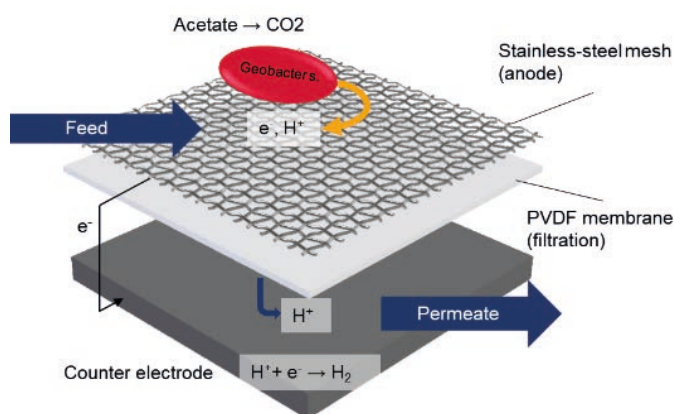

Fig. 1 Hybrid anode concept

Keywords: hybrid anode, filtering anode, anaerobic membrane bioreactor, wastewater treatment

Funding: We are grateful for the financial support from the Bundesministerium für Bildung und Forschung (BMBF) under the programs 031B0365C and 031B1053C.

References

Kocatürk-Schumacher, N. P., Madjarov, J., Viwatthanasittiphong, P., and Kerzenmacher, S. (2018). Toward an Energy Efficient Wastewater Treatment: Combining a Microbial Fuel Cell/Electrolysis Cell Anode With an Anaerobic Membrane Bioreactor. *Frontiers in Energy Research*, 6. <https://doi.org/10.3389/fenrg.2018.00095>

Comprehensive and long-term assessment of critical operational parameters of a pilot MEC for hydrogen production from urban wastewater

Oscar Guerrero-Sodric¹, Juan Antonio Baeza¹, Albert Guisasola¹

GENOCOV: Department d'Enginyeria Química, Biològica i Ambiental, Escola d'Enginyeria, Universitat Autònoma de Barcelona, Cerdanyola del Vallès, Spain

*Email : Oscar.Guerrero@uab.cat

The reported MEC current densities with urban wastewater as a feedstock are low due to its low organic matter content and conductivity. To understand the limiting factors of MEC performance at pilot scale, we present the long-term operation of 150L cassette-type pilot reactor under a wide range of different operational conditions: Voltage applied [0.8-1.1 V], residence time [1.5-5.0 d], organic loading rate [0.05-0.3 g/(L·d)] and temperature [18-30 °C], using two types of feed; raw (100 mg COD₅/L) and amended (1000 mg COD₅/L) urban wastewater (Figures 1 to 2). The reactor was able to produce up to 8.5 L H₂/d with a COD removal efficiency of 60% at optimum conditions. A comprehensive discussion of the benefits and drawbacks of all parameters will be provided in the full presentation. For instance, at different HRT_s the current density was found to be constant and only a significant reduction in COD removal efficiency could be observed. Otherwise, the COD concentration directly affected the current generation and hydrogen production. The process showed a strongly dependence on the temperature and on the applied potential, being 0.9V the optimum value.

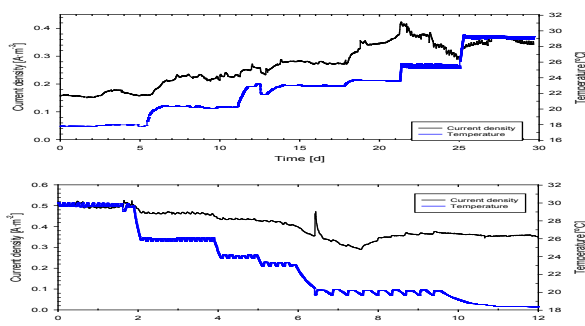

Fig. 1: Current density profile for different temperatures (raw UWW)

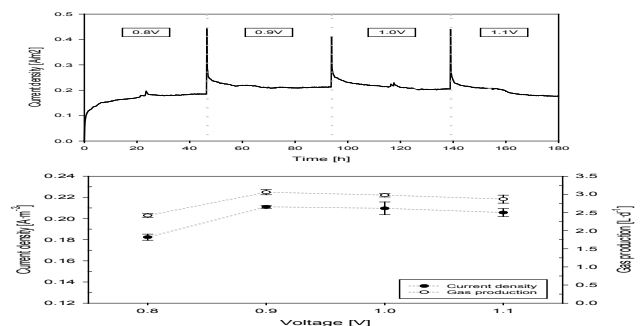

Fig. 2: Current density profile for different voltages (raw UWW)

Keywords: microbial electrolysis cell, waste valorisation, environmental engineering, water technology, bioprocess.

Funding: This work was supported by the European Life programme LIFE19 ENV/ES/000191. The authors are members of the GENOCOV research group (Grup de Recerca Consolidat de la Generalitat de Catalunya, 2017 SGR1175, www.genocov.com)

Exploring avoided environmental impacts and resource recovery from desalination brine through Microbial Desalination Cell treatment

Nastro, Rosa Anna ; Leccisi, Enrica; Toscanesi, Maria; Gengyuan, Liu; Trifuoggi, Marco; Ulgiati, Sergio

EN.TECH Italia srl - Environment & Energy - Naples - Italy; Department of Science and Technology, Parthenope University of Naples; Department of Chemical Sciences, University of Naples Federico II; State Key Joint Laboratory of Environment Simulation and Pollution Control, School of Environment, Beijing Normal University, Beijing, 100875, China; Department of Chemical Sciences, University of Naples Federico II; Department of Science and Technology, Parthenope University of Naples.

In this work, we discuss the results of a lab-scale treatment of desalination brine by means of Microbial Desalination Cells (MDCs) operated with (MDC_3) and without (MDC_2) applied potential (fig.1). Our research took into account energy direct and indirect recovery, organic load removal from wastewater, resource recovery, and environmental impacts minimization.

The treatment in basic MDCs allowed the removal of approximately 33 g of salts (62% of the total) – including chlorides, bromides, and sulfates – from 20 mL of reject brine while the application of a 1.5V external voltage led to a decrease of 63.9% of salts content.

The MDC_2 and MDC_3 used an overall of 7.2J and 7.9J of energy to drive the desalination process, with a COD decrease in the fuel of respectively 77% and 7.6% in comparison to the abiotic control. We quantified the avoided life cycle human and marine eco-toxicity impacts as well as the reduction of the cumulative energy demand of recovered metals.

The main benefit in terms of avoided toxicity would arise from the mercury and copper recovery, while potential economic advantages would derive from the recovered cobalt that represents a strategic resource for many products such as battery storage systems.

Filtrating Microbial Fuel Cells for biofertiliser and energy production

Iwona Gajda^{1*}, Jiseon You¹, Robin Thorn², Neil Willey², John Greenman¹, Darren Reynolds², Ioannis Ieropoulos^{1*}

¹ Bristol BioEnergy Centre, Bristol Robotics Laboratory, University of the West of England, BS16 1QY, UK

² Centre for Research in Biosciences, University of the West of England, BS16 1QY, UK

*Email: iwona.gajda@uwe.ac.uk

MFC processing source-separated urine can enable efficient nutrient recycling, with the additional benefit of nitrogen removal from urine. This work presents the development of urine filtration Microbial Fuel Cells, which synthesise purified catholyte in which key macronutrients such as NPK are recovered, produce energy and remove organic content. In this study, a Filtrating-MFC bioreactors using ceramic based membranes were assembled to oxidise synthetic urine generating electric current, which facilitated the movement of cationic species and water towards the cathode (Fig. 1). As a result, a purified filtrate was achieved at ~6.5 higher rate than the control, while $\geq 90\%$ of organic content was removed. In addition to nitrogen, potassium and phosphorus were also recovered in the cathodic filtrate, thus demonstrating the filtration capacity of the ceramic bioreactors. This work is exploiting pH and ion splitting mechanisms that is directly related to the electric field generated by the system to include target products extraction [1] while recovering water through electroosmosis. The proposed technology allows for the additional oxidation of the organic fraction in urine on the cathode while retaining a high proportion of all other key macro nutrients for potential reuse as a fertiliser. It represents energy-positive approach towards waste valorisation.

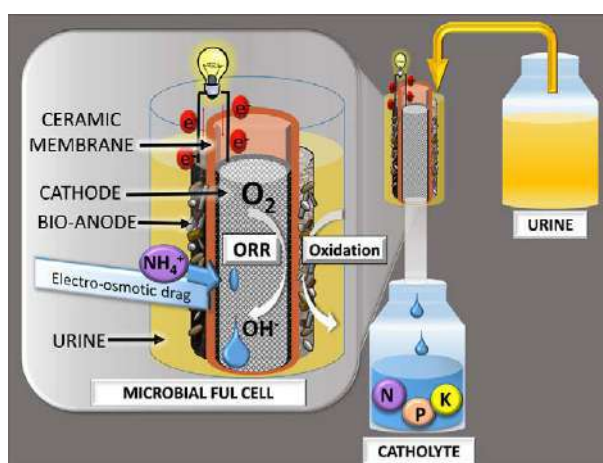

Fig. 1

Filtrating-Microbial Fuel Cell scheme with the catholyte collection system.

Keywords: microbial fuel cell, nutrient recovery, catholyte, electroosmosis, biofertiliser

Funding: Vice Chancellor's Interdisciplinary Research Fund (VC IRCF) and Bill and Melinda Gates Foundation, grant number INV006499.

References

Zeppilli M, Paiano P, Torres C, Pant D. A critical evaluation of the pH split and associated effects in bioelectrochemical processes. *Chem Eng J* 2021;422:130155

How can microbial heat help in optimising the energy conversion of Microbial Electrochemical Systems (MES)?

Pavlina Theodosiou^{1,*} and Elizabeth Heidrich¹

¹ Newcastle University, School of Engineering, Cassie Building, Newcastle upon Tyne, NE1 7RU

*Email: pavlina.theodosiou@newcastle.ac.uk

Microbial Electrochemical Systems (MESs) utilise microbes as biocatalysts for transforming waste and other organics into resources, i.e., electricity, hydrogen, or chemical compounds. MESs have entered the pilot-scale realm in wastewater treatment plants [1] and off-grid locations [2]. Hence, they have attracted interest as a feasible, sustainable, and environmentally friendly technology. However, the performance of pilot-scale studies (100-1000L) is 1-3 order of magnitude lower than the lab scale (0.1-0.2L) ones. These disparities hinder the technology from full deployment and weaken industry confidence. Efforts to address this disparity and improve MES efficiencies have been heavily focused on the MES materials rather than the inherently complex biology of the system. Observing pilot-scale MES behaviour reveals that these systems are resilient in temperature fluctuations - even at 10°C - as opposed to anaerobic digestors, which also use anaerobic bacteria but struggle at temperatures below 20 °C. Hence, this suggests that the heat energy produced during bioconversion of chemical energy to electrical energy is a vital energy vector that has not been yet accounted for. Through the BIOHEAT project, we are investigating the heat energy transfers in electroactive microbial systems. Linking heat energy to growth will offer a deeper understanding of anaerobic systems' biology.

Keywords: microbial electrochemical systems, MES, microbial heat, pilot-scale, heat energy

Funding: This work is funded by EPSRC (Grant No. EP/S032517/1)

References

[1] Elizabeth S. Heidrich, Stephen R. Edwards, Jan Dolfing, Sarah E. Cotterill, Thomas P. Curtis (2014) Performance of a pilot scale microbial electrolysis cell fed on domestic wastewater at ambient temperatures for a 12month period, *Bioresource Technology*, 173, 87-95.

[2] Walter, X.A.; Merino-Jiménez, I.; Greenman, J.; Ieropoulos, I. PEE POWER® urinal II – Urinal scale-up with microbial fuel cell scale down for improved lighting. *J. Power Sources* 2018, 392, 150–158.

Bacteria coated cathodes as an in-situ hydrogen evolving platform for Microbial Electrosynthesis

Elisabet Perona-Vico^{1,*}, Laura Feliu-Paradedà¹, Sebastià Puig², Lluís Bañeras¹

¹ Molecular Microbial Ecology Group, Institute of Aquatic Ecology (University of Girona), Maria Aurèlia Capmany 40, 17003 Girona, Spain

² LEQUiA, Institute of the Environment (University of Girona), Maria Aurèlia Capmany 69, 17003 Girona, Spain

*Email: elisabet.perona@udg.edu

Hydrogen is a key intermediate in microbial electrosynthesis as a mediator of the reduction of carbon dioxide (CO₂) into added value compounds. In the present work we aimed at studying the biological production of hydrogen in biocathodes operated at -1.0 V vs. Ag/AgCl, using a highly comparable technology and CO₂ as the sole carbon feedstock. Ten bacterial strains were chosen from genera *Rhodobacter*, *Rhodopseudomonas*, *Rhodocyclus*, *Desulfovibrio* and *Sporomusa*, all described as hydrogen producing candidates. Monospecific biofilms were formed on carbon cloth cathodes and hydrogen evolution was constantly monitored using a microsensor. Eight over ten bacteria strains showed electroactivity and H₂ production rates increased significantly (2 to 8-fold) compared to abiotic conditions for two of them (*Desulfovibrio paquesii* and *Desulfovibrio desulfuricans*). *D. paquesii* DSM 16681 exhibited the highest production rate (45.6 ± 18.8 μM·min⁻¹) compared to abiotic conditions (5.5 ± 0.6 μM·min⁻¹), although specific production rates (per unit biomass) were like those obtained for other strains. This study demonstrated that many microorganisms are suspected to participate in net hydrogen production but inherent differences among strains do occur, which are relevant for future developments of resilient biofilm coated cathodes as a stable hydrogen production platform in microbial electrosynthesis.

Keywords: electroactive bacteria, electrochemistry, electromicrobiology, hydrogen, pure cultures.

Funding: European Union's Horizon 2020 (No. 760431)

La última batalla: Interaction between *Geobacter* spp. dominated biofilms and anaerobic digestion effluents

Daniel Dzofou Ngoumelah^{1,2*}, Falk Harnisch², Jörg Kretzschmar^{1*}

¹DBFZ - Deutsches Biomasseforschungszentrum gemeinnützige GmbH (German Biomass Research Centre), Torgauer Straße 116, 04347 Leipzig

² Department of Environmental Microbiology, UFZ – Helmholtz-Centre for Environmental Research, Leipzig, Germany

Email: Daniel.Dzofou.Ngoumelah@dbfz.de ; Joerg.Kretzschmar@dbfz.de

Anaerobic digestion (AD) and microbial electrochemical technologies (MET) can be combined in manifold ways, e.g., for removal of monovalent ions, effluent polishing, electrochemical biogas upgrading and sensor applications [1]. However, recent studies showed negative influences of AD effluents on the performance of pre-grown *Geobacter* spp. dominated biofilms [2]. Therefore, the questions arose, if *Geobacter* spp. dominated biofilms can be adapted to AD environments and, if the biofilm age as well as the presence or activity of methanogens affects the biofilm stability?

To answer these questions, we performed several shock and adaptation experiments using AD effluents in different concentrations (0% - 100%) and biofilms of different age. The activity of methanogens was inhibited by application of 50 mmol L⁻¹ 2-BES, their presence was minimized by filtration of the AD effluent (0.2 µm pore size).

Old biofilms (pre-grown for 5 weeks) showed higher resistance and activity during shock experiments with AD effluents compared to young biofilms (3 weeks). Adaption of biofilms failed for a yet unknown reason, whereas the application of 2-BES as well as filtration of the AD effluent had positive effects on the activity and resistance of 5 weeks pre-grown biofilms [3].

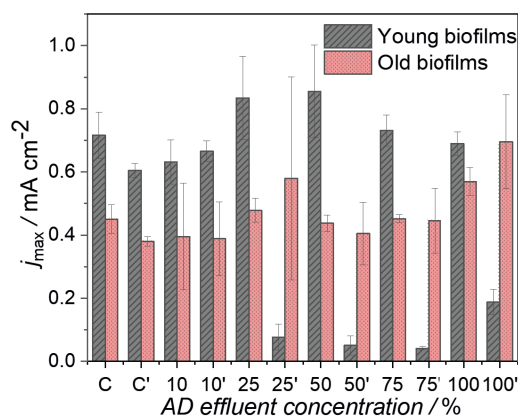

Fig.1: Maximal current density (j_{max}) during shock of young and old biofilms with increasing AD concentrations, C: control with only acetate as carbon source, ' indicates second week (second batch), n = 3, error bars indicate CI.

Keywords: bioelectrochemical systems, longevity, resistance, alternative electron acceptors

Funding: D.D.N. greatly acknowledges funding by the PhD student programm of the German academic exchange service (DAAD under the grant number: 91692428)

References

- [1] J. De Vrieze, J.B.E. Arends, K. Verbeeck, S. Gyldemin, K. Rabaey, Water Res. 2018, 146, 244-255
- [2] J. Kretzschmar, P. Böhme, J. Liebetrau, M. Mertig, F. Harnisch, Chem. Eng. Technol. 2018, 41 (4), 687-695
- [3] D. Dzofou Ngoumelah, F. Harnisch, J. Kretzschmar, Environ. Sci. Technol. Accepted

Selection and enrichment of electroactive microbial communities for removal of pharmaceuticals in microbial electrochemical systems

Razieh Rafieenia^{1*}, Mira Sulonen¹, Amelia McCollom¹, Mohamed Mahmoud², Fatma El-Gohary² and Claudio Avignone Rossa¹

¹ Department of Microbial Sciences, University of Surrey, Guildford GU2 7XH, United Kingdom

² Water Pollution Research Department, National Research Centre, Cairo, Egypt

*Email r.rafieenia@surrey.ac.uk

Microbial Electrochemical Systems (MESs) represent an environmentally friendly approach for wastewater treatment, where the degradation of organic matter is accompanied by simultaneous production of value-added products and/or energy. Some pharmaceuticals and other bioactive compounds are amongst the recalcitrant contaminants of highest concern, as they are continuously released into the environment and aquatic environments from discharges from pharmaceutical industries, animal farms, hospital effluents, and domestic wastewater, despite their harmful activity against living organisms. In the present study, we studied the acclimation of electroactive microbial communities to be used in the removal of three pharmaceuticals found in waters (carbamazepine, atenolol, and ketoprofen).

MESs were inoculated with anaerobic digestion sludge and subjected to receiving pharmaceuticals in the medium (500 µg/L). Maximum current densities of 215.64, 272.01 and 465.46 mA/m² were obtained for the MESs receiving atenolol, carbamazepine and ketoprofen, respectively. Microbial community analysis revealed the abundant microbial species on anodic biofilm of MFCs.

The microbial communities enriched in MESs will be used as inocula in a system called Intimate Coupling of Photocatalysis and Biodegradation (ICPB-MES) which combines the capacity of microbial communities in MES to degrade recalcitrant compounds with another chemical approach (photocatalysis) to increase the pharmaceuticals removal efficiency.

Keywords: Microbial electrochemical systems, Recalcitrant compounds, Pharmaceuticals, Microbial communities, biodegradation

Funding: This project is an Institutional Link Project collaboration with the National Research Centre (Egypt), supported by the British Council / Newton-Mosharafa Fund (Grant 352368074).

Effect of hydraulic conditions in PFR reactors using bio-electrochemical processes to influence greenhouse gas emission

Annegret Budach^{1*}, Giusi Favoino¹, Jochen A. Müller^{1,2}, Anja Miltner¹, Matthias Kästner¹

¹ Helmholtz Centre for Environmental Research, Department of Environmental Biotechnology, 04315 Leipzig

² Karlsruhe Institute of Technology, Institute for Biological Interfaces 76131 Karlsruhe

*Email: annegret.budach@ufz.de

Constructed wetlands (CWs) are an alternative to conventional wastewater treatment. However, for broader application, their performance, in particular with respect to greenhouse gas emission^[1,2] (e.g. CH₄) has to be optimized. Planted fixed bed laboratory scale reactors (PFR) with electroconductive materials (biochar, graphite coke) were used for enhancement of the microbial electron acceptor availability in CWs for improved the electron flux and overall elimination performance^[3]. In addition, the abundance and activity of methanogenic bacteria was analyzed.

Three PFR reactors filled with either gravel (= control), graphite coke, or biochar were operated at stable inflow conditions while varying internal recirculation flows. The electrochemical properties were measured via cyclic voltammetry (-1.0 V vs SHE, 10 mV/min). Increasing recirculation decreased the oxidation peaks in the cyclovoltammograms, indicating higher biofilm activities and relate gradients to mass transfer limitations. To assess the effect of the electroconductive materials on methane formation, the abundances of methanogenic species in water and filter-bed samples were quantified by qPCR. The relative abundance of methanogenic species declined from 81% in gravel to 24% in the biochar and 26% in the graphite coke reactor.

The results will provide information on how optimization of the hydraulic conditions superimposes the effects of electrically conductive materials.

Keywords: Bio-electrochemistry, WW treatment, greenhouse gases

Funding: ELECTRA Horizon 2020 funded by EC and NSFC (GA 826244)

References

- [1] Chen D., Wang C., Shen J., Li Y., Wu J., Response of CH₄ emissions to straw and biochar applications in double-rice cropping systems: Insights from observations and modeling. *Environ. Pollut.*, 2018, 95–103
- [2] Søvik A. K., Kløve B., Emission of N₂O and CH₄ from a constructed wetland in southeastern Norway. *Science of The Total Environment*, 2007, 380: 28-37
- [3] Prado, A. et al., Electroactive biochar outperforms highly conductive carbon materials for biodegrading pollutants by enhancing microbial extracellular electron transfer. *Carbon*, 2019, 146

Ammonia recovery from digestates in a three-chambered bioelectrochemical system through hydrophobic membranes

M. Cerrillo¹, L. Burgos¹, V. Riau¹, J. Noguerol¹, A. Bonmatí^{1*}

¹ GIRO, Institute of Agrifood Research and Technology (IRTA), Torre Marimon, E-08140 Caldes de Montbui, Barcelona (Spain)

*Email: august.bonmati@irta.cat

A three-chambered microbial electrolysis cell (MEC) (600 mL each compartment) was equipped with a cation exchange membrane (CEM) between the anode and the cathode compartment; and a polytetrafluorethylene (PTFE) membrane (0.45 µm pore size), between the cathode and the ammonia recovery compartment (Fig. 1). The MEC was operated in continuous mode for 115 days, feeding the anode compartment with digested pig slurry and the cathode compartment with a 0.1 g NaCl L⁻¹ solution.

The MEC achieved an average ammonium removal efficiency in the anode compartment of 23%±1. The evolution of the cathode bulk solution pH (10.8±1.5) was favourable to the displacement of the ammonium-ammonia equilibrium towards the second species, and allowed a maximum flux through the hydrophobic membrane of 2.74 g N m⁻² h⁻¹. The transferred ammonia was recovered in the third compartment by absorption in H₂SO₄ (1.8 M) and represented around 25% of the ammonia migrated from the anode to the cathode compartment.

The MEC combined with hydrophobic membranes reveals as an interesting technology for the treatment of high strength wastewater such as livestock manure. Compared to a stripping and absorption system [1], the use of hydrophobic membranes for ammonia recovery avoids electricity consumption for air pumping.



Fig. 1 Picture of the three compartment MEC. Anode, cathode and ammonia recovery chambers on the left, centre and right compartments, respectively.

Keywords: Microbial Electrolysis Cell, hydrophobic membrane, ammonia recovery, digestate.

Funding: Spanish Ministry of Economy and Competitiveness (INIA project RTA2015-00079-C02-01). CERCA Program and the Consolidated Research Group TERRA (ref. 2017 SGR 1290), both from the Generalitat de Catalunya.

References

Cerrillo M, Viñas M, Bonmatí A. Overcoming organic and nitrogen overload in thermophilic anaerobic digestion of pig slurry by coupling a microbial electrolysis cell. *Bioresource Technology*, 2016, 216, 362: 372.

Simulation of Pilot Scale Microbial Electrochemical Technologies

Jordan R. Day^{1*}, Elizabeth S. Heidrich¹, Toby S. Wood²

¹ Newcastle University School of Engineering NE1 7RU

² Newcastle University School of Mathematics, Statistics and Physics NE1 7RU

*Email: J.R.Day1@newcastle.ac.uk

Microbial electrochemical technologies (METs) have the potential to reduce energy usage and requirements in the wastewater treatment process. However, these reactors need further refinement before implementation into the treatment process. Due to high financial cost and time requirements to develop pilot scale systems, design and optimisation process can be heavily hindered[1]. Mathematical modelling can reduce the cost and time required to design complex systems, and is being increasingly used in METs. Modelling METs for real life applications including resource recovery and wastewater treatment represents a significant challenge. To be of value, models must be complex enough to reproduce important behaviour of MET, yet simple enough to provide insight into underlying causes of this behaviour. Ideally, models must also be scalable to future industrial applications, rather than limited to describing existing laboratory experiments. We present a scalable model simulating both fluid flow and bioelectrochemical processes in MET, benchmarking against experimental pilot-scale bioreactor [2]. The model describes substrate transport through a two-dimensional fluid domain, and biofilm growth on anode surfaces. Electron transfer is achieved by an intracellular redox mediator. Finding significant spatial variations in both substrate concentration and current density. Simple changes to the reactor layout can greatly improve the overall efficiency.

Fig. 1 Graphical Summary of fluid and substrate transportation through reactor domain alongside simulation results.

Keywords: Mathematical Modelling, Computational Fluid Dynamics, Microbial Electrochemical technologies, Pilot-scale, Wastewater Treatment

Funding: EPSRC [EP/R51309X/1](#)

References

[1] Aiken D.C, Curtis, T. P, Heidrich, E. S. Avenues to the financial viability of microbial electrolysis cells [MEC] for domestic wastewater treatment and hydrogen production. *Int. J. Hydrogen Energy*, 2019, 44, 2426-2434.

[2] Leicester D, et al. Optimising the hydraulic retention time in a pilot-scale microbial electrolysis cell to achieve high volumetric treatment rates using concentrated domestic wastewater. *Molecules*, 2020 25, 2945.

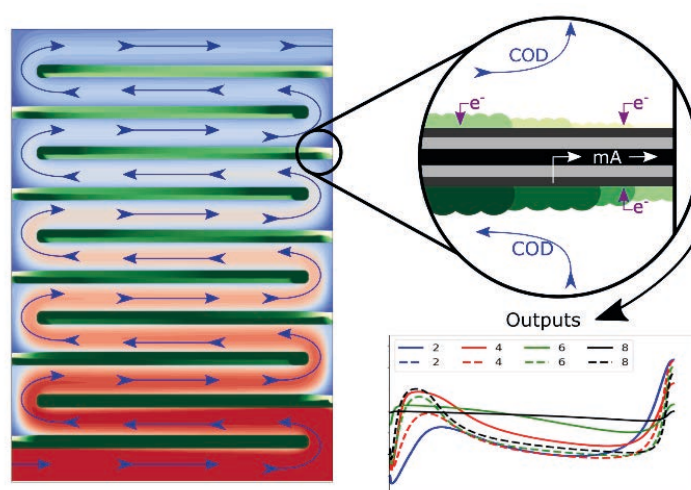

Low energy consuming bioelectrochemical system for ammonium recovery from wastewater as liquid fertilizer

Eduard Borràs*, Martí Aliaguilla, Diana Losantos, Sonia Sanchis, Pau Bosch-Jimenez, Daniele Molognoni

¹ LEITAT Technological Center, C/ de la Innovació 2, 08225 Terrassa, Spain

*Email: eborras@leitat.org

Bioelectrochemical systems (BES) have emerged as a potential technology for nitrogen removal and recovery from wastewaters with low energy consumption. In the Run4life Project, a reactor to produce a liquid fertilizer from wastewater at low energy consumption has been developed. This consisted of a multi-chamber flat plate reactor connected to an air stripping system to recover ammonium from wastewater as ammonium nitrate in an acid trap filled with HNO_3 (0.1M). The BES system was tested under different electrochemical conditions working with synthetic wastewater. Applying an external voltage of +0.2 V and an air flow rate (for N stripping) of $150 \text{ mL} \cdot \text{min}^{-1}$ proved to be the best scenario for ammonium recovery, in which $15.8 \pm 1.6 \text{ g N-NH}_4^+ \cdot \text{m}^{-2} \cdot \text{d}^{-1}$ were removed from wastewater (corresponding to $75.1 \pm 3.8\%$ of its original content) and $9.6 \pm 1.9 \text{ g N-NH}_4^+ \cdot \text{m}^{-2} \cdot \text{d}^{-1}$ were recovered ($45.3 \pm 7.5\%$) at a current density of $2.5 \pm 0.2 \text{ A} \cdot \text{m}^{-2}$. The power consumption of the process (without considering aeration) was of 1.6 kWh per kg of removed nitrogen, which was lower than similar experiences reported in literature, making the proposed system appealing. Finally, tests with real blackwater as analyte were performed.

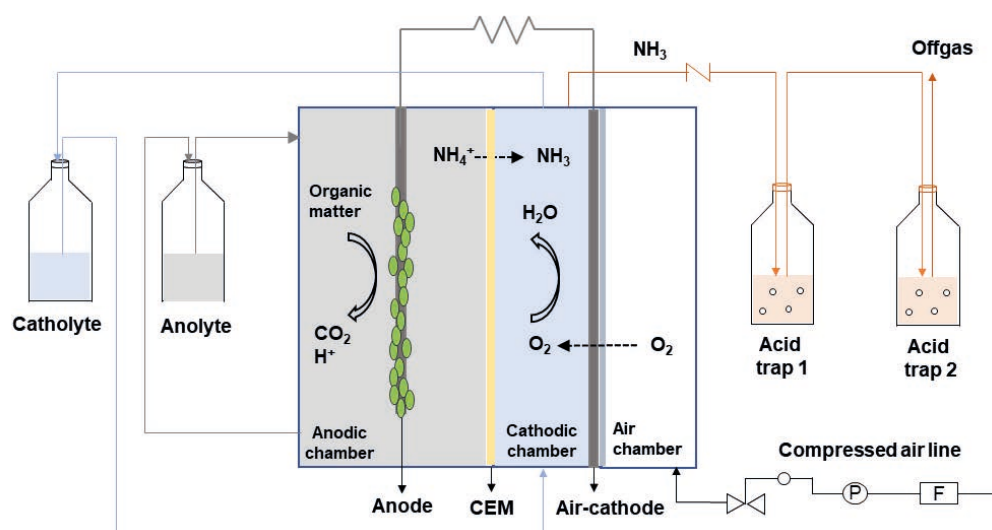

Figure 1. Experimental setup scheme used for nitrogen recovery in Run4life project.

Keywords: blackwater; electroactive bacteria; microbial electrolysis cells; nitrogen recovery.

Funding: This project has received funding from European Union's Horizon 2020 research and innovation programme under Grant Agreement no. 730285 ([Run4life](#)).

Bioelectrochemical dechlorination of 1,2-dichloropropane by a *Dehalogenimonas*-enriched culture

David Fernández-Verdejo¹, Ernest Marco-Urrea¹, Paqui Blánquez¹, Pilar Cortés², Albert Guisasola^{3,*}

¹ Biorem UAB, Department of Chemical, Biological and Environmental Engineering, School of Engineering, Universitat Autònoma de Barcelona, Bellaterra, Barcelona, Spain, 08193

² Departament de Genètica i de Microbiologia, Universitat Autònoma de Barcelona, Barcelona, Spain, 08193

³ GENOCOV, Department of Chemical, Biological and Environmental Engineering, School of Engineering, Universitat Autònoma de Barcelona, Bellaterra, Barcelona, Spain, 08193.

*Email: albert.guisasola@uab.cat

1,2-Dichloropropane is a contaminant which can be found in groundwater sources. In this study, we successfully degraded, for the first time, concentrations up to 1000 µM of 1,2-dichloropropane to propene using a mixed culture containing the anaerobic dehalorespiring species *Dehalogenimonas alkenigignens* [1] using a bioelectrochemical system, consisting in two independent vessels separated by a cationic exchange membrane. The 1,2-dichloropropane was reduced at the cathode of the system due to the capability of bioelectrochemical systems of providing a continuous supply of hydrogen. This results in a promising strategy in view of sustaining the long-term growth of hydrogen-dependent dehalogenating bacteria [2]. Therefore, this work studies the effect of this continuous hydrogen supply in the dechlorination rate and in *Dehalogenimonas* biomass concentration. Low cellular density is the major bottleneck when applying these systems to real environments and, thus, the achievement of high biomass concentrations would be a breakthrough for the remediation of polluted aquifers. The biomass growth was measured by qPCR and was compared to those obtained in conventional suspended cultures. A graphite brush was used in the cathode due to its high adsorption capabilities in order to maximise biomass attachment. The full presentation will also show a comprehensive study on the effect of the operational conditions (e.g. different applied cathode potentials) on the dechlorination rates obtained.

Keywords: bioelectrochemical reduction, *Dehalogenimonas*, 1,2-dichloropropane, bioremediation, dehalogenation

Funding: This work has been funded by the Spanish Ministry of Science, Innovation and Universities project CTM2017-91879-EXP.

References

- [1] Martín-González L, et al. Stable Carbon Isotope Fractionation During 1,2-Dichloropropane-to-Propene Transformation by an Enrichment Culture Containing *Dehalogenimonas* Strains and a *dcpA* Gene. *Environmental Science & Technology*, 2015, 49 (14): 8666.
- [2] Leitão P, et al. Bioelectrochemical Dechlorination of 1,2-DCA with an AQDS-Functionalized Cathode Serving as Electron Donor. *Fuel Cells*, 2017, 17: 612.

Electrobioremediation of Pharma pollutants is boosted in a Microbial Electrochemical Fluidized Bed Reactor

Yeray Asensio^{1*}, Alejandro Sánchez-Gómez¹, María Llorente¹, Carlos Manchón¹, Karina Boltes¹, Abraham Esteve-Núñez^{1,2}

¹ University of Alcalá, Plaza de San Diego, s/n, 28801, Alcalá de Henares (Madrid).

²IMDEA WATER, Avda Punto COM, 2, 28805, Alcalá de Henares (Madrid)

*Email: yeray.asensio@uah.es

Wastewater produced in pharmaceutical manufacturing are characterized by high concentrations of Total Organic Carbon (TOC) and the presence of pollutants that eventually will be considered as emerging contaminants (EC) once they are discharged to urban wastewater [1].

In this work, we have explored the removal of carbamazepine (CBZ), and sulfamethoxazole (SMX) from pharma wastewater in Microbial Electrochemical Fluidized Bed Reactors (ME-FBR). Different anode potentials applied to the fluid-like anode, varying from -200 mV to +600 mV (vs. Ag/AgCl), were evaluated to optimize and boost the pharma pollutant removal during the semi-continuous operation of the ME-FBR [2,3].

Results showed that adsorption phenomena or abiotic electrochemical removal were significantly lower than the electrobioremediation capacity exhibited by microorganism grown at ME-FBRs. Indeed, ME-FBR showed a remarkable capacity for removing pharma pollutants at +200 mV (vs. Ag/AgCl) anode potentials (81.45% TOC, 87.9% CBZ and 84.5% SMX removal at). It outperformed an UASB reactor, operated as control. Finally, the ecotoxicity of the treated effluent was assayed with *Vibrio fischeri*. Detoxifications of up to 70% were found at +200 and +400 mV, revealing the technological potential of ME-FBR for treating those highly polluted wastewaters.

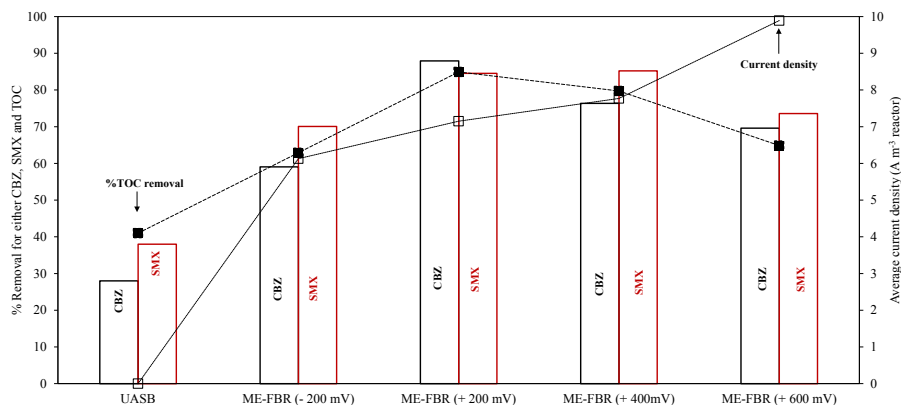

Fig.1. CBZ and SMX removal in ME-FBR at different anode potentials. Comparison with a UASB reactor

Keywords: pharma wastewater, microbial electrochemical fluidized bed reactors, carbamazepine, sulfamethoxazole, detoxification, ME-FBR

Funding: This research was supported by the Spanish Ministry of Science, Innova-

tion and Universities, through the project MET-FLUID (RTI2018-101974-B-C21)

References

[1] Pun, A, et al. Detoxification of wastewater containing pharmaceuticals using horizontal flow bioelectrochemical filter. *Bioresource Technology Reports*, 2019,7:100296.

[2] Asensio, Y, et al. Upgrading fluidized

bed bioelectrochemical reactors for treating brewery wastewater by using a fluid-like electrode. *Chemical Engineering Journal*, 2021, 406:127103.

[3] Tejedor, S, et al. Merging microbial Electrochemical systems with electrocoagulation pretreatment for achieving a complete treatment of brewery wastewater. 2017, 330 (1068-1074).

Development of a four-chamber microbial desalination cell for simultaneous treatment of Cr (VI) containing wastewater and by-products recovery

Md Tabish Noori^{1,2*}, Juan Manuel Ortíz², Abraham Esteve Nunez^{1,2}

¹ Department of Chemical Engineering, University of Alcala, Alcala De Henares, Spain – 28805

² IMDEA Aqua, Alcala De Henares, Spain – 28805

*Email: md.noori@uah.es

Here, we developed a novel four-chamber microbial desalination cell with different ion exchange membranes to treat Cr (VI) (2 mM) containing wastewater and by-product recovery (Fig. 1). We inoculated cathode and anode chamber with *Geobacter sulfurreducens* and the cathode was polarized at -0.8 V (vs. Ag/AgCl). Simulated wastewater containing soluble bicarbonate as carbon source and Cr (VI) (1 and 2 mM) with nutrients was added to the cathode chamber. Moreover, anode was fed with regular acetate-based substrate (2 g/l). We noted almost 100 % Cr (VI) removal in cathode in i) 24 h with a coulombic efficiency of 9.3 % when initial concentration of Cr (VI) was 1 mM; and b) 72 h with a coulombic efficiency of 13.9 %, when concentration increased to 2 mM. When acetate (2 g/l) was added to the anodic substrate, Cr (VI) reduction rate decreased significantly to 96 h (1mM) and 168 h (2mM). The pH in the acid and base recovery chambers were noted to be ≈ 2 and ≈ 12.5 , respectively thus confirming a four-chamber MDC with *G. sulfurreducens* could be useful to remove high concentration of Cr (VI) from wastewater including organics removal and by-products recovery.

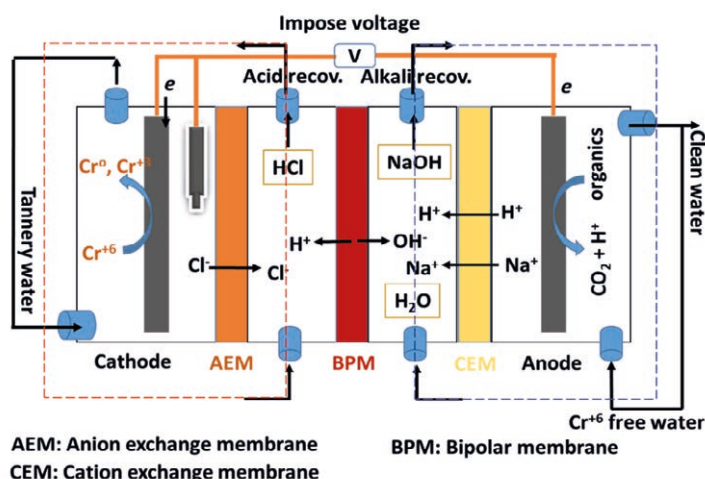

Figure1: Schematic diagram of four-chamber MES with working mechanism.

Keywords: biocathode, *Geobacter sulfurreducens*, hexavalent Chromium, microbial desalination cell.

Funding: This project has received funding from European Union's Horizon 2020 research and innovation program under Marie Skłodowska grant agreement No. 754382

Desalination of Brackish Water Using a Microbial Desalination Cell: analysis of the electrochemical behaviour

Marina Ramirez-Moreno^{1,2*}, Abraham Esteve-Núñez^{1,2} and Juan Manuel Ortiz¹

¹IMDEA Water Institute, Av. Punto Com, 2, 28805 Alcalá de Henares, Madrid, Spain

²Department of Analytical Chemistry, Physical Chemistry, and Chemical Engineering Department, Universidad de Alcalá, 28871, Alcalá de Henares, Madrid, Spain

*Email: marina.ramirez@imdea.org

A microbial desalination cell (MDC) is a microbial fuel cell (MFC) integrated with an electro dialysis (ED) cell in the same device to simultaneously treat wastewater, desalinate brackish or seawater, and produce electric energy [1]. Most previously reported studies used oxygen reduction as the primary cathodic reaction [2]. In contrast, we have explored brackish water desalination (7 g L^{-1}) and energy production using a laboratory MDC system (cross-section 100 cm^2 , batch mode) and ferricyanide as the catholyte. Furthermore, a rational explanation of desalination performance when using a catholyte is presented, and, additionally, the impact of producing electrical energy on desalination performance is discussed [3]. Interestingly, conductivity variation in the saline chamber can be used to predict electrochemical performance. In summary, this study provides the basis for the development, design, and optimisation of low-energy desalination using MDC technology.

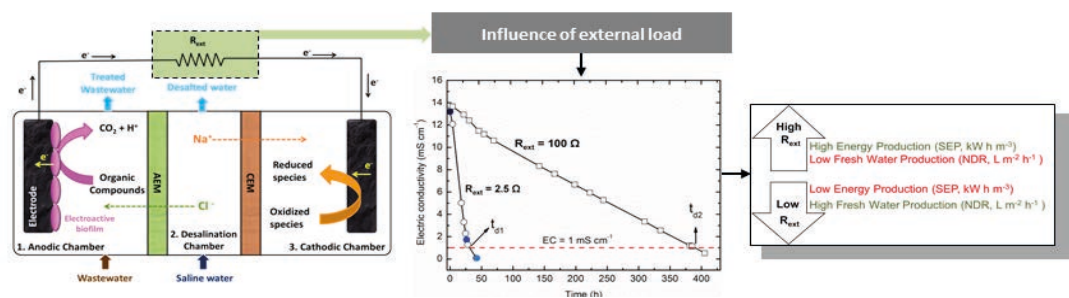

Fig. 1. Left: Scheme of an MDC. Right: Electrical conductivity versus time for an MDC desalination cycle (7 g L^{-1} / 13 mS cm^{-1}) with 2.5Ω (circles) and 100Ω (squares).

Keywords: microbial desalination cell, brackish water, electrochemistry, freshwater production.

Funding: Project "MIDES – H2020" has received funding from the European Union's Horizon 2020 research and innovation programme (N°

685793). Juan M. Ortiz acknowledges the financial support of Agencia Estatal de Investigación (AEI) and Fondo Europeo de Desarrollo Regional (FEDER) (Proyecto BioDES, CTM2015-74695-JIN).

References.

- [1] Cao, X., et al., A New Method for Water Desalination Using Microbial Desalination Cells. *Environmental Science & Technology*, 2009. 43(18): p. 7148-7152.
- [2] M. Ramírez-Moreno, P. Rodenas, M. Aliaguilla, P. Bosch-Jimenez, E.

Borràs, P. Zamora, V. Monsalvo, F. Rogalla, J.M. Ortiz, A. Esteve-Núñez, Comparative Performance of Microbial Desalination Cells Using Air Diffusion and Liquid Cathode Reactions: Study of the Salt Removal and Desalination Efficiency, *Front. Energy Res.* 7 (2019) 135.

- [3] M. Ramírez-Moreno, A. Esteve-Núñez and J.M. Ortiz, Desalination of Brackish Water Using a Microbial Desalination Cell: analysis of the electrochemical behaviour, *Electrochimica Acta*, 388 (2021) 138570.

Electrobioremediation by METland® solution differentiates among enantiomers in mixtures of pharmaceuticals and herbicides

Álvaro Pun^{1*}, Abraham Esteve^{1,2}, Karina Boltes^{1†}

Universidad de Alcalá, Plaza San Diego s/n, Alcalá de Henares, 28801 Madrid (Spain)

² IMDEA Agua, Alcalá de Henares, Spain, 28805

*Email: alvaro.pun@uah.es

Removal of emerging contaminants (EC) is a growing concern of wastewater treatments. Microbial electrochemical technologies (MET) implemented into biofilters (METland® solution) are capable to treat both conventional pollutants and EC by improving the electrons flows across the microbial community [1,2]. Furthermore, chirality is an essential property of chemicals in interactions with biological systems, often overlooked in contaminants [3].

Here, two vertical upflow METland® and two conventional upflow electrode-free biofilters, were fed with different cocktails of chiral pollutants. One toxic wastewater contained six drugs of different pharmacological actions (one antidepressants, three beta-blockers, one antihypertensive and one bronchodilator) and the other contained six phenoxyacids herbicides.

Biofilters were operated at 1 day HRT for 3 months and effluents were analysed by Electrophoresis using a HP 3DCE system to calculate the enantiomeric rate of every chemical. The toxic wastewater with six chiral drugs in racemic mixture showed no differences in enantiomer fate between METland® and electrode-free control. By contrast, the wastewater with six chiral phenoxyacids herbicides showed differences in a 5-fold range for enantiomer composition after METland® treatment in comparison with electrode-free biofilter. Wastewater toxicity for microalgae aligns with this, showing no changes after METland® for drugs but a decrease for fenoxycids.

Fig. 1 Enantiomeric Fraction changes of Phenoxy acids during the experiment (A: conventional; B: METland®)

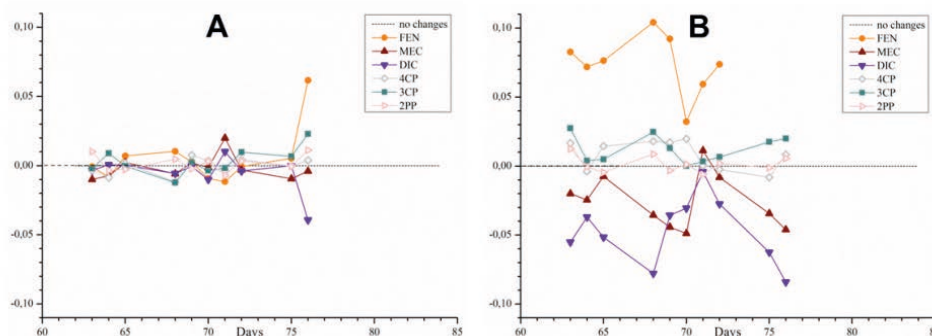

Keywords: Microbial Electrochemical Technology, Emerging Contaminants, Biofilter, Pharmaceuticals, Enantiomers

References

[1] Wang X, et al. Microbial electro-

chemistry for bioremediation. Environmental Science and Ecotechnology. Vol 1 January 2020, 100013

[2] Pun A, et al. Detoxification of wastewater containing pharmaceuticals using horizontal flow bioelectrochemical filter. Bio-

resource Technology Reports 7 (2019) 100296

[3] Sanganyado E, et al. Chiral pharmaceuticals: A review on their environmental occurrence and fate processes. Water Research 124 (2017), 527-542

Gira a sofre: Disentangling the sulfur cycle in one- and two-chamber bioelectrochemical systems

Shixiang Dai¹, Benjamin Korth¹, Carsten Vogt², Federico Aulenta³, Falk Harnisch^{1*}

¹Department of Environmental Microbiology, UFZ – Helmholtz-Centre for Environmental Research, Leipzig, Germany

²Department of Isotope Biogeochemistry, UFZ – Helmholtz-Centre for Environmental Research, Leipzig, Germany

³Water Research Institute (IRSA), National Research Council (CNR), 00015 Monterotondo, Italy

*Email: falk.harnisch@ufz.de

Wastewaters containing high concentrations of sulfate and being usually deficient of organics are commonly produced in industrial processes and need to be treated before discharged in the environment. Cathodes of bioelectrochemical systems (BESs) have been applied for treatment of sulfate-rich wastewaters by providing reducing power. [1] However, the underlying mechanistic details of removal, for instance the electron transfer mechanism at the cathode, remained often speculative. For shedding light on this, we investigated sulfate reduction in one- and two-chamber microbial electrolysis cells (MECs). The results show that sulfate was fully reduced to sulfide that was accumulating only in two-chamber MECs. Hydrogen-driven dissimilatory sulfate reduction by microbial communities (with ongoing genetic analysis) that developed in the two-chamber system was further proven by microcosm experiments. However, no net sulfate reduction occurred in one-chamber MECs that we so far now tentatively assign to the anodic re-oxidation of sulfide to sulfate by either abiotic or biotic reactions. In principle, such an interesting sulfur cycle, while hampering sulfate removal from wastewater could be exploited to stimulate the sulfate-driven oxidation of organic contaminants in e.g., contaminated soil and groundwater, by continuously regenerating the metabolic electron acceptor.

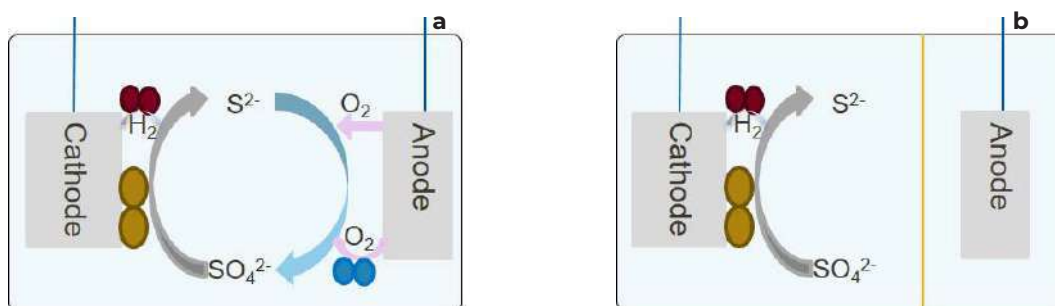

Fig. 1 Sketch of sulfate reduction in 1a in one- and 1b two-chamber MEC, with the different dots representing (so far assumed) microbial traits: brown and red dots represent sulfate reducing bacteria which are electroautotrophs and hydrogenautotrophs and the blue dots represent sulfide oxidizing bacteria.

Keywords: bioelectrochemical system, microbial electrolysis cell, sulfate reduction, sulfur cycle, performance comparison

Funding: This work was supported by the Helmholtz-Association in the frame of the Integration Platform "Tapping nature's potential for sustainable production and a healthy environment" at the UFZ. SD thanks China Scholarship

Council (CSC201804910500) for 4-year granting study abroad.

References

1. Agostino V, Rosenbaum MA (2018): Sulfate-Reducing ElectroAutotrophs and Their Applications in Bioelectrochemical Systems. *Frontiers in Energy Research* 6:55

Primary Sludge-Based Blackwater Favors COD Conversion to Electrons Over Methane in Microbial Electrochemical Cells

Jessica A. Deaver¹, Clancy A. Kerr¹, Sudeep C. Papat^{1,*}

¹Clemson University: 342 Computer Court, Anderson, SC, USA: 29625

*Email: spapat@clemson.edu

Microbial electrochemical cells (MEC) utilize microbial degradation of organic matter in high strength waste coupled with the metabolism of anode-respiring bacteria to produce an electrical current useful for producing electricity or other chemicals.

One application is decentralized blackwater treatment. MEC optimization relies on maximizing recovery of electrons from oxidized organics as electrical current and preventing undesirable electron diversion to alternate sinks, namely methane via methanogenic archaea. We studied conversion of primary sludge-based synthetic blackwater (PS-BW) to quantify the proportion of electrons respired to the anode versus the proportion diverted to methane. To do so, we operated five two-chamber MEC; two were fed PS-BW with high ammonia nitrogen concentrations, and two were fed PS-BW with low ammonia nitrogen concentrations, mimicking combined and source-separated blackwater, respectively.

The final MEC was an inoculum-only control. The high and low ammonia PS-BW conditions yielded 22.6% and 22.8% COD conversion to electrons, respectively, and 0.075% and 0.66% COD conversion to methane, respectively.

Simultaneously run biochemical methane potential tests demonstrated methane production was possible from the PS-BW and inoculum. Thus, treatment of PS-BW appears to favor conversion to electrons over methane. Microbial community analyses will reveal the makeup of the anode biofilm and suspension microbial communities involved.

Keywords: microbial electrochemical cells, anode-respiring bacteria, synthetic blackwater, microbial communities

Funding: NASA SC Space Grant Consortium GRA 2020-2021

Treatment and reuse of wastewater based on METland[®] technology

Lorena Peñacoba-Antona^{1,2,3}*, Mario Jimenez-Conde^{1,2,3}, Junkal Landaburu-Aguirrea¹, Serena Molina¹, Eloy García-Calvo^{1,3}, Abraham Esteve-Núñez^{1,3}

¹ IMDEA Water Institute, Av. Punto Com, 2, Parque Científico Tecnológico, 28805 Alcalá de Henares, Madrid, Spain.

² METfilter S.L., Autovía A49 Sevilla-Huelva Km 28, 41820 Carrión de los Céspedes, Sevilla, Spain.

³ Universidad de Alcalá, Departamento de Química Analítica, Química Física e Ingeniería Química, Ctra. Madrid-Barcelona Km. 33.600, 28871, Alcalá de Henares (Madrid), Spain.

Email: lorena.penacoba@imdea.org

Water scarcity is one of the main concerns for present and future generations. Indeed, the Sustainable Development Goals recognize “Clean water and sanitation” as one of the lines of action for promoting prosperity while protecting the planet. Pursuing this objective, a large-scale wastewater treatment has been developed merging the innovative METland technologies and ultrafiltration by recycled reverse osmosis membranes.

METland[®] is based on the integration of two concepts: Microbial Electrochemical Technologies (MET) and Constructed Wetlands (CW), systems that imitate nature to treat wastewater [1,2]. The electroactive bacteria interact with the electroconductive bed material increasing the electron availability within the system; thus, enhancing the removal of pollutants, without using external energy. Therefore, METlands are able to sustainably treat wastewater in the same place where it is produced [3], and generate reclaimed water for reuse. The full-scale treatment is divided in three phases (Fig. 1): 1) primary treatment-Imhoff tank, 2) down-flow METland[®] [2] and 3) ultrafiltration [4].

The performance of the system achieves an average removal of 95% for COD and 91% for TN, fulfilling the limits of discharge. To sum up, METland systems arise as a suitable and innovative alternative for treating wastewater with a possible reuse after an ultrafiltration process.

Treatment and reuse of wastewater based on METland® technology

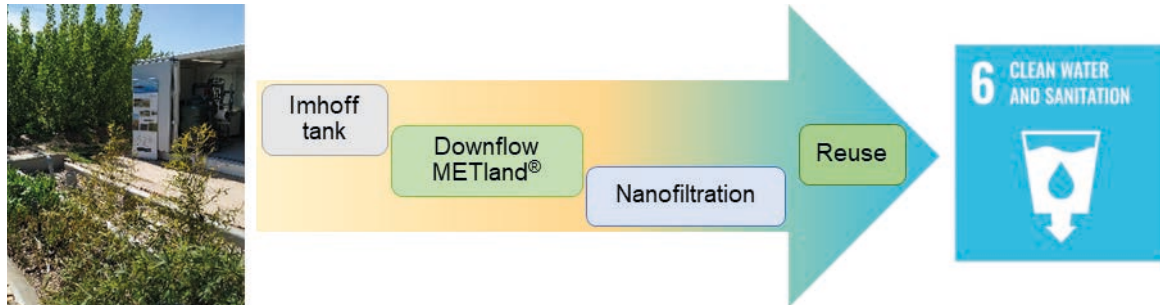

Fig. 1 Photo of the METland system in the facilities of IMDEA Water and the diagram of the wastewater treatment design.

Keywords: wastewater treatment, constructed wetland, METland, water management, reclaimed water

Funding: This investigation has received funding from the European Union's Horizon 2020 research and innovation program under the grant agreement No. 642190 (Project "iMETland"; www.imetland.eu) and No. 826244 (Project "ELECTRA"; www.electra.site). Lorena Peñacoba-Antona and Mario Jimenez-Conde were funded by the industrial PhD fellow-

ship program from the Regional Government of Madrid, Ref. IND2017/AMB-7648 and IND2018/AMB-9197.

References

- [1] Aguirre-Sierra, A. et al. A new concept in constructed wetlands: assessment of aerobic electroconductive biofilters. *Environmental Science: Water Research & Technology*, 2020, 6 (5), 1312-1323.
- [2] Peñacoba-Antona, L. et al. Assessing METland® design and performance through LCA: techno-environmental study with multifunctional unit perspective. *Frontiers in Microbiology*, 2021.
- [3] Peñacoba-Antona, L. et al. Multi-Criteria Evaluation and Sensitivity Analysis for the Optimal Location of Constructed Wetlands (METland) at Oceanic and Mediterranean Areas. *International Journal of Environmental Research and Public Health*, 2021, 18 (10), 5415.
- [4] García-Pacheco, R. et al. Transformation of end-of-life RO membranes into NF and UF membranes: evaluation of membrane performance. *Journal of Membrane Science*, 2015, 495, 305-315.

Purple phototrophic bacteria in microbial electrochemical fluidized-like bed reactors for brewery wastewater treatment

Carlos Manchon^{1,2,*}, Fernando Muniesa-Merino², Yeray Asensio¹ and Abraham Esteve-Núñez¹

¹ Universidad de Alcalá, Department of Chemical Engineering, Alcalá de Henares, Madrid, 28871

² Nanoelectra, Av. Punto Com, 2, Alcalá de Henares, Madrid, 28805

*Email: carlos.mvallegas@gmail.com

The need for sustainable reuse of resources is giving rise to a new model in wastewater treatment based on circular economy. Wastewater treatment with Purple Phototrophic Bacteria (PPB) is one of the most promising applications in the nutrient recovery framework, since they have a high protein content and synthesize added value products. Recently, it has been shown that microbial electrochemical systems are a successful platform that allows modulating the metabolism of these microorganisms [1, 2]. This work aims to apply electro-fermentation in brewery wastewater treatment using PPB. For this purpose, we studied the effect of polarization and Infrared (IR) illumination (for promoting PPB growth) in microbial electrochemical fluidized bed reactors (ME-FBR) [3].

Our results demonstrate that anodic polarization in combination with IR illumination, allows approximately a 2-fold enhancement in terms of total organic carbon removal and total nitrogen removal from brewery wastewater. The production of PPB-biomass was lower under polarization in comparison with electrode-free conditions, which suggest that anodic potential could serve to modulate biomass production. Finally, Illumina analyses showed that *Geobacter* was the electroactive genus that dominates non-illuminated ME-FBR while treating wastewater. In contrast, in illuminated ME-FBR the electroactive genus *Proteiniphilum* together *Rhodopseudomonas* and *Rhodobacter* outcompeted *Geobacter*.

Keywords: purple phototrophic bacteria, electro-fermentation, nutrient recovery

Funding: MET-FLUID (No. RTI2018-101974-B-C-21) from the Spanish Ministry of Science and Innovation and the industrial doctorate programme (No. IND2020/AMB-17843) from the Autonomous Community of Madrid.

References

- [1] Vasiliadou, I. A., et al. Biological and bioelectrochemical systems for hydrogen production and carbon fixation using purple phototrophic bacteria. *Frontiers in Energy Research*, 2018, 6: 107.
- [2] Guzman, M. S., et al. Phototrophic extracellular electron uptake is linked to carbon dioxide fixation in the bacterium *Rhodopseudomonas palustris*. *Nature communications* (2019), 10(1), 1-13.
- [3] Asensio, Y., et al. Upgrading fluidized bed bioelectrochemical reactors for treating brewery wastewater by using a fluid-like electrode. *Chemical Engineering Journal* (2021), 406, 127103.

Electrobioremediation of soil polluted with the insecticide Lindane

Andres de Deus ^{1,2,*}, Estíbaliz Díaz ³, Isabel Coletto ³, Fernando Muniesa-Merino ², Abraham Esteve-Núñez ^{1,2,4}

¹ Universidad de Alcalá, Alcalá de Henares, Madrid, Spain, 28801

² Nanoelectra S.L., Parque Tecnológico de la Universidad de Alcalá, Madrid, Spain, 28805

³ Talantia, Inspira Workspaces Abascal, Madrid, Spain, 28003

⁴ IMDEA-WATER, Parque Tecnológico de la Universidad de Alcalá, Madrid, Spain, 28805

*Email: andres.dedeus@uah.es

Lindane (C₆H₆Cl₆, γ-hexachlorocyclohexane, γ-HCH) was widely used as a broad spectrum insecticide in agriculture since the 1940s. Massive amounts were produced in Sabiñanigo (Spain) between 1975 and 1992, leading to vast soil areas heavily polluted with different Lindane waste isomers including intermediates [1].

We have design and constructed a Microbial electro-remediating cells (MERCs) [2], to be implemented in outdoor mesocosm (0.5m³) made of a real lindane polluted soil with the purpose of stimulating the electrobioremediation of the insectide. A number of electrochemical configurations were tested, together with the use of humic amendment. Our results revealed the biocathode configuration as the most efficient for removing lindane (>70% in 20 weeks) and related chlorinated compounds (>90% γ-HCH in 20 weeks, majority isomer). Microbial community analysis by Illumina from electrode colonizing biofilm appeared more specialized in the case of biocathode, increasing the presence of sulfate-reducing bacteria as *Desulfosporosinus*, sulfur-reducing bacteria as *Dethiobacter* and other anaerobic bacteria as *Anaerorahbdus* y *Howardella*. On the other hand, bioanode and snorkel configurations presented more biodiversity. The bioanodes show a high abundance of *Geobacter*, *Pseudomonas* and *Tolomonas* (electroactive and aromatic-degrading bacteria).

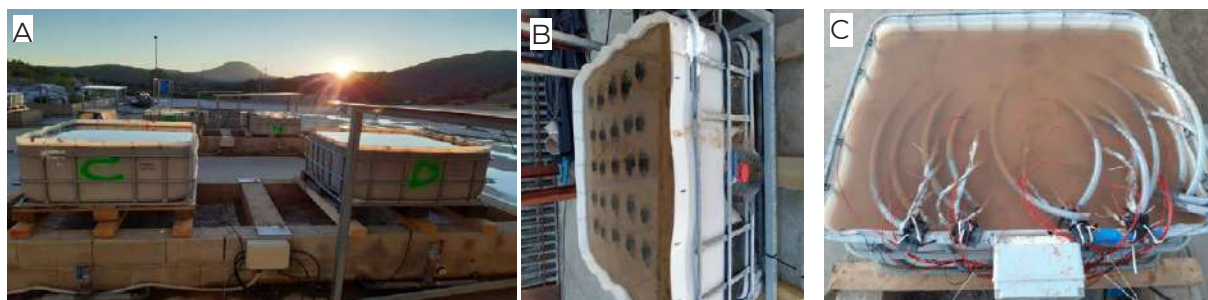

Fig. 1. Photos of A) whole systems, B) snorkel system and C) cathode system

Keywords: electrobioremediation, lindane, HCH isomers, soil remediation, real site pollution.

Funding: Andres de Deus was

funded by a regional Industrial PhD fellowship from the Community of Madrid (IND2017/AMB-7703)

References

[1] Vijgen J, et al. Hexachlorocyclohexane (HCH) as new Stockholm Convention POPs—a global pers-

pective on the management of Lindane and its waste isomers. *Environ Sci Pollut Res.* 2011;18(2):152-162.

[2] Rodrigo Quejigo J, et al. A. Anodic shifting of the microbial community profile to enhance oxidative metabolism in soil. *Soil Biol Biochem.* 2018;116:131-138.

Simultaneous removal of oxidable and reducible contaminants from groundwater with the “bioelectric well”

Matteo Tucci¹*, Alessandro Milani¹, Camilla De Laurentiis¹, Marco Resitano¹, Carolina Cruz Viggi¹, Simona Crognale¹, Bruna Maturro¹, Simona Rossetti¹, Falk Harnisch², Federico Aulenta¹

¹ Water Research Institute (IRSA), National Research Council (CNR), Via Salaria km 29300, 00015 Monterotondo (RM), Italy

²Department of Environmental Microbiology, Helmholtz Centre for Environmental Research GmbH - UFZ, Permoserstraße 15, Leipzig, 04318, Germany

*Email matteo.tucci@irsa.cnr.it

Groundwater contamination is a critical issue that poses serious health and environmental risks. In this context, Microbial Electrochemical Technologies (METs) are being considered as an alternative to traditional groundwater remediation techniques. Indeed, they possess the advantage of avoiding addition of electron acceptors (or donors) in the aquifer to promote oxidation (or reduction) of contaminants, thus being potentially more sustainable and cost-effective [1].

Herein, a lab-scale bioelectrochemical reactor named “bioelectric well” [2–4] was continuously fed with artificial groundwater containing a mixture of oxidable (*i.e.*, toluene) and reducible (*i.e.*, chlorinated solvents) contaminants. The reactor consisted in a tubular glass cylinder where in a cylindrical graphite anode and a stainless-steel mesh cathode were concentrically placed. Anode and cathode were kept physically separated yet hydraulically connected using a polyethylene mesh. Throughout the experiment, the anode was polarized at +0.2 V vs. SHE.

The performances of the system were evaluated in terms of toluene and chlorinated solvents removal and coulombic efficiency, and they were compared to an open circuit control. Moreover, the microbial composition of the biofilm and of the bulk liquid was analysed by NGS methods. Our findings highlight the benefits of the bioelectrochemical system on the remediation process.

Keywords: Microbial electrochemical technologies, groundwater remediation, bioremediation, toluene, petroleum hydrocarbons

Funding: This study was supported by the European Union’s Horizon 2020 project ELECTRA (www.electra.site) under grant agreement No. 826244.

References

[1] M. Daghigho, F. Aulenta, E. Vaiopoulou, A. Franzetti, J.B.A. Arends, A. Sherry, A. Suárez-Suárez, I.M. Head, G. Bestetti, K. Rabaey,

Electrobioremediation of oil spills, *Water Res.* 114 (2017) 351–370. doi:10.1016/j.watres.2017.02.030.

[2] E. Palma, A. Espinoza Tofalos, M. Daghigho, A. Franzetti, P. Tsiota, C. Cruz Viggi, M.P.M.P. Papini, F. Aulenta, Bioelectrochemical treatment of groundwater containing BTEX in a continuous-flow system: Substrate interactions, microbial community analysis, and impact of sulfate as a co-contaminant, *N. Biotechnol.* 53 (2019) 41–48. doi:10.1016/j.nbt.2019.06.004.

[3] E. Palma, M. Daghigho, A. Espinoza Tofalos, A. Franzetti, C. Cruz Viggi, S.

Fazi, M. Petrangeli Papini, F. Aulenta, Anaerobic electrogenic oxidation of toluene in a continuous-flow bioelectrochemical reactor: Process performance, microbial community analysis, and biodegradation pathways, *Environ. Sci. Water Res. Technol.* 4 (2018) 2136–2145. doi:10.1039/c8ew00666k.

[4] E. Palma, M. Daghigho, A. Franzetti, M. Petrangeli Papini, F. Aulenta, The bioelectric well: a novel approach for in situ treatment of hydrocarbon-contaminated groundwater, *Microb. Biotechnol.* 11 (2018) 112–118. doi:10.1111/1751-7915.12760.

Combined Electrochemical Water Softening And Nitrate Electro Bioremediation

Alba Ceballos-Escalera*, Narcís Pous, M. Dolors Balaguer, Sebastià Puig

LEQUiA, Institute of the Environment, University of Girona, C/ Maria Aurèlia Capmany, 69, Girona, Spain, E-17003

*Email: alba.ceballoescalera@udg.edu

Electro bioremediation of nitrate-contaminated groundwater has been successfully investigated at laboratory-scale¹solubility, and mobility. Nevertheless, the actual treatment implementation is in an ambitious transition. Groundwater hardness may generate scale deposits that irreversibly affect the treatment effectiveness. The present study aims at using electrochemical water softening implementation as a sustainable preliminary step for nitrate electro bioremediation. A single-chamber reactor was operated at a cathode potential of -1.2 V vs. Ag/AgCl in continuous flow-mode (HRT of 4.1h). The electrochemical reactor achieved a hardness removal efficiency of $64\pm4\%$ (305 ± 17 mg CaCO_3 m^{-2} cathode h^{-1}) over 13 days until the cathode was covered with precipitate and chemical cleaning was required. The softening life-time was increased by 48% once polarity reversal¹ strategy was applied. Softened groundwater was introduced into the nitrate electro bioremediation treatment², which achieved a nitrate removal effectiveness of $97\pm1\%$ (1269 ± 30 g NO_3^- m^{-3} $\text{net cathode compartment d}^{-1}$) in continuous flow-mode (HRT_{cat} of 2.1h) under a cathode potential of -0.32 V vs. Ag/AgCl. The effluent reached the quality standards of drinking water in terms of concentration of nitrates and nitrite (Nitrates Directive, 91/767/EU). The estimated energy consumption of 1.4 kWh m^{-3} confirmed the competitiveness of the combined treatment, paving the ground for future scaling up the process.

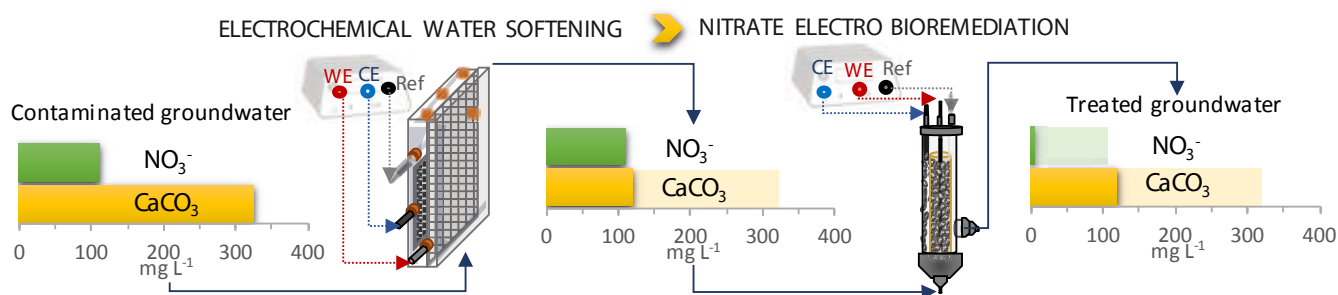

Fig. 1. Schematics of the combined treatment: electrochemical softening (left) and nitrate electro bioremediation (right). Groundwater composition (hardness and nitrate) in each step.

Keywords: Nitrate-polluted groundwater, Hardness removal, Polarity reversal, Denitrifying bioelectrochemical system.

Funding: This work was funded by European Union's Horizon 2020 project ELECTRA [No. 826244]. A.C-E. was supported by a PhD grant from the University of Girona (IF_UDG2020). S.P. is a Serra Hunter Fellow (UdG-AG-575) and acknowledges the funding from the ICREA Academia award.

References

- Jin H, et al. Polarity reversal electrochemical process for water softening. *Sep. Purif. Technol.*, 2019, 210: 943. Ceballos-Escalera A, et al. Electro-bioremediation of nitrate and arsenite polluted groundwater. *Water Res.*, 2021, 190: 116748

Soil Microbial Fuel Cell for Bioremediation of Recalcitrant Hydrocarbons

Arpita Nandy¹, Bongkyu Kim¹, Mirella Di Lorenzo*

¹ Department of Chemical Engineering and Centre for Biosensors, Bioelectronics & Biodevices (C3Bio), University of Bath, Claverton Down, BA2 7AY, UK

Increased human, agricultural and industrial activities along with improper waste disposal leads to high levels of soil contamination and accumulation of recalcitrant contaminants. This global issue demands the use of green and sustainable technologies and soil microbial fuel cells (SMFC) can be a potential solution. In this presentation, we will give an overview of the efficacy of the SMFCs for remediation and elucidate the advantages of SMFC over natural bioremediation. We adopted minimalistic design based on low-cost carbon materials without any expensive catalyst and membrane, which makes the SMFCs suitable for upscaled in-field applications. We particularly studied the removal of hydrocarbons over time and advanced chromatographic techniques are used to analyse the fractions of total petroleum hydrocarbons (TPH) and 16 polycyclic aromatic hydrocarbons (PAH), which are extremely hazardous to the environment and humans and listed as priority pollutants by USEPA [1]. Natural hydrocarbon remediation is time consuming and suffers from poor bioavailability. We have designed experiments to address these issues and compared the findings to understand how these modifications can facilitate the degradation process.

This study aims to elucidate the advantages of SMFCs for efficient removal of contaminants in soil with the generation of clean energy, towards a promising self-sustainable technology.

Keywords: Soil microbial fuel cells, Bioremediation, Low-cost, Hazardous, Hydrocarbons

Funding: This work is part of the project GREENER that has received funding from the European Union's Horizon 2020 research and innovation programme under the grant agreement No 826312

References

- [1] U.S. Environmental Protection Agency, 1993. Provisional guidance for quantitative risk assessment of polycyclic aromatic hydrocarbons. EPA 600-R-93-089.

Groundwater denitrification by expanded bioelectrochemical systems

Xiaofei Wang^{1,2}, Korneel Rabaey^{1,2*}

¹ Center for Microbial Ecology and Technology (CMET), Ghent University, Coupure Links 653, 9000, Ghent, Belgium

² Centre for Advanced Process Technology for Urban Resource Recovery (CAPTURE), Frieda Saeystraat 1, 9000 Ghent, Belgium * Corresponding author. E-mail address: korneel.rabaey@ugent.be . URL: <http://www.capture-resources.be>

More than 30% of groundwater sources in the EU contain more nitrate than the drinking water standard. Bioelectrochemical system (BES) was proven to be an effective method for groundwater denitrification by autotrophs at low energy investment and without chemical addition^{1,2}. However, the most commonly studied fixed-bed systems suffer from fouling issues, which prevents larger scale application. A new concept applying expanded cathode could potentially solve the problem and allow for a dramatic expansion of the working volume, where biofilmed cathodic particles moving in the cathodic chamber with intermittent contact with electron donors. To investigate the impact of intermittent access of electrons on denitrification performance, two approaches were tested: 1. Periodic polarization on packed-bed biocathodes; 2. Continuous polarization on expanded-bed biocathodes. The first approach showed that the electroactive biofilm developed a higher ability for electron storage and transfer at an intermittent power supply (30s open circuit/30s polarization) at a cathodic potential of -0.4V vs. Ag/AgCl, with 86% nitrate removal at a denitrification rate of 205 g NO₃⁻-N /m³/d. However, on expanded-bed biocathodes, denitrification only occurred with H₂ evolution at a cathodic potential lower than -1V vs. Ag/AgCl, with 92% nitrate removal at a denitrification rate of 155 g NO₃⁻-N /m³/d. The preliminary results from this work could provide a better understanding of the electron transfer in the bioelectrochemical denitrification process and support future reactor design.

Keywords: denitrification, BES, periodic polarization, expanded-bed biocathodes

Funding: Horizon 2020 ELECTRA Project, grant agreement No 826244.

References

- (1) Pous, N.; Balaguer, M. D.; Colprim, J.; Puig, S. Opportunities for Groundwater Microbial Electro-Remediation. *Microb. Biotechnol.* **2018**, *11* (1), 119–135. <https://doi.org/10.1111/1751-7915.12866>.
- (2) Wang, X.; Aulenta, F.; Puig, S.; Esteve-Núñez, A.; He, Y.; Mu, Y.; Rabaey, K. Microbial Electrochemistry for Bioremediation. *Environ. Sci. Ecotechnology* **2020**, *1*, 100013. <https://doi.org/10.1016/J.ESE.2020.100013>.

Electro-bioremediation of nitrate from saline groundwater and concomitant chlorine production

Giulia Puggioni^{1,2,*}, Stefano Milia³, Emma Dessì¹, Valentina Unali³, Narcis Pous², M. Dolors Balaguer², Sebastià Puig², Alessandra Carucci^{1,3}

¹ University of Cagliari – Department of Civil-Environmental Engineering and Architecture (DICAAR), Via Marengo 2 - 09123, Cagliari, Italy

² Laboratory of Chemical and Environmental Engineering (LEQUiA), Institute of the Environment, University of Girona, Carrer Maria Aurelia Capmany, 69, E-17003 Girona, Spain

³ National Research Council of Italy - Institute of Environmental Geology and Geoengineering (CNR-IGAG), Via Marengo 2 - 09123, Cagliari, Italy

*Email: giulia.puggioni@unica.it

Groundwater pollution and salinization have increased steadily over time [1,2], therefore a sustainable approach to the recovery of such important water resource has become essential.

A 3-compartment cell configuration was tested for the simultaneous denitrification and desalination of nitrate contaminated saline groundwater. The reactors were initially operated in potentiostatic mode to promote autotrophic denitrification at the biocathode [3], and then switched to galvanostatic mode to improve desalination in the central compartment. The average nitrate removal rate was $39 \pm 1 \text{ mgNO}_3^- \text{-N L}^{-1} \text{d}^{-1}$ and no intermediates (nitrite and nitrous oxide) were observed in the effluent. Groundwater salinity was considerably reduced (average chloride removal was $63 \pm 5\%$). Within a circular economy approach, part of the removed chloride was recovered in the anode compartment and converted into chlorine. Production rates of $6.1 \text{ mgCl}_2 \text{ L}^{-1} \text{d}^{-1}$ were achieved, corresponding to a concentration of $26.8 \pm 3.4 \text{ mgCl}_2 \text{ L}^{-1}$. The accumulated chlorine represents a value-added product, which could also be dosed for the disinfection of treated water. This proof-of-concept configuration was able to meet WHO and European legislation for drinking water in terms of nitrate and salinity, with low specific power consumptions ($0.13 \pm 0.01 \text{ kWh g}^{-1} \text{NO}_3^- \text{N}_{\text{removed}}$). These results pave the ground to develop a sustainable technology which tackles an urgent environmental issue.

Keywords: circular economy; denitrification; disinfectant products; saline groundwater; value-added products.

Funding: This research was funded by Fondo di Sviluppo e Coesione 2014-2020, Patto per lo sviluppo della Regione Sardegna - Area Tematica 3 - Linea d' Azione 3.1, "Interventi di sostegno alla ricerca". Project SARDNAF "Advanced Systems for the Removal of Nitrates from Groundwater", ID: RASSR53158. S.P. is a Serra Hunter Fellow (UdG-AG-575) and acknowledges the funding

from the ICREA Academia award. LEQUiA has been recognized as a consolidated research group by the Catalan Government (2017-SGR-1552).

References

[1] Menció A., et al., «Nitrate pollution of groundwater; all right..., but nothing else?», *Science of The Total Environment*, vol. 539, pag. 241–251, gen. 2016, doi: 10.1016/j.scitotenv.2015.08.151.

[2] Troudi N., et al., «Assessment of groundwater quality for drinking purpose with special emphasis on salinity and nitrate contamination in the shallow aquifer of Guenniche (Northern Tunisia)», *Environ Monit Assess*, vol. 192, n. 10, pag. 641, ott. 2020, doi: 10.1007/s10661-020-08584-9.

[3] Ceballos-Escalera A., et al., «Electro-bioremediation of nitrate and arsenite polluted groundwater», *Water Research*, vol. 190, pag. 116748, feb. 2021, doi: 10.1016/j.watres.2020.116748.

Power Generation from Constructed Wetland Microbial Fuel Cells under Batch and Continuous Flow

Miranda-Méndez, Oscar¹ Durán-Domínguez, María del Carmen² Salinas-Juárez, María G.^{2*}

¹ Facultad de Química, Universidad Nacional Autónoma de México, Address Circuito de la Investigación Científica s/n, Ciudad Universitaria, Mexico City, Mexico, Postal code: 04510.

² Facultad de Estudios Superiores Zaragoza Universidad Nacional Autónoma de México, Batalla 5 de mayo S/N Esquina Fuerte de Loreto, Col. Ejército de Oriente, Iztapalapa, Mexico City, Mexico, Postal code: 09230.

*Email: maria.salinas@outlook.com

An electric current can be recovered from the metabolic activity of microorganisms through an electrochemical system in a constructed wetland microbial fuel cell (CW-MFC). Furthermore, artificial wetlands can take advantage of its own processes for simultaneously treating wastewater and producing electricity. The aim of this research was to determine whether a continuous or an intermittent flow reactor has the best performance on power generation and pollutants removal. Two experimental systems were constructed, the first one under continuous flow, and the second, in batch flow mode, and varying the external electrical resistance (5,600, 1,000, 560, and 10 Ω) over various stages (17–20 days). Results indicate that reactors operating in batch mode provided a higher organic matter removal (average 94%), while the reactor operated in continuous mode had a power output of 18.12 mW/m², which is 1.6 times more than the power produced by the batch reactor. The highest power density occurred during the 5600 Ω of electrical resistance connection in continuous mode, indicating the external resistance influence. Therefore, operating the reactors in a continuous mode leads to stable organic matter removals and power production. Operating in batches destabilizes the electrical parameters values when the reactor is emptied and filled.

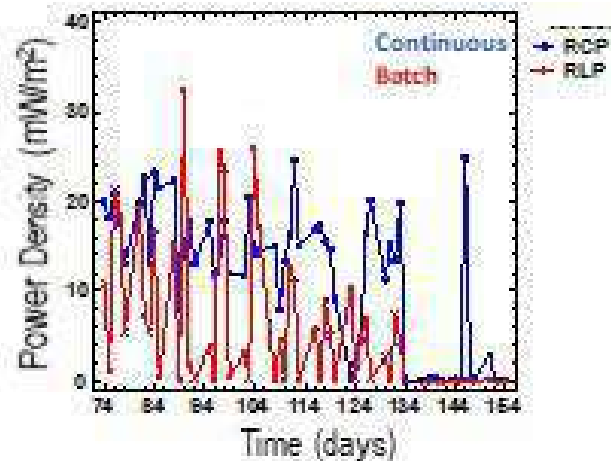

Fig. 1 Power density produced by the two experimental systems

Keywords: Constructed wetlands; Microbial fuel cells; Continuous flow, Batch mode

Funding: This study was funded by the Program to Support Research and Graduate Studies (PAIP, in Spanish) of Facultad de Química, UNAM, Code 50009067.

References

- [1] Strik D, et al. Green electricity production with living plants and bacteria in a fuel cell. *Int. J. of energy Research*. 2008, 32. 870-876.
- [2] Salinas-Juárez M.G, et al. Plant and microorganisms support media for electricity generation in biological fuel cells with living hydrophytes. *Bioelectrochemistry*, 2016, 112:145-152.
- [3] Das B, et al. Batch investigation of constructed wetland microbial fuel cell with reverse osmosis (RO) concentrate and wastewater mix as substrate. *Biomass and Bioenergy*, 2019,122, 231–237.

Lowering energy consumption of a sequential reductive/oxidative bioelectrochemical process for CAHs removal by a galvanostatic polarization strategy

Marco Zeppilli*, Edoardo Dell'Armi, Elena di Carlo,
Marco Petrangeli Papini, Mauro Majone

¹ Department of Chemistry University of Rome Sapienza,
Piazzale Aldo Moro 5, 00185 Rome, Italy

*Email: marco.zeppilli@uniroma1.it

A sequential reductive/oxidative bioelectrochemical process for chlorinated aliphatic hydrocarbons (CAHs) removal from groundwater has been developed by the combination of two membrane-less microbial electrolysis cells named reductive and oxidative reactor, respectively. In almost two years of continuous-flow operation of the sequential process, several operating conditions have been characterized including hydraulic retention time, applied potential and contaminated matrixes (mineral medium, synthetic groundwater, real groundwater). Most of the explored conditions were investigated under potentiostatic control of the cell, which in presence of side reactions like sulphate and nitrate reduction, promoted an increase of energy consumption of the process due to the side reaction contribution to the current increase. The removal of CAHs in groundwater typically requires low amounts of equivalents due to the low solubility of the CAHs, in this way, an interesting approach for energy consumption minimization is offered by the adoption of a galvanostatic approach which allows for the control of the available current in the cell. In this study, the use of a galvanostatic approach for the minimization of the energy consumption of the reductive and oxidative dechlorination has been analysed in both reductive and oxidative reactors even in presence of side reactions like sulphate and nitrate reduction.

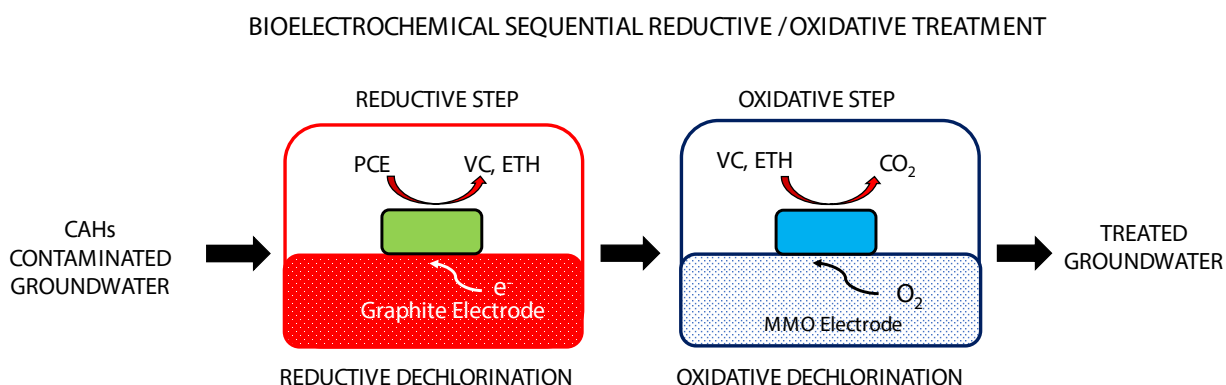

Fig.1: Schematic concept of sequential reductive/oxidative bioelectrochemical process

Keywords: Chlorinated Aliphatic Hydrocarbons, bioremediation, galvanostatic control, potentiostatic control, reductive Dechlorination, Oxidative Dechlorination

Funding: This project has received funding from the European Union's Horizon 2020 research and innovation programme under grant agreement No 826244-ELECTRA

Chlorinated aliphatic hydrocarbons (CAHs) removal from a real groundwater by a sequential Reductive/Oxidative Bioelectrochemical process

Edoardo Dell'Armi¹, Marco Zeppilli¹, Letizia Di Franca², Bruna Matturro², Simon Rossetti², Feigl Viktória Dóra³, Mónika Molnár³, Zsófia Berkl³, Mauro Majone¹, Marco Petrangeli Papini¹

¹ "Sapienza" University of Rome, Piazzale Aldo Moro 5, Rome, Italy, 00185

² Water Research Institute – Council of National Research (IRSA-CNR), Via Salaria Km 29.300, Monterotondo (RM), Italy, 00015

³ Budapest University of Technology and Economics, Department of Applied Biotechnology and Food Science, Műgyetem rkp. 3. Budapest H-1111, Hungary.

*Email edoardo.dellarmi@uniroma1.it

A reductive/oxidative bioelectrochemical process has been developed by connecting in series two membrane-less microbial electrolysis cells (MECs) equipped with an internal graphite counterelectrode¹ avoiding the use of an ion exchange membrane to separate the anodic and cathodic chamber and reducing the cost of the reactor. In the reductive reactor, a dechlorinating mixed inoculum received reducing power to perform the reductive dechlorination of perchloroethylene (PCE). The first MEC aimed at the CAHs reductive dechlorination (RD) and was constituted by a granular graphite working electrode while the second MEC, devoted to the oxidative dechlorination of low chlorinated RD

by-products, utilized a MMO working electrode for the electrolytic oxygen production². In the present study, the sequential reductive/oxidative bioelectrochemical process has been tested with real groundwater from a contaminated site located in northern Italy. The sequential process allowed for the complete mineralization of the CAHs contained in the real groundwater by the complete reduction of CAHs into vinyl chloride (VC) in the first MEC polarized at -450 mV vs SHE, while all the VC was successfully oxidized by the HRT increase from 0.7 to 1.7 days in the second MEC (operated at +15 mA). Biomarkers of the reductive (*Dehalococcoides mccartyi* 16S rRNA and dehalogenase genes) and oxidative (etnE, etnC genes) dechlorination in the two MECs have been monitored along with the ecotoxicity tests to assess the potential adverse effects and to provide information on the efficiency of the applied technology.

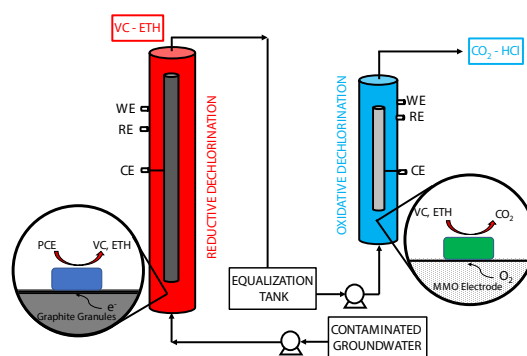

Fig.1: Schematic representation of the sequential reductive/oxidative bioelectrochemical process

Keywords: Bioremediation, Chlorinated Aliphatic Hydrocarbons, Reductive Dechlorination, Oxidative Dechlorination

Funding: This project has received funding from the European Union's Horizon 2020 research and innovation programme

under grant agreement No 826244-ELECTRA

References

1. Zeppilli, M., Dell'Armi, E., Cristiani, L., Papini, M. P. & Majone, M. Reductive/oxidative sequential bioelectrochemical process for perchloroethylene removal. *Water (Switzerland)*

11, (2019).

2. Dell'Armi, E., Zeppilli, M., Matturro, B., Rossetti, S. & Petrangeli Papini, M. Effects of the Feeding Solution Composition on a Reductive / Oxidative Sequential Bioelectrochemical Process for Perchloroethylene Removal. *Processes* (2021).

Promising affordable separators for microbial electrolysis cells

Óscar Santiago¹, Max Bringmann¹, Isaac Vázquez¹, Sven Kerzenmacher¹

¹ Center for Environmental Research and Sustainable Technology (UFT), University of Bremen, Leobener Str. 6, Bremen 28359, Germany

*Email: santiago@uni-bremen.de

Microbial electrolysis cells have emerged as a promising technology platform for wastewater treatment and the simultaneous production of hydrogen. It would be desirable to keep hydrogen produced at the cathode separated from potentially hydrogenotrophic organisms, maintaining a low ohmic potential drops across the electrolysis cell. Whereas most ion-exchange membranes can achieve these objectives, their cost is prohibitive for a scaled-up setup¹. Thus, more affordable solutions should be analyzed to reduce the general cost and increase the applicability of this technology.

This work compares several ion-exchange membranes in terms of ohmic resistance, swelling, dimensional and mechanical stability, pH imbalance and cost. Moreover, two non-ion-exchange commercial membranes are included in the comparison set due to their low cost, potentially good transport properties and barrier effect against microorganisms. The performances of the materials are evaluated by means of abiotic experiments under realistic hydraulic operating conditions, using a semi-synthetic brewery wastewater as medium.

Results evidence the differences in the performance of the materials under the same working conditions. Cellophane and a polyethylene acid battery separator show significantly low resistances compared to state-of-the-art ion-exchange membranes (Fig. 1) which profile them as cost and possibly even performance-competitive materials.

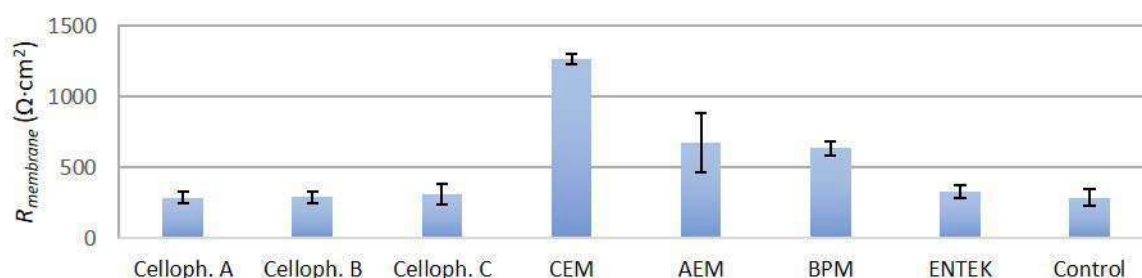

Fig. 1 Resistance of the membranes under study. Celloph. A, Celloph. B and Celloph. C represent three cellophanes provided by different suppliers and Control depicts the experiment carried out without membrane.

Keywords: MEC, ion-exchange membrane, membrane screening,

low-cost separators, ohmic resistance

Funding: We are grateful for the financial support from the Bundesministerium für Bildung und Forschung (BMBF) under the program 02WER1528A.

References

- [1] Streeck, J. *et al.* Bio-electrochemical conversion of industrial wastewater-COD combined with downstream methanol synthesis – an economic and life cycle assessment. *Green Chem.* **2018**, *20* (12), 2742–2762.

Modelling bioelectrochemical reactors for electrobioremediation processes development optimization

Elisa Casula¹, Daniele Molognoni², Bongkyu Kim³, Mirella Di Lorenzo³, Eduard Borràs², Michele Mascia^{1*}

² LEITAT Technological Center, C/ de la Innovació 2, 08225 Terrassa, Spain

¹ Dipartimento di Ingegneria Meccanica, Chimica e dei Materiali, Università degli Studi di Cagliari, Via Marengo 2, 09123, Italy

³ Department of Chemical Engineering and Centre for Biosensors, Bioelectronics & Biodevices (C3Bio), University of Bath, Claverton Down, BA2 7AY, UK

*Email: michele.mascia@unica.it

In the frame of the GREENER Project, two mathematical models for soil and liquid BES reactors have been described. These serve as a tool to design and optimize electrobioremediation systems. On the one hand, a 3D model to describe removal of pollutants in liquid media has been built and solved. This integrates equations of charge conservation with mass transport phenomena, hydrodynamics, and kinetics of the involved processes under transient conditions, such as biofilm formation, bioelectrochemical and electrochemical reactions. Once the model was calibrated with experimental data, different scenarios were investigated, and the relevant results compared: a system with a single BES cell under fed-batch and flow conditions, and a system constituted by three BES cells hydraulically connected in-series. A model to describe tubular terracotta-based soil microbial fuel cells (SMFC) piled together for soil bioremediation was also developed. The model, calibrated with experimental data, predicts the performance of the SMFCs by combining transport phenomena in the solid, liquid and gas phase with (bio)electrochemical reactions, charge balance, evaporation and transport of water and its effect on transport of solutes. The model is also used to predict the efficacy of the piled SMFCs to biodegrade an exemplary persistent organic pesticide, such as hexachlorobenzene.

Keywords: Soil Microbial Fuel Cells, 3D model, electrobioremediation.

Funding: This work is part of the project GREENER that has received funding from the European Union's Horizon 2020 research and innovation programme under the grant agreement No 826312

Taking the waste out of dye wastewater using microbial fuel cells

Dr Godfrey Kyazze.

University of Westminster, London W1W 6UW, United Kingdom

Dye-containing wastewater (e.g. from textiles) is getting ever more challenging to treat partly due to its complexity but also due to tightening legislation regarding discharge standards. In India for example, they have a zero-water discharge policy which means the wastewater has to be treated to such a level that it can be reused. Treatment of the water for reuse is also of interest to water stressed countries. Conventional methods of treatment are however, either too costly (e.g. membrane systems) or produce sludges that create a secondary disposal problem (e.g. flocculation). I will explore the role that microbial fuel cells can play in overcoming some of the challenges of treating dye wastewater using conventional means. Case studies will include anodic vs cathodic decolourisation of dyes, integration of microbial fuel cells with activated sludge systems and scale up of reactors used.

Bio-electrochemical degradability of prospective wastewaters to determine their ammonium recovery potential

S. Georg^{1,2}, C. Schott^{1,2}, J.R. Courela Capita¹, T. Sleutels¹, P. Kuntke^{1,2}, A. ter Heijne^{2*}, C.J.N. Buisman^{1,2}

¹Wetsus, European Centre of Excellence for Sustainable Water Technology, Oostergoweg 9, 8911MA Leeuwarden, the Netherlands

²Environmental Technology, Wageningen University, Bornse Weiland 9, P.O. Box 17, 6700 AA Wageningen, the Netherlands

* Corresponding author: annemiek.terheijne@wur.nl

Bio-electrochemical ammonium recovery (BEAR) can close the cycle between anthropogenic emission of reactive nitrogen and energy intensive nitrogen fixation in the Haber-Bosch process. BEAR is currently limited by the bio-electrogenic degradability of the treated wastewater. Here, we investigated the degradability of blackwater, hydrolyzed human urine, cow manure and pig manure as prospective wastewaters for BEAR in a standardized experimental design.

We found that bio-electrochemical conversion efficiencies ranged from 63% (blackwater), 42% (cow manure) and 41% (urine) to 26% (pig manure) after 5 days. These values correspond well with the relative VFA content of soluble COD for blackwater and cow manure, while additional compounds must have been converted for urine and pig manure.

The degradability of blackwater and cow manure was sufficiently high to theoretically be able to remove all TAN already after <0.5 d. The actual recovery potential (consisting of conversion efficiency and COD/TAN ratio) of pig manure was just high enough to remove all TAN. Human urine would require additional electron donor to remove all TAN in BEAR. Therefore, combining the maximum recovery potential with the relative VFA content of soluble COD can give a good estimate of the actual recovery potential of a wastewater.

	Black water	Urine	Cow manure	Pig manure
Peak current density j [A/m^2]	2.2 ± 0.6	0.6 ± 0.2	2.4 ± 0.1	1.6 ± 0.2
Conversion efficiency after peak [%]	42 ± 8	31 ± 2	36 ± 5	16 ± 2
Conversion efficiency after 5 d [%]	63 ± 4	41 ± 5	42 ± 4	23 ± 2
Acetate / COD_f [$g_{CODf,Ac}/g_{CODf}$] [%]	26	15	28	8
VFAs / COD_f [$g_{CODf,VFAs}/g_{CODf}$] [%]	63	15	40	8
BMP / BMP_{max} [%]	60 [1]	46 – 86 [2]	59 [3]	55 [4]

Fig. 1: Summary of reproducible bio-electrochemical wastewater conversions to electricity from four replicates. BMP / BMP_{max} recalculated from maximum values from [1] de Graaff et al., 2010, [2] Barbosa et al., 2019, [3] Yao et al., 2017 and the highest methane content (56.5–75.5%, [4] Shin et al., 2019) substantial amounts of greenhouse gases (GHG

Keywords: bio-electrochemical systems; wastewater; ammonium recovery; recovery potential; biodegradability

Funding: Horizon 2020 research and innovation programme, Marie Skłodowska-Curie grant agreement No 665874

References

- [1] de Graaff MS, et al. Anaerobic treatment of concentrated black water in a UASB reactor at a short HRT. Water (Switzerland) 2010;2:101–19. <https://doi.org/10.3390/w2010101>.
- [2] Barbosa SG, et al. Anaerobic biological fermentation of urine as a strategy to enhance the performance of a microbial electrolysis cell (MEC). Renew Energy

2019;139:936–43. <https://doi.org/10.1016/j.renene.2019.02.120>.

[3] Yao Y, et al. Simultaneous ammonia stripping and anaerobic digestion for efficient thermophilic conversion of dairy manure at high solids concentration. Energy 2017;141:179–88. <https://doi.org/10.1016/j.energy.2017.09.086>.

[4] Shin SR, et al. Effects of pig slurry acidification on methane emissions during storage and subsequent biogas production. Water Res 2019;152:234–40. <https://doi.org/10.1016/j.watres.2019.01.005>.

Procedure for the screening of anode materials for microbial electrolysis cells operated with brewery wastewater

Isaac Vázquez^{1,*}, Óscar Santiago¹, Sönke Freitag¹, Sven Kerzenmacher¹

¹ Center for Environmental Research and Sustainable Technology (UFT), University of Bremen, Leobener Str. 6, Bremen 28359, Germany

*Email: ivazquez@uni-bremen.de

The meaningful characterization of electrode materials for microbial anodes operated with complex wastewaters can be challenging^[1], in particular due to changes in the medium during characterization owing to the fermentation process, change of the microbial consortium, and composition variations of the real medium used in practical applications.

Thus, a screening method is proposed where various anodes can be simultaneously compared over the time for various medium compositions. Sequential cultivation, stabilization and polarization methods are conducted to systematically compare materials over time (Fig. 1). The evaluation of the polarization curves of the anodes^[2] yields insights on attainable current densities depending on the potential, limiting currents, and sensitivity towards compositional changes in the medium.

It was observed that simultaneous testing allows reliable comparison between anode materials. This strategy provides a framework to assess materials despite different degrees of fermentation of the medium and bypasses problems due to poor conductivity and buffer capacity of the medium.

First results show stainless steel wool has a competitive electrochemical performance with respect to carbon felt, providing higher current densities and limiting current densities. Furthermore, the reproducible compositional variation of the reactors in time suggest a high degree of systematization in medium-term experiments.

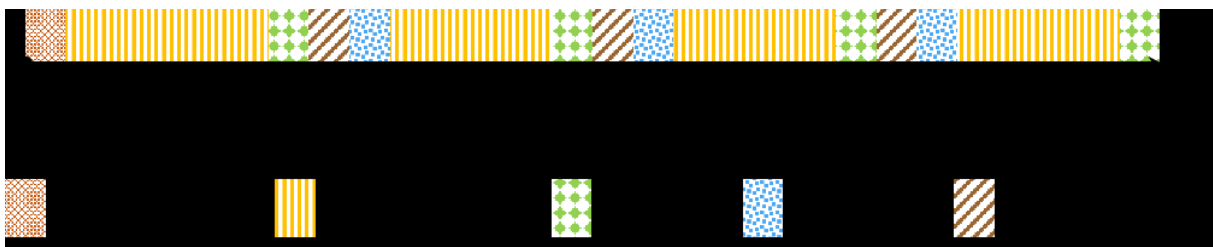

Fig. 1 Scheme of the developed procedure. CA = chronoamperometry, PC = polarization curve.

Keywords: Brewery wastewater, polarization curve, MEC, anode screening, anode respiring bacteria

Funding: We are grateful for the financial support from the

Bundesministerium für Bildung und Forschung (BMBF) under the program O2WER1528A.

References

[1] Leicester, D. *et al.* Is bioelectrochemical energy production from wastewater a reality? Identifying and standardising the progress made

in scaling up microbial electrolysis cells. *Renewable and Sustainable Energy Reviews* **2020**, 133.

[2] Cario, B. P. *et al.* Applying the electrode potential slope method as a tool to quantitatively evaluate the performance of individual microbial electrolysis cell components. *Bioresource Technology* **2019**, 287, 121418.

Magnetite anodes to inhibit oxygen production and to circumvent the use of membranes in microbial electrosynthesis

**N. Rohbohm^{1*}, T. Sun¹, R. Blasco-Gómez¹, J. M. Byrne¹,
A. Kappler¹ and L. T. Angenent¹**

¹ Center for Applied Geosciences, University of Tübingen,
Schnarrenbergstraße 94-96, 72076 Tübingen, Germany.

*Email: nils.rohbohm@uni-tuebingen.de

While studies on microbial electrosynthesis are mostly focused on the cathode, the anode performance is often overlooked [1]. One major product at the anode is oxygen, which is toxic to the anaerobic autotrophs that are involved in microbial electrosynthesis. Therefore, expensive membranes are used to avoid direct contact between these microbes and oxygen. Here, we tested a redox-active, mixed-valent magnetite mineral as an anodic electrode material, which acted as a pseudo-capacitor to inhibit oxygen production with the goal to circumvent membranes for microbial electrosynthesis. Abiotic experiments showed faster reaction kinetics for the oxidation of magnetite compared to the oxygen evolution. Next, we set up single-chamber bioelectrochemical systems (50-mL working volume) with magnetite-based anodes and carbon-based cathodes, and inoculated a hydrogenotrophic methanogen to produce methane at 65°C. Our results showed that the magnetite anode was able to both sustain methane production and avoid oxygen evolution to achieve an average methane production and coulombic efficiency of 21.03 L·m⁻²·d⁻¹ and 76 %, respectively. Mineralogical analyses of the magnetite confirmed its homogenous oxidation during the passing of current. Overall, this study provided a proof-of-concept that demonstrated the suitability of magnetite-based anodes for microbial electrosynthesis, which would make this process more economically feasible.

Keywords: Microbial electrosynthesis, Magnetite anode, Oxygen inhibition, Membrane circumvention

Funding: Alexander von Humboldt Foundation by the Federal Ministry of Education and Research in Germany and the Deutsche Forschungsgemeinschaft (DFG, German Research Foundation)

References

[1] Rosenbaum, M., Aulenta, F., Villano, M., Angenent, L.T., 2011. Cathodes as electron donors for microbial metabolism: Which extracellular electron transfer mechanisms are involved? *Bioresource Technology*, 102: 324-333

Metal-free activated biochar as an oxygen reduction reaction catalyst in single chamber microbial fuel cells

Tommy Pepè Sciarria ¹, Maida Aysla Costa de Oliveira ², Barbara Mecheri ²,
Alessandra D'Epifanio ², Jillian L. Goldfarb ³, Fabrizio Adani ^{1,*}

¹ Università degli Studi di Milano-DISAA, Gruppo ricicla lab., Via Celoria 2, 20133 Milano, Italy.

² Department of Chemical Science and Technologies, University of Rome Tor Vergata, Via della Ricerca Scientifica, 00133, Italy ³

*Email: tommy.pepe@unimi.it

Metal-free catalysts are promising candidates for Bio-electrochemical Systems (BESs) due to their high surface area, chemical stability, good electrical conductivity, and enhanced mass-transport capabilities. In this study, biochars derived from olive mill waste (OMW) with and without supercritical CO₂ pretreatment, and salted pistachio nut shells, were produced via pyrolysis and/or chemical and physical activation. The catalytic activity towards oxygen reduction reactions (ORR) of the biochars was investigated by cyclic and linear sweep voltammetry in neutral media. The electrochemical characterization of the samples revealed that olive mill waste biochar showed the highest catalytic activity toward ORR, in terms of reaction rate (E_{pr} V vs. RHE = 0.537 ± 0.00), density of active sites, and number of electrons exchanged (n_e - $E_{0'}$ -0.6 V vs. RHE = 3.9 ± 0.2). These biochars were used as catalysts in air cathode microbial fuel cells. The power density obtained by MFCs equipped with an OMW cathode achieved a maximum power density of 271 ± 34 mWm⁻² (R_{ext} = 250 Ω) (Fig.1). This value was approximately 15 times higher than the power density obtained by a commercial carbon black used as control.

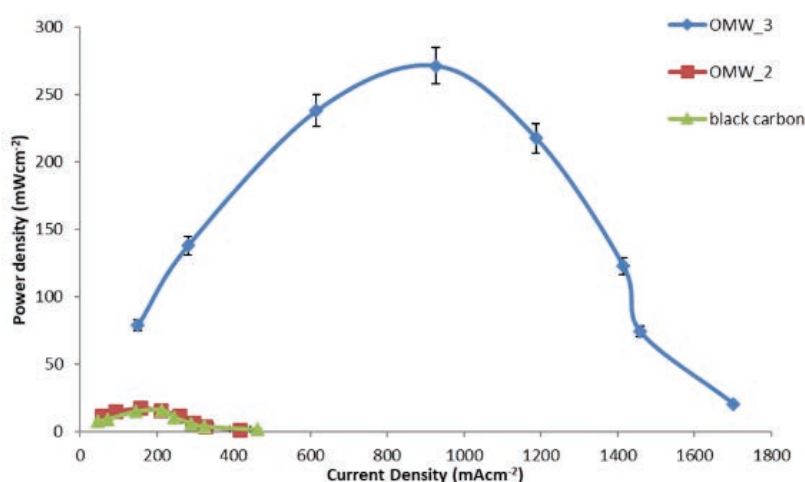

Figure 1: Comparison between power curves obtained by the different MFCs biochars reactors tested

Keywords: Olive mill waste; pistachio nutshell; biochar; activated carbon; Oxygen reduction reaction; Microbial fuel cell.

Towards improving the performance of microbial fuel cells: evaluation of inoculation strategies and anode materials

Zainab Ul*, Pilar Sánchez-Peña, Juan Antonio Baeza, Albert Guisasola

GENOCOV: Department d'Enginyeria Química, Biològica i Ambiental, Escola d'Enginyeria, Universitat Autònoma de Barcelona, Cerdanyola del Vallès, Spain

*Email : Zainab.Ul@uab.cat

The anode material of MFCs is crucial because its characteristics directly affect the performance of electron transfer from the bacteria to the anode. Different carbonaceous anode materials with favourable properties (carbon brush, carbon granules, thicker carbon felt (CF1), high conductivity carbon felt (CF2) and high-active-area carbon felt (CF3)) were tested in this work. Each material was fully characterized by employing different electrochemical techniques. MFC performance was studied using inoculation strategies of A) fixed 10 Ω external resistance (ER) and B) fixed anode potential (FAP) of 200 mV.

During the inoculation period, a slightly reduced start-up time and an earlier maximum current was observed for each anode using FAP. CF1 and CF2 exhibited higher maximum current with FAP. In the case of CF1, the MFC with FAP needed 33 days to get a similar current output, which was 12 days faster than the MFC operated with ER.

The full presentation will provide a comprehensive discussion on the performance and electrochemical parameters for each cell. For instance, a higher coulombic efficiency was obtained when operating with FAP. Out of five anode materials, the carbon brush yielded the highest maximum current output of 7 mA with a maximum coulombic efficiency of 85 %.

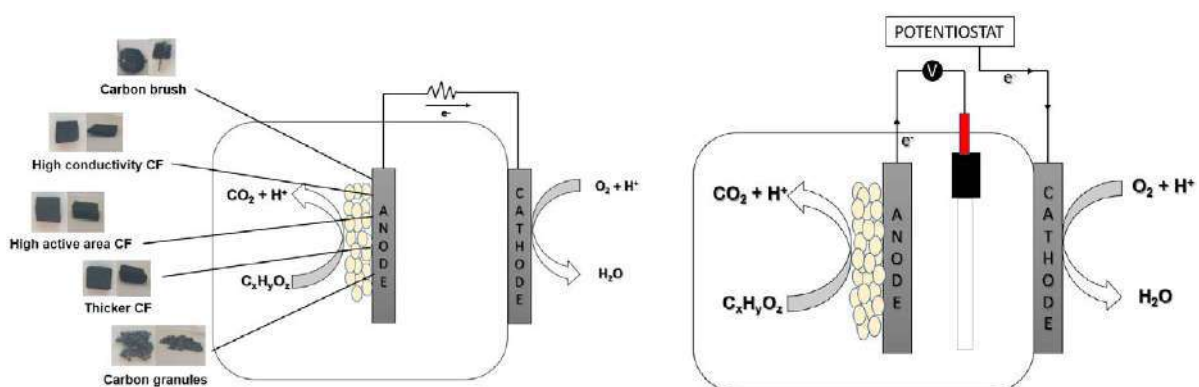

Fig. 1 Schematic diagram of MFCs with different anode materials using (A) external resistance and (B) fixed anode potential.

Keywords: Carbon-based anode materials, microbial fuel cells, fixed anode potential, anode, start-up time.

Funding: This work was supported by the Spanish Ministerio de Economía y Competitividad (CTQ2017-82404-R) with funds from the Fondo Europeo de Desarrollo Regional (FEDER). The authors are members of the GENOCOV research group (Grup de Recerca Consolidat de la Generalitat de Catalunya, 2017 SGR 1175, www.genocov.com).

Exploration of the reactivity of multiheme cytochromes and how it can be improved for (bio)electrocatalysis

Fonseca BM¹, Alves MA¹, Trindade IB¹, Silva L¹, Costa N¹, Moe E¹, Matias PM^{1,2}, Tien M³, Paquete CM¹, Louro RO^{1*}

¹ ITQB-NOVA, Av da República (EAN), 2780-157 Oeiras, Portugal

² IBET, Av da República (EAN), 2780-157 Oeiras, Portugal

³PENN state University, University Park, PA 16802, USA

*Email: louro@itqb.unl.pt

Extracellular electron transfer is a metabolism of microorganisms that can be interfaced with electrical circuits and therefore drive microbial electrochemical technologies. Multiheme cytochromes c are key players in this process. One of the most studied bacteria capable of extracellular electron transfer is *Shewanella oneidensis* MR-1. In this Gram-negative bacterium, electron transfer across the periplasmic space is dominated by the small tetraheme cytochrome c (STC) and flavocytochrome c [1]. Here, we explore the range of properties of STC that are compatible with physiological activity in *Shewanella*, and whether its functional and structural properties are optimized for electron transfer across the periplasmic space.

Our results show that a broad range of redox properties are compatible with physiological fitness as shown by the diversity of order of reduction potentials of the four hemes in STC from different organisms [2]. Our results also show that STC is not optimized for maximum rate of electron transfer. A single amino acid mutation was capable of increasing both the reduction and the oxidation rates by three fold [3].

Overall, these results provide good perspectives for manipulating multiheme cytochromes for improved performance either of their hosting organisms in microbial electrochemical technologies or as redox catalysts themselves.

Keywords: *Shewanella*, cytochromes, reduction potentials, redox kinetics, binding affinity

Funding: Financial support was provided by European EC Horizon2020 TIMB3 (Project 810856). This work was funded by national funds through FCT– Fundação para a Ciência e a Tecnologia, I.P. (FCT), Project MOSTMICRO-ITQB with refs UIDB/04612/2020 and UIDP/04612/2020. The NMR data were acquired at CERMAX, ITQB-NOVA, Oeiras, Portugal with equipment funded by FCT, project AAC 01/SAICT/2016. IBT and GH are financially supported by national funds through the FCT PT-NMR PhD Program via PD/BD/135187/2017

References

- [1] Fonseca BM, et al. Mind the gap: cytochrome interactions reveal electron pathways across the periplasm of *Shewanella oneidensis* MR-1, *Biochem J*, 449, 101-108 (2013) DOI:10.1042/BJ20121467
- [2] Fonseca BM, et al., Optimizing electroactive organisms: the effect of orthologous proteins, *Frontiers in Energy Research* (2019) 7, DOI: 10.3389/fenrg.2019.00002
- [3] Alves MA, et al, Modulation of the reactivity of multiheme cytochromes by site-directed mutagenesis: moving towards the optimization of microbial electrochemical technologies, *J Biol Inorg Chem*, 22, 87-97 (2017) DOI: 10.1007/s00775-016-1409-0

La persistència de l'entropia: Measuring the microbial electrochemical Peltier heat of different electrode materials

Benjamin Korth^{1,*}, Thomas Maskow¹, Matthias Schmidt², Falk Harnisch^{1,*}

¹ Department of Environmental Microbiology, Helmholtz Centre for Environmental Research - UFZ,

Permoser Str. 15, 04318 Leipzig, Germany

² Department of Isotope Biogeochemistry, Helmholtz Centre for Environmental Research - UFZ,

Permoser Str. 15, 04318 Leipzig, Germany

*Email: benjamin.korth@ufz.de, falk.harnisch@ufz.de

Although electroactive microorganisms (EAM) attracted considerable interests over the last two decades, their thermodynamic characterization, i.e., an analysis of the efficiency of the energy converting reactions, is still in its infancy. However, assessing the metabolic energy efficiencies and the energy fluxes during extracellular electron transfer (EET) are prerequisites for deciphering their ecological role and for estimating their biotechnological potential.

Biocalorimetry allows a thermodynamic characterizations of microbial systems by measuring its heat production. Based on a previously developed bioelectrocalorimeter¹, the heat and energy flows during cultivation of *Geobacter anodireducens* enrichment biofilms at gold, silver, and copper electrodes were analysed. By performing redox titration experiments, the respective microbial electrochemical Peltier heats (mePh) were derived. The mePh is an entropic effect at the cytochrome/solid electron acceptor interface during direct EET and represents a metabolic trade-off, as it decreases biomass yield but provides thermodynamic driving force for growth.

The experiments show that the mePh of all tested metal are substantially lower compared to graphite electrodes suggesting increased biomass yields of *Geobacter* biofilms at metal electrodes. The electrodes were analysed with scanning electron microscopy coupled with energy dispersive X-ray spectroscopy to characterize the elemental composition of electrode surfaces and to visualize the biofilms formed thereon.

Keywords: *Geobacter* biofilms, bioelectrocalorimetry, microbial electrochemical Peltier heat, metabolic energy efficiency, metal electrodes

Funding: This work was supported by the Helmholtz-Association in the frame of the Integration Platform "Tapping nature's potential for sustainable production and a healthy environment" at the UFZ.

References

(1) Korth, B.; Maskow, T.; Picioreanu, C.; Harnisch, F. The Microbial Electrochemical Peltier Heat: An Energetic Burden and Engineering Chance for Primary Microbial Electrochemical Technologies. *Energy Environ. Sci.* **2016**, *9* (8), 2539–2544. <https://doi.org/10.1039/C6EE01428C>.

Role of phenazine-enzyme physiology for current generation in a bioelectrochemical system

Anthony Chukwubuikem^{1,2}, Ahmed Mady¹, Carola Berger¹ and Miriam A. Rosenbaum^{1,2*}

1 Bio Pilot Plant, Leibniz Institute of Natural Product Research and Infection Biology – Hans-Knöll-Institute (HKI), Jena, Germany

2 Faculty of Biological Sciences, Friedrich Schiller University Jena

*Email: miriam.rosenbaum@leibniz-hki.de

Phenazine natural mediators which are mainly produced by *Pseudomonas aeruginosa* are employed to shuttle electrons to the anode of a bioelectrochemical system (BES). The challenges however in exploiting the full potential of these compounds in mediated extracellular electron transfer (MET) are: 1) that the molecular pathways of phenazine reduction are not clarified; 2) electron mediation using phenazines is substrate dependent, and 3) only a small share of electrons is able to be mediated to the anode.

We addressed these concerns by looking out for periplasmic enzymes that reduce phenazines since we argued that phenazine reduction are favored by substrate oxidation occurring in this part of the cell as compared to the cytoplasm.

We found out that the periplasmic glucose dehydrogenase (Gcd) is able to reduce phenazines *in vitro* and that improved current was generated in the BES by engineering the over-expression of this enzyme. To confirm phenazine uptake into the cytoplasm, we developed two molecular biosensors, which can detect the presence of different phenazine variants inside the cell.

These findings therefore give a clearer picture of the molecular mechanism of MET.

Keywords: Phenazines, mediated electron transfer, bioelectrochemical system, *Pseudomonas*

References

- Bosire E, et al. 'Strain- and Substrate-Dependent Redox Mediator and Electricity Production by *Pseudomonas aeruginosa*' *Applied and Environmental Microbiology*, 2016, 82: 5026.
Chukwubuikem A, Role of phenazine-enzyme physiology for current generation in a bioelectrochemical system *Microbial Biotechnology*, 2021. <https://doi.org/10.1111/1751-7915.13827>

Degustació de pernil a diferent voltatge de l'ànode: The influence of the anode potential on single cell yield coefficients of *Geobacter sulfurreducens*

Francesco Scarabotti¹, Laura Rago¹, Katja Bühler², Falk Harnisch^{1*}

¹Helmholtz Centre for Environmental Research GmbH - UFZ, Department of Environmental Microbiology, - 04318 Leipzig, Germany

²Helmholtz Centre for Environmental Research GmbH - UFZ, Department Solar Materials, - 04318 Leipzig, Germany

*Email: falk.harnisch@ufz.de

Geobacter sulfurreducens is the model organism for direct extracellular electron transfer (EET). Although several details of the molecular mechanisms of EET are deciphered [1,2], there is still a significant lack of knowledge (e.g. kinetics, yields). Here we provide information about the influence of the anode potential on coefficients at single cell level, i.e. the moles of electrons transferred to the anode, per replication for early-stage biofilm electrodes. This information is highly relevant for physiological as well as technical considerations and not known yet for *Geobacter* growing at anodes [3]. Therefore, single and double chamber BES were operated in batch mode using as anode material i) the standard graphite and ii) a microscopy slide sputter-coated with 10 nm of Chromium (Cr) and 25 nm of Gold Palladium (AuPd) enabling the analysis of the biofilms with CLSM.

We demonstrate that the anodic potential has a strong influence on the kinetics of growth as well as on the number of electrons transferred for replication, but does not influence other parameters like formal potential (E_p) of the EET and coulombic efficiencies (CE). Like in ham degustation, where the taste is used for choosing the best ham, here the anode material and potential are used.

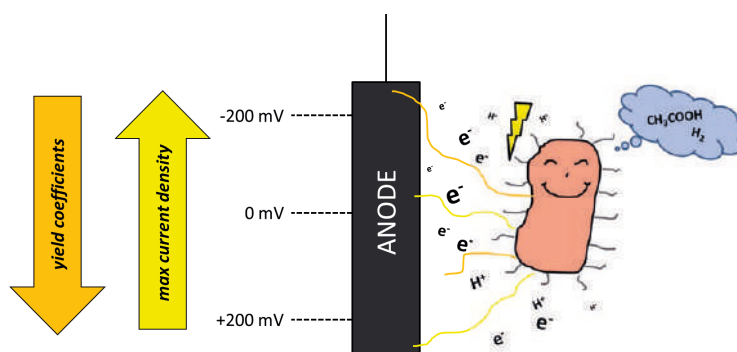

Keywords: electroactive microorganisms, extracellular electron transfer, anode potential, yield coefficients.

Funding: This work was supported by the Helmholtz-Association in the frame of the Integration Platform "Tapping nature's potential for sustainable production and a healthy environment" at the UFZ.

References

- [1] D.R. Lovley, Electromicrobiology, Annual Review of Microbiology. 66 (2012) 391–409. <https://doi.org/10.1146/annurev-micro-092611-150104>.
- [2] S.V. Mohan, S. Varjani, A. Pandey, (Eds.) Microbial electrochemical technology: sustainable platform for fuels, chemicals and

remediation, 2018, ELSEVIER.

- [3] F. Scarabotti, L. Rago, K. Bühler, F. Harnisch, The electrode potential determines the yield coefficients of early-stage *Geobacter sulfurreducens* biofilm anodes, Bioelectrochemistry. 140 (2021) 107752. <https://doi.org/10.1016/j.bioelechem.2021.107752>.

In situ and non-destructive real time microscopic investigation of multi-species electroactive biofilms on transparent microfluidic BES

Lucila Martínez Ostormujof¹, Sébastien Teychené¹, Benjamin Erable¹

¹ Laboratoire de Génie Chimique, Université de Toulouse, France

4 allée Emile Monso – CS 44362 – 31030 Toulouse Cedex 4

*Email: lucila.marinezostormujof@toulouse-inp.fr

Our research interest is focused on improving the durability of multi-species microbial anodes in BES. A large number of studies have indeed documented anodic current densities that are limited or drop after a few days or tens of days of operation [1,2,3]. Identifying what occurs at the anode-biofilm interface, from the attachment of the pioneer bacteria and during the colonisation and maturation of the biofilm on the anode, might provide novel explanations for the decrease of EABs electrochemical activity. To this end, our original approach of local investigation combines microfluidic technologies, electroanalysis and real-time microscopy to focus the exploration at the micrometer scale surface of stainless steel microelectrodes. A transparent microfluidic BES was developed using ITO conductive glass and stainless steel microwire as electrodes. This design allows non-invasive and real-time investigation of local phenomena such as bacterial adhesion, cells mobility and biofilm growth by simultaneous electrode polarization, hydrodynamics and electrolyte composition (pH, substrate load) control. This approach is further complemented by more conventional destructive analyses (microbial community, cell viability, EPS composition) to link bacterial and bioelectrochemical dynamics of the biofilm. We have identified that bacterial cells require a growth state in order to express high electroactivity

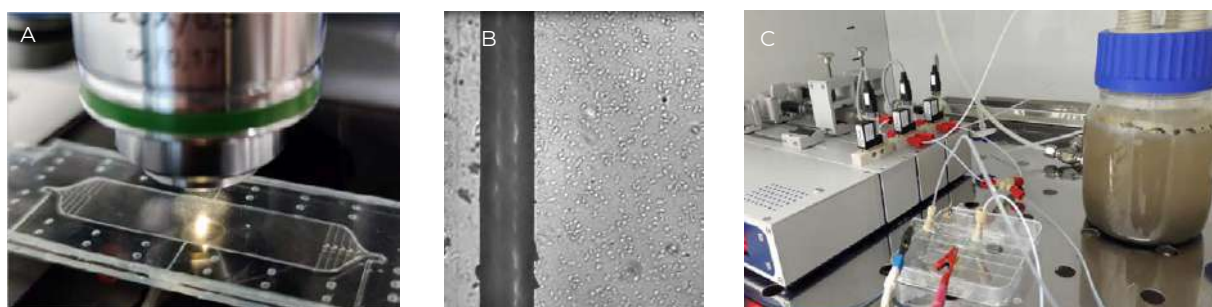

Fig. 1 (A, B) Real-time microscopic monitoring of the anode of a microBES colonized by multi-species EAB. (C) Experimental platform for the formation of multi-species EABs at the microfluidic BES.

Keywords: Electroactive biofilms, Stainless steel and platinum micro-

electrodes, Real-time microscopy, Microfluidic cells, Bioelectrochemical systems

Funding: Projet-ANR-18-CE05-0024

References

[1] P. Chong et al., International Jour-

nal of Hydrogen Energy. ISSN 0360-3199 (2018)

[2] J. Madjarov et al., Bioresour. Technol., vol 221, pp.165-171 (2016)

[3] B. Cercado-Quezada et al., Electrochem. commun., vol 13, no. 5, pp. 440–443 (2011)

Magnetic resonance imaging as a tool for the analysis and optimization of electroactive biofilms inside porous electrode structures

Luca Häuser*¹, Johannes Erben¹, Guillaume Pillot¹, Sven Kerzenmacher¹, Wolfgang Dreher² and Ekkehard Küstermann²

¹ Center for Environmental Research and Sustainable Technology (UFT), University of Bremen, 28359 Bremen, Germany

² In-vivo-MR Group, Faculty 02 (Biology/Chemistry), University of Bremen, 28359 Bremen, Germany

*Email: kerzenmacher@uni-bremen.de

Information about the morphology of the electroactive biofilms and the occurring transport phenomena is required to obtain a deeper understanding of limiting processes and develop improved electrode materials. Magnetic Resonance Imaging (MRI) enables the spatially resolved measurement of biofilm distribution and transport characteristics, even inside optically opaque porous electrode materials.

We present an MRI compatible reactor for the *in vivo*, *in situ* and *in operando* analysis of electroactive biofilms on a macro- and mesoscale (down to 50 μm). In detail we depicted electroactive model biofilms of *Shewanella oneidensis* MR-1 inside electrospun nanofiber electrodes. The structure and the transport phenomena are analyzed in terms of relative transversal relaxation times T_2 and relative apparent diffusion coefficients ADC, both normalized to their value in the bulk medium. Inside the biofilm, T_2 as well as ADC were found to be lower than in the medium.

In the future we will use MRI to quantify the biofilm density distribution, the occurring transport phenomena, and the metabolic changes of concentrations of nutrients and products. The acquired data can be used to develop accurate models of electroactive biofilms and may serve to tailor electrode materials.

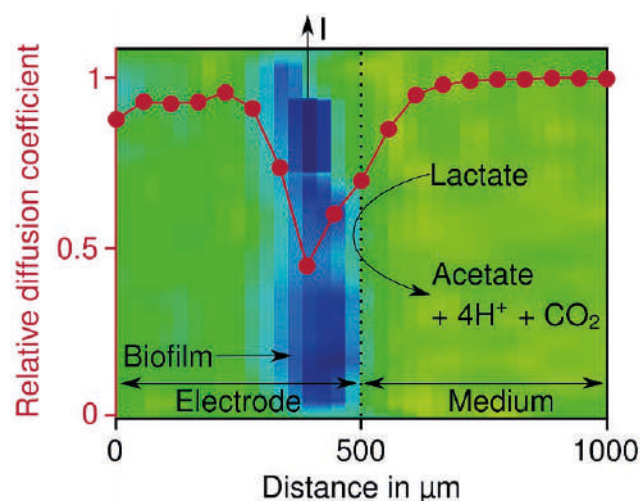

Fig. 1: Graphical abstract: Morphology of the biofilm and diffusion coefficients can be spatially obtained by MRI inside a porous electrode. The biofilm colonizes the medium facing fraction of the electrode and thus diffusion is hampered.

Keywords: Electroactive biofilm, porous electrode, magnetic resonance imaging, diffusion coefficient, biofilm structure.

Influence of different photocatalytic dopants in the antifouling performance of Nanofiltration Microbial fuel cells

**Raúl Bahamonde Soria^{1,2}, Patricia Luis²,
Corresponding Author^{1*}**

¹ Institution: Address Postal code Materials & Process Engineering (iMMC-IMAP), Université catholique de Louvain, Place Sainte Barbe 2, 1348 Louvain-la-Neuve, Belgium

² Department of Renewable Energies, Faculty of Chemical Sciences, Central University of Ecuador, University Avenue, Quito 170129, Ecuador. (rabahamonde@uce.edu.ec)

*Email: rabahamonde@uce.edu.ec

Microbial fuel cells (MFCs) have been considered as a promising candidate to tackle the contradiction between effluent treatment and energy conservation [1]. The high cost of some materials, such as membranes, has led researchers to explore alternatives. The use of ultrafiltration (UF), direct osmosis (FO) membranes has provided interesting alternatives. With pore diameters between 10 and 100 Å, NF membranes lie in a transition region between UF and FO. To our knowledge, NF membranes have never been tested in MFCs and could be considered interesting candidates [2].

Moreover, fouling of the membranes also presents a problem in all configurations. For this purpose, nature-inspired modifications using polydopamine (PDA) [3] or semiconductors such as TiO₂ and ZnO provide the membrane capabilities to oxidize organic matter that tries to adhere to the surface, which provides self-cleaning and antifouling performances.

The present work compared the benefits of bio-inspired modification of commercial membranes with PDA and TiO₂, ZnO nanoparticles, as well as the development of a ZnO photocatalyst doped with Al³⁺ and Er³⁺ to enhance visible light absorption, favoring the antifouling performance of these Nanofiltration MFC systems.

Keywords: antifouling, nanofiltration, microbial fuel cells, membranes.

Funding: (ARES) (RFCQ-CQ-SO13-186-2017)

References

- [1] Xu Z, et al. J Power Sources 2021; 501: 230000.
- [2] Olliot M, et al. Appl Energy 2016;183:1682–704.
- [3] Bahamonde Soria R, et al. Sep. Purif. Technol 2020; 251:117280

Development and application of conductive nanomaterials for bioelectrochemical denitrification

**Magda Nechanická¹, Elisabet Perona-Vico², Karel Havlíček¹,
Narcís Pous³, Sebastià Puig³, Lukáš Dvořák¹, Lluís Bañeras^{2,*}**

¹ Institute for Nanomaterials, Advanced Technology and Innovation,
Technical University of Liberec, Studentská 1402/2, 460 01 Liberec, Czech
Republic

² Molecular Microbial Ecology Group, Institute of Aquatic Ecology
(University of Girona), Maria Aurèlia Capmany 40, 17003 Girona, Spain

³ LEQUiA, Institute of the Environment (University of Girona), Maria
Aurèlia Capmany 69, 17003 Girona, Spain

*Email lluis.banyeras@udg.edu

Conductive nanomaterials have gained immense interest because of their distinctive properties and their potential in numerous fields. A relevant example is their potential use as electrodes in hybrid systems of biotechnology and electrochemistry, such as bioelectrochemical systems (BES). Within this work, different approaches for conductive nanostructure preparation were employed. Electrostatic spinning (Nanospider™) was used as a method for nanofiber preparation. Polypyrrole, polyaniline, Fe₃O₄ nanoparticles and aluminium were selected as conducting components for nanostructures. Nine nanomaterials were prepared and characterized by scanning electron microscopy and electrical resistance measurements. However, only three of them were able to transfer electrical current. Conductive nanomaterials were further tested as a support for electroactive denitrifying bacteria in lab-scale single cell BES reactors. The performance of the reactors with tested nanostructured electrodes was evaluated in terms of nitrate removal and bioelectrochemical activity (chronoamperometry and cyclic voltammetry), and compared to commonly used electrode materials such as carbon cloth and graphite rod. Denitrifiers were selectively enriched depending on the material used. A gradual decrease of nitrate concentration was observed when PVB nanofibers with polyaniline or polypyrrole were used as electrodes. These conductive nanomaterials have shown potential for biological removal of nitrate in low organic-content water using BES reactors.

Keywords: conductive nanomaterials, cyclic voltammetry, denitrification, microbiome selection

Funding: This work was supported by the European Union's Horizon 2020 project ELECTRA (no. 826244).

The role of bioanode-membrane interlayer in tubular Ceramic Microbial Fuel Cells (CMFCs)

Rodríguez J.¹, Campana R.¹, Palmas S.², Mais L.², Sevilla G.¹

¹ Centro Nacional del Hidrógeno, Puertollano, 13500, Spain

² Università degli studi di Cagliari, Dipartimento di Ingegneria Meccanica, Chimica e Dei Materiali, Cagliari, 09123, Italy

*Email: jesus.rodriquez@cnh2.es

CMFCs are an interesting alternative to conventional systems, as they replace polymeric membranes with low-cost and sustainable ceramic materials. However, their development requires the optimization of some aspects such as the ohmic overpotentials associated with the membrane and the contact between components. Although, in the case of cathodes, the use of conductive carbon inks is common for improving the membrane-cathode electrical contact [1], their application in bioanodes has hardly been investigated.

In the present work, the influence of a conductive interlayer at the interface between ceramic membrane and bioanode is analyzed in tubular CMFCs. The deposition of the interlayer on the ceramic membrane was carried out by advanced ceramic processing techniques, identifying the optimal electrical and morphological conditions of the layer. Three designs of CMFCs were studied (fig. 1): carbon felt bioanode directly in contact with the ceramic membrane (MFC1); interlayer acting as anode (MFC2); bioanode and membrane connected by interlayer (MFC3, not shown). Moreover, MFC2 represents a new “one piece” configuration CMFC.

Electrochemical techniques allowed to evaluate the role of the interlayer in resistive terms. In addition, a morphological study of the different bioanodes will be carried out by SEM, paying attention to the membrane-bioanode interface and the biofilm formed.

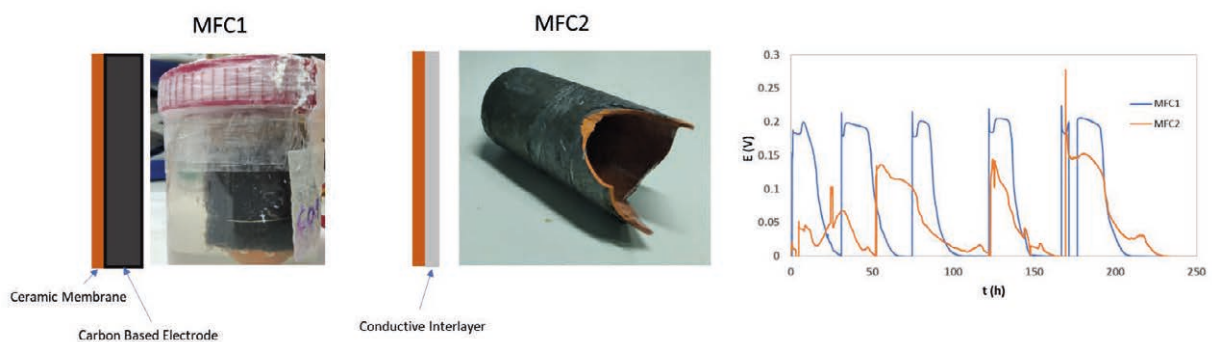

Fig. 1 Left: A) MFC 1 Design B) MFC2 Design C) Potential versus time response for MFC1 and MFC2

Keywords: Ceramic-MFC, Bioanode-Membrane Interlayer, “one piece” configuration.

References

[1] Salar-García MJ, et al. Microalgae as substrate in low cost terracotta-based microbial fuel cells: novel application of the catholyte produced. *Bioresource technology*, 2016, 209: 380

Development and upscaling of gas diffusion electrodes for wastewater treatment and electrosynthesis of chemicals

Deepak Pant^{1*}, Yuvraj Birdja¹, Metin Bulut¹, Jan Vaes¹

Separation & Conversion Technology, Flemish Institute for Technological Research (VITO), Boeretang 200, 2400 Mol, Belgium

*Email: deepak.pant@vito.be

Technologies related to gas diffusion electrodes (GDEs) offer solutions for gaseous reagents taking part in electrochemical reactions. (Bio)electrochemical processes suffer from challenges like high costs of platinized electrodes¹; rapid catalyst degradation and low performance due to non-uniform electrode quality²; difficulties in upscaling. Scaling up microbial fuel cells (MFCs) requires use of large electrodes which are often difficult to fabricate without loss in quality. VITO has developed GDEs tailored for systems with aqueous electrolytes and a gas-water interface, which are characterized by controllable pore diameters in the polymer-bound active layer, mechanical robustness and low water permeability². These cold-rolled (VITOCORE[®]) and phase-inversion based (VITO CASE[®]) electrodes enable reproducible quality in sizes from 10 cm² to 1 m². Large-scale VITOCORE[®] air cathodes were recently developed and tested in 85 L and 255 L MFCs to evaluate the impact of the cathode size on MFC performance^{4,5}. For CO₂ electroreduction, GDEs based on Sn, Cu and Pd were developed and evaluated for production of formic acid and oxalic acid.

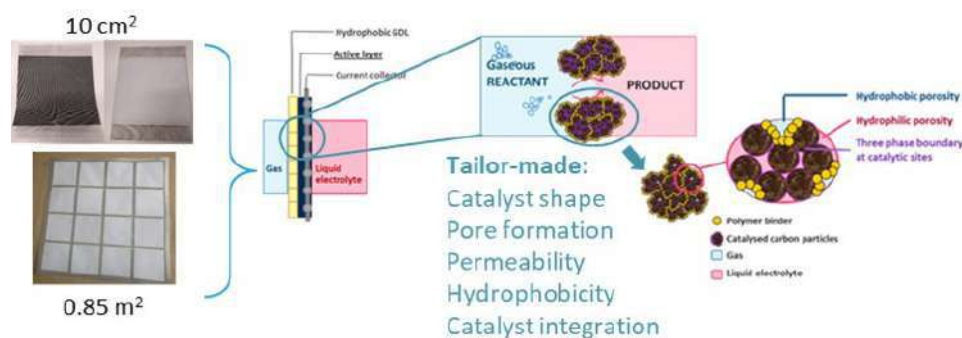

Fig. 1. VITO CORE[®] GDEs as air cathodes

Keywords: Gas diffusion electrodes, microbial fuel cells, microbial electrosynthesis, resource recovery, CO₂ electroreduction

Funding: E2C Project (Interreg), Bac-To-Fuel Project (Horizon 2020)

References

- [1] Sharma et al., Electrode material properties for designing effective microbial electrosynthesis systems. *J. Materials Chemistry A*, 2019, 7(42), 24420.
- [2] Alvarez-Gallego et al., Development of gas diffusion electrodes for cogeneration of chemicals and electricity *Electrochim. Acta* 2012, 82, 415.
- [3] Gutiérrez Sánchez et al., Recent advances in industrial CO₂ electroreduction. *Curr. Opin. Green*

Sustain. Chem., 2019, 16, 47.

[4] Rossi et al., Evaluating a multi-panel air cathode through electrochemical and biotic tests. *Wat. Res.*, 2019, 148, 51.

[5] Hiegemann et al., Performance and inorganic fouling of a submergible 255 L prototype microbial fuel cell module during continuous long-term operation with real municipal wastewater under practical conditions. *Biores. Technol.*, 2019, 294, 122227.

Capacitive bioanodes in fixed and moving bed reactors

Tom Sleutels^{1*}, Casper Borsje^{1,2}, Annemiek Ter Heijne², Cees Buisman^{1,2}

¹ Wetsus, European Centre of Excellence for Sustainable Water Technology, 8900 CC, Leeuwarden, The Netherlands

² Environmental Technology, Wageningen University & Research, Bornse Weilanden 9, 6708 WG Wageningen, The Netherlands

*Email: tom.sleutels@wetsus.nl

Capacitive bioanodes can be used to improve current production in microbial electrochemical systems. Here, we studied the use of activated carbon as capacitive bioanodes in fixed and moving bed reactors. In a fixed bed reactor, most capacitive charge was recovered from the current collector closest to the membrane. Increasing bed thickness from 5 mm to 10 mm resulted in a 1.6 times higher current density per membrane area. These findings were used to improve the design of a moving bed reactor, where activated carbon granules with electro-active biofilm moved through a discharge cell and were recirculated using a gas lift. This moving bed bioanode produced a current of 43 A/m².

Discharge properties were further studied in abiotic experiments. Capacitive discharging was improved most by changes in potential difference between current collector and charged granules (ΔE 0.3 and 0.5 V). Discharging from both sides of the granular bed, as compared to discharging from one side, increased the transferred charge, irrespective of increasing the electrolyte conductivity. This showed that electrical resistance was more important in determining the transferred charge than ionic resistance. Analysis of the discharging process showed that discharging increased the local conductivity through the release of ions from the granules.

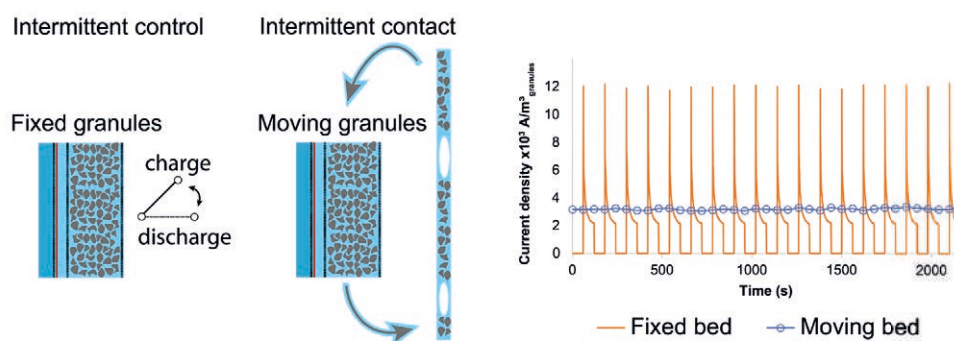

Fig. 1 The discharge behaviour of capacitive granular bioanodes was tested in fixed and moving bed reactors

Keywords: Capacitive bioanodes, moving bed, fixed bed

Graphene functionalization with metallic Pt nanoparticles: envisaging future cathodes for bioelectrochemical H₂ production

**Pilar Sánchez-Peña^{1*}, Jordi Rodríguez², David Gabriel¹,
Juan Antonio Baeza¹, Albert Guisasola¹, Mireia Baeza²**

¹GENOCOV, Departament d'Enginyeria Química, Biològica i Ambiental, Escola d'Enginyeria, Universitat Autònoma de Barcelona, Cerdanyola del Vallès, Spain

²GENOCOV, Departament Química, Facultat de Ciències, Universitat Autònoma de Barcelona, Cerdanyola del Vallès, Spain

*Email: pilar.sanchez.pena@uab.cat

Platinum (Pt) is one of the most widely used catalysts in Microbial Electrolysis Cells (MEC) to overcome the relatively slow kinetics of hydrogen evolution. Pt is commonly applied as a commercial ink (90 % carbon/10 % Pt) [1], but this strategy is not economically feasible at large scale.

This work describes the development, application, characterisation, and optimisation of two novel inks with novel carbon materials functionalised with Pt: reduced graphene oxide (Pt@rGO) and graphitene (Pt@Graphitene). These materials showed better performance by increasing the catalytic effect over conventional inks, reaching a peak of the current density of ca. 0.8 A/m². This is almost double the average value using the same cell and commercial ink [2].

The percentage of Pt functionalization was higher than similar works: almost 20 %. The full presentation will show a comprehensive characterisation of both materials with optical (scanning electron microscopy and inductively coupled plasma mass spectrometry) and electrochemical (cyclic voltammetry and impedance) techniques.

For instance, the electroactive area was 1.14 cm² for Pt@rGO and 0.69 cm² for Pt@Graphitene and the surface area measured were 10.76 m²/g for Pt@Graphitene and 24.40 m²/g for Pt@rGO. These values are twice the surface area values of same materials without functionalization.

Graphene functionalization with metallic Pt nanoparticles: envisaging future cathodes for bioelectrochemical H₂ production

Fig. 1 SEM images of different materials. Pt@rGO (a) and Pt@Graphitene (b).

Keywords: Platinum, Reduced graphene oxide, Graphitene, Single-chamber membrane-less microbial electrolysis cell

Funding: FI predoctoral scholarship (2018FI_B01161) from the Catalan Government (Agencia de Gestio d'Ajuts Universitaris i de Recerca). This work was supported by the Spanish Ministerio de Economía y Competitividad (CTQ2014-60495-R, CTQ2017-82404-R) with funds from the Fondo Europeo de Desarrollo Regional (FEDER). The authors are members of the GENOCOV research group (Grup de Recerca Consolidat de la Generalitat de Catalunya, 2017 SGR 1175, www.genocov.com).

References

- [1] S. Cheng, H. Liu, and B. E. Logan, "Power densities using different cathode catalysts (Pt and CoTMPP) and polymer binders (Nafion and PTFE) in single chamber microbial fuel cells," *Environ. Sci. Technol.*, 206, vol. 40, no. 1, pp. 364–369.
- [2] E. D'enginyeria, Y. R. Franco, A. Guisasola, C. Juan, and A. B. Labat, "Scale-up opportunities of microbial electrolysis cells for hydrogen production from wastewater." 2015.

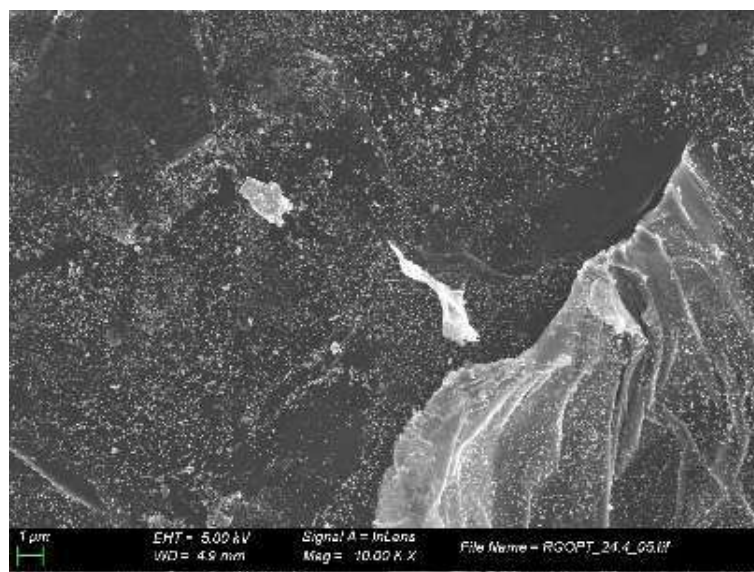
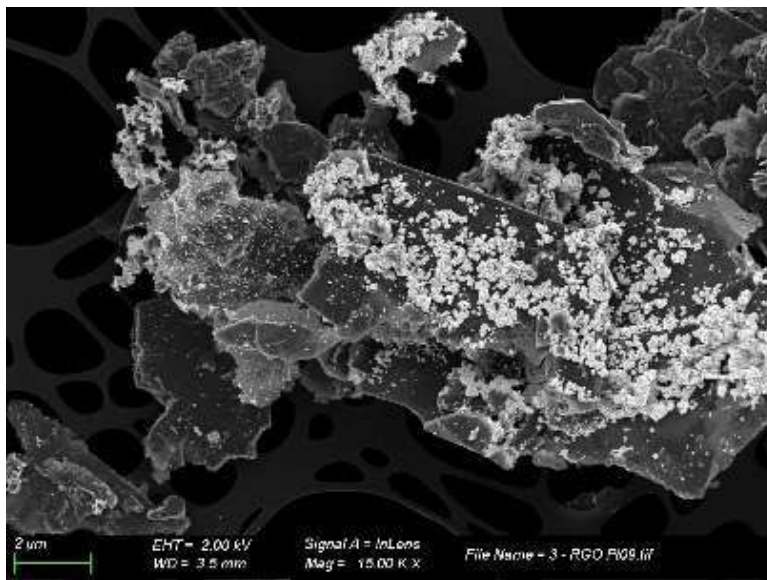

Estructures superficiales com les d'Antoni Gaudi: Platinized titanium as cost-effective anode material for Kolbe electrolysis

Katharina Neubert¹, Matthias Schmidt², Falk Harnisch^{1,*}

¹ Department of Environmental Microbiology, UFZ – Helmholtz-Centre for Environmental Research, Leipzig, Germany

² Department of Isotope Biogeochemistry, UFZ – Helmholtz-Centre for Environmental Research, Leipzig, Germany

*Email: falk.harnisch@ufz.de

A circular economy is based on linking the sector of electric power production and storage with the sector of production of chemicals and fuels [1]. This link can be created by the Kolbe electrolysis allowing the electrochemical conversion of medium chain carboxylic acids (MCCA) to *n*-alkanes [2]. Pure platinum is the archetype anode material for Kolbe electrolysis. Only few other materials were studied but are not commercially available and less efficient than monolithic Pt [3–7]. On industrial scale cheaper materials being available in large quantity are required.

Hence, the suitability of five electrode materials for the Kolbe electrolysis of *n*-hexanoic acid to *n*-decane was tested. Platinized titanium stood out with a Coulombic Efficiency (CE) of $93.1 \pm 6.7\%$ ($n=6$) for *n*-hexanoic acid degradation and $48.3 \pm 3.2\%$ ($n=6$) for *n*-decane production which is comparable to pure platinum ($89.7 \pm 14.4\%$ and $55.5 \pm 3.5\%$; $n=6$). An economical evaluation showed that platinized titanium requires >36 times less capex at only <10% increased opex. Using SEM coupled with EDX structure-function-relationships could be revealed, showing that 1-3% of uncovered surface already causes a ~50% decrease in CE. Thus, the degree of coverage with platinum plays the most important role when using platinized anodes.

Estructures superficiais com les d'Antoni Gaudi: Platinized titanium as cost-effective anode material for Kolbe electrolysis

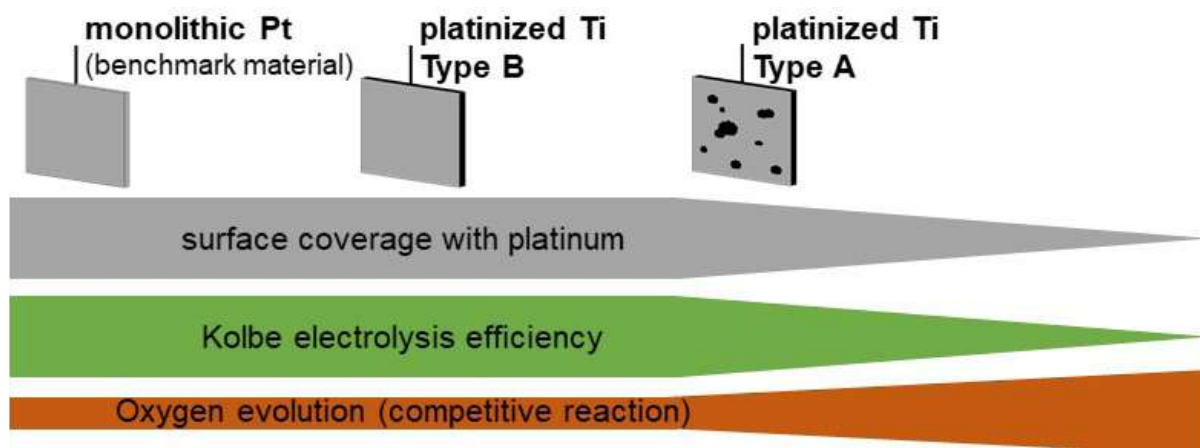

Fig. 1: Relationship between surface coverage, Kolbe electrolysis efficiency and oxygen evolution efficiency (competitive reaction) for the benchmark material monolithic platinum and two different platinized titanium materials.

Keywords: drop-in fuel, power-to-fuel, power-to-chemicals, electroorganic synthesis

Funding: This research is financed by the German Federal Ministry of Education and Research (BMBF) under the VIP+-project Molkekraft: Microbial-electrochemical exploitation of sour whey for the production of drop-in aviation fuel (Funding code: 03VP06911). This work was supported by the Helmholtz-Association in the frame of the Integration Platform "Tapping nature's potential for sustainable production and a healthy environment" at the UFZ. The authors are thankful for the use of the analytical facilities of the Centre for Chemical Microscopy (ProVIS) at UFZ Leipzig, which is supported by European Regional Development Funds (EFRE – Europe Funds Saxony) and the Helmholtz Association.

References

- [1] de Vasconcelos B.R., Lavoie J.M.. Recent advances in power-to-X technology for the production of fuels and chemicals. *Front. Chem.*, 2019, 7: 392.
- [2] Urban C., et al. Production of drop-in fuels from biomass at high selectivity by combined microbial and electrochemical conversion. *Energy Environ. Sci.*, 2017, 10: 2231-2244.
- [3] Stang C., Harnisch F.. The Dilemma of Supporting Electrolytes for Electroorganic Synthesis: A Case Study on Kolbe Electrolysis. *ChemSusChem*, 2016, 9: 50-60.
- [4] Urban C., Harnisch F.. Deterioration of Aqueous n-Octanoate Electrolysis with Electrolytic Conductivity Collapse Caused by the Formation of n-Octanoic Acid/n-Octanoate Agglomerates. *ChemElectroChem*, 2017, 4: 1378-1389.
- [5] Qiu Y., et al. Anodic electrocatalytic conversion of carboxylic acids on thin films of RuO₂, IrO₂, and Pt. *Appl. Catal. B Environ.*, 2020, 277: 119277
- [6] Wadhawan J.D., et al. Emulsion electrosynthesis in the presence of power ultrasound Biphasic Kolbe coupling processes at platinum and boron-doped diamond electrodes. *J. Electroanal. Chem.*, 2001, 507: 135-143.
- [7] Nilges P., et al. Electrochemistry for biofuel generation: Electrochemical conversion of levulinic acid to octane. *Energy Environ. Sci.*, 2012, 5: 5231-5235.

The applicability of the Maximum Power-point of Microbial Fuel Cells: Influence of Potential Scan rate and real-time external Load

Simeon M. I.^{1,2,*}, Freitag R.¹

¹ Universität Bayreuth, Universitätsstraße 30, 95447, Bayreuth Germany

² Federal University of Technology Minna, PMB 65, Minna, Nigeria

*Email: meshack.simeon@uni-bayreuth.de; s.imologie@futminna.edu.ng

Performance evaluation of a microbial fuel cell (MFC) is usually done with linear sweep voltammetry (LSV) [1] at a given potential scan rate (PSR) [2]. This evaluation does not often reflect the long-term performance of the MFC under real-time external loads [1]. In this study, the performance of a single-chamber MFC was evaluated with three external loads (1206, 470, and 270 Ohms) calculated from LSV maximum power point (MPP) with three PSRs (0.1, 0.5, and 1 mV/s). The estimated power from the MPP in ascending order of PSR were 61.96, 87.88, and 166.68 mW/m² at 116.5, 229.6 and 403 mA/m², respectively. The average power obtained with 1206, 470, and 270 Ohms in the first two hours of operation were 73 ± 16.7, 36.3 ± 42, and 88.5 ± 120.1 mW/m² at current densities of 124.6 ± 14.3, 121.2 ± 73.4, and 232.6 ± 176.2 mA/m², respectively. The result showed that overestimation was more pronounced at higher PSRs. Although the MFC was initially underestimated at 0.1 mV/s, this PSR more accurately reflects the true and applicable estimate of the long-term performance of the MFC. These results are explicitly beneficial for electrochemical estimation of the actual performance of MFCs under real-time external loads.

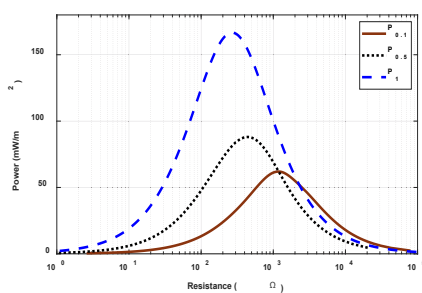

Fig. 1. Maximum power at different scan rates

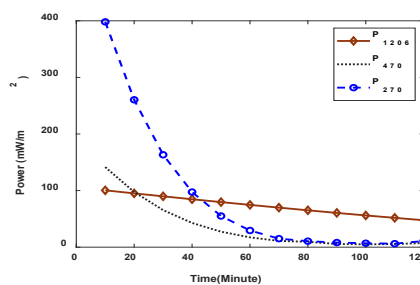

Fig. 2. Short-term performance at different external loads

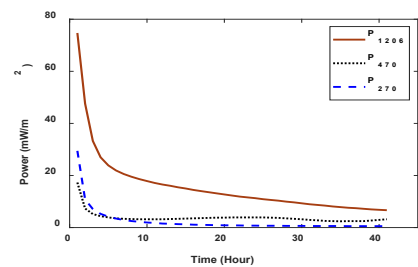

Fig. 3. long-term performance at different external loads

Keywords: maximum power, microbial fuel cell, external load, potential scan rate

Funding: Nigerian-German Postgraduate Training Programme PhD, 2018 (57401043)

References

[1] Watson & Logan. Analysis of polarization methods for elimination of power overshoot in microbial fuel cells. *Electrochemistry Communications*,

2011, 13: 54–56

[2] Zhao et al. Techniques for the study and development of microbial fuel cells: an electrochemical perspective. *Chem. Soc. Rev.*, 2009, 38: 1926–1939.

Power to Gas: newsworthy connection between electricity production trend, biochar electrodes and polarizations

Andrea Goglio^{1*}, Elisa Clagnan¹, Tommy Pepè Sciarria¹, Barbara Mecheri², Alessandra D' Epifanio², Jillian L. Goldfarb³, Fabrizio Adani¹

1 - Gruppo Ricicla Lab., Department of Agricultural and Environmental Science, University of Milan, Via Celoria 2, 20133, Italy

2 - Department of Chemical Science and Technologies, University of Rome Tor Vergata, Via della Ricerca Scientifica, 00133, Rome, Italy

3 - Department of Biological and Environmental Engineering, College of Agriculture and Life Sciences, Cornell University, Ithaca, NY, 14853, USA

*Email: andrea.goglio@unimi.it

In the near future, renewable electricity produced will be considered as primary sources of energy and its cost and sustainability will soon stably meet the grid parity. Electricity storage capacity will be the real challenge, to buffer intermittent productions and consumptions (Breyer and Gerlach, 2013). Nowadays also biomasses sourced from agricultural by-products have been touted as an important feedstock for the production of high-value materials, chemicals and fuels to promote a circular economy and zero-waste production (Walmsley et al. 2019). In other hands, the hydrogen production is taking an important place into the biofuels scenario. In this study, biochars derived from olive mill waste (OMW) with and without supercritical CO₂ pre-treatment are produced via pyrolysis and/or chemical and physical activation. Different activated biochars are used to manufacture electrodes for the hydrogen production by bioelectrochemical system (BES). The electrodes produced from different biochars are characterised by a series of physical, chemical and electrochemical measurements as the BET surface area (444 - 742 m² g⁻¹). In this experiment are tested 5 different electrodes (2 different OMW activated biochar, carbon black, black pearl and stainless steel mesh) at 2 different polarizations (600-800 mV vs Ag/AgCl reference electrode). The study aim is the increasing of the hydrogen and methane production from organic-rich wastewater, decreasing of the energy demand to generate the cathodic reaction thanks to the biochar electrodes.



Keywords: bioelectrochemical system, power to gas, hydrogen, methane, biochar

References

[1] Breyer, C., Gerlach, A., 2013. Global overview on grid-parity. *Prog. Photovolt Res. Appl.* 21, 121–136.

[2] T.G. Walmsley, H.Y.B. Ong, J.J. Klemes, R.R. Tan, P.S. Varbanov, Circular Integration of processes, industries, and economies, *Renew. Sustain. Energy Rev.* 107 (2019) 507–515.

Copla electroquímica: How sound is Electrochemical Impedance Spectroscopy on biofilm electrodes?

Jörg Kretzschmar^{1*}, Falk Harnisch²

¹DBFZ Deutsches Biomasseforschungszentrum (German Biomass Research Centre), Torgauer Straße 116, 04347 Leipzig, Germany

² Department of Environmental Microbiology, UFZ – Helmholtz-Centre for Environmental Research, Leipzig, Germany

*corresponding author: joerg.kretzschmar@dbfz.de

Electrochemical impedance spectroscopy (EIS) is a versatile tool to examine characteristics of electroactive biofilms that are not accessible by direct current measurements such as chronoamperometry or cyclic voltammetry [1]. Several studies show the determination of, e.g. biofilm resistance and biofilm capacitance [2-3]. However, EIS in microbial electrochemistry is sometimes applied superficially or evaluation of presented data is not comprehensive due to misinterpretation or missing data validation. This hinders a more widespread application of this powerful method, not only for determination of specific biofilm electrode parameters, but also - from a more practical perspective - as tool for in situ condition monitoring of biofilm electrodes.

With this contribution, we introduce basics of EIS on biofilm electrodes and discuss how the experimental setup, e.g. electrode material or magnetic stirrers can influence EIS data. Furthermore, we elaborate on the necessity of data validation as well as careful data interpretation using electrical equivalent circuit models. For the latter we differentiate in whitebox and greybox models that can lead to conclusive data and meaningful insights or applications of EIS on biofilm electrodes [4].

Keywords: microbial electrochemical technologies, electroactive microorganisms, exoelectrogens, alternating current.

Funding: JK gratefully acknowledges funding by the federal ministry of economic affairs and energy (project "Optimand", grant number 03KB115) as well as funding by the Wageningen Institute for Environment and Climate Research (grant number WIMEK 2018-098).

References

- [1] Yoho RA, Popat SC, Fabregat-Santiago F, Giménez S, ter Heijne A, Torres C. Electrochemical Impedance Spectroscopy as a Powerful Analytical Tool for the Study of Microbial Electrochemical Cells. *Biofilms in Bioelectrochemical Systems*: John Wiley & Sons, Inc; 2015, doi:10.1002/9781119097426.ch8
- [2] ter Heijne A, Schaetzle O, Gimenez S, Navarro L, Hamelers B, Fabregat-Santiago F. Analysis of bio-anode performance through electrochemical impedance spectroscopy. *Bioelectrochemistry*, 2016, 106, 64–72, doi: 10.1016/j.bioelechem.2015.04.002
- [3] ter Heijne A, Liu D, Sulonen M, Sleutels T, Fabregat-Santiago F. Quantification of bio-anode capacitance in bioelectrochemical systems using Electrochemical Impedance Spectroscopy. *Journal of Power Sources*, 2018, 400, 533–538, doi: 10.1016/j.jpowsour.2018.08.003
- [4] Kretzschmar J, Harnisch F. Electrochemical Impedance Spectroscopy on biofilm electrodes – conclusive or euphonious? *Current Opinion in Electrochemistry*, 2021, 8 (17), doi: 10.1016/j.coelec.2021.100757

Electrochemical characterization of the anodic biofilm activity in a methane-producing microbial electrolysis cell

Marco Zeppilli¹, Lorenzo Cristiani¹, Giuliano Fazi¹, Sergio Brutti¹, Mauro Majone¹, Marianna Villano^{1,*}

¹ Department of Chemistry, Sapienza University of Rome, P.le Aldo Moro 5, 00185 Rome (Italy)

*Email: marianna.villano@uniroma1.it

The electro-activity of the biofilm established at the anode of a fully biological methane-producing microbial electrolysis cell (MEC) is crucial to the overall process performance [1]. Indeed, the energy required to sustain the bioelectromethanogenesis reaction at the MEC cathode is partially provided by the anodic oxidation of (waste) organic substrates [2]. Also, the understanding of the biofilm response to operational fluctuations (such as the lack of substrate availability) is of fundamental importance for the industrial deployment of this technology.

This study analysed, primarily by means of cyclic voltammetry, the time-dependent evolution of the electrogenic activity of a biofilm enriched (from an activated sludge) at the anode of a lab scale two chamber MEC (ca. 1.7 L total volume), with the cathode finalized to methane generation. Notably, after a long period of starvation (about two months), the anodic biofilm fully recovered its electrogenic activity in less than one week after the feeding solution (consisting of a synthetic mixture of glucose, peptone, and acetate) was replenished. Clearly, methane production at the cathode was strongly dependent on the electrogenic activity of the anodic biofilm. Finally, the effect of the cathode temperature on the kinetics of electrotrophic methane production is currently being assessed.

Keywords: electrogenic activity, starvation, cyclic voltammetry, bioelectromethanogenesis

Funding: This research was supported by European Union—FESR “PON Ricerca e Innovazione 2014–2020. Progetto: Energie per l’Ambiente TARANTO—Cod. ARS01_00637”

References

- [1] Chiranjeevi P, et Patil SA. Strategies for improving the electroactivity and specific metabolic functionality of microorganisms for various microbial electrochemical technologies. *Biotechnology Advances*, 2020, 39: 107468.
- [2] Zeppilli M, et al. Bioelectromethanogenesis reaction in a tubular microbial electrolysis cell (MEC) for biogas upgrading. *Renewable Energy*, 2020, 158: 23.

The effect of the cathode current collector on the performance of a yeast-based air cathode microbial fuel cell

Joana Vilas Boas¹, Vânia Oliveira¹, Manuel Simões²,
Alexandra Rodrigues Pinto^{1,*}

¹ CEFT, Departamento de Eng. Química, Universidade do Porto, Faculdade de Engenharia, Rua Dr. Roberto Frias, 4200-465 Porto, Portugal

² LEPABE, Departamento de Eng. Química, Universidade do Porto, Faculdade de Engenharia, Rua Dr. Roberto Frias, 4200-465 Porto, Portugal

*Email: apinto@fe.up.pt

The successful deployment of microbial fuel cells depends on the development of cost-effective designs. The air cathode design is attractive since the air provides oxygen to the cathodic reaction by natural transfer mechanisms. However, the reaction kinetics is slower, limiting the cell performance [1]. The number of studies on how different current collector materials/structure can affect the oxygen transfer and the electrical conductivity is reduced [2]. Yet, current collectors are important components to fuel cells, providing electrical conductivity from the anode to the cathode, oxygen supply to the cathodic reaction and structural support to water pressure from the anode. The higher electrical conductivity of metals such as stainless steel (1.33×10^7 S/m) and titanium (1.79×10^7 S/m) should be considered over carbon [3]. Besides, metals present better mechanical strength which is an advantage in large-scale designs.

This work investigated the influence of the cathode current collector area/material on an air cathode microbial fuel cell performance inoculated with *Zygosaccharomyces bailii* and fed with a synthetic winery wastewater. Two pore sizes (3 and 6 mm) of titanium and stainless steel were tested. The best performance was achieved using a stainless steel plate with a pore size of 6 mm (41% of open ratio).

Keywords: air cathode microbial fuel cell, current collector, *Zygosaccharomyces bailii*, winery wastewater, power output.

Funding: The authors acknowledge the PhD scholarship (PD/BD/114314/2016) supported by “Fundação para a Ciência e a Tecnologia” (FCT), by “Fundos Nacionais do Ministério da Ciência, Tecnologia e Ensino Superior” (MCTES), inserted in the program “Programa Operacional Capital Humano” (POCH), cofinanced by Portugal 2020 and European Social Fund (ESF). The authors also acknowledge the national funding of FCT/MCTES (PIDDAC). POCI (FEDER) also supported this work via CEFT and LEPABE.

References

- [1] Zhang F, et al. Mesh optimization for microbial fuel cell cathodes constructed around stainless steel mesh current collectors. *Journal of Power Sources*, 2011; 196: 1097–1102.
- [2] Jung S, et al. Effects of wire-type and mesh-type anode current collectors on performance and electrochemistry of microbial fuel cells. *Chemosphere*, 2018; 209: 542-550.
- [3] Braz BA, et al. Optimization of a passive direct methanol fuel cell with different current collector materials. *Energy*, 2020; 208: 118394.

Scaling Up of Electro-Stimulated Anaerobic Reactor (ELSAR™) in the industrial wastewater treatment sector

Antonio Giménez Lorang¹, Naiara Hernández Ibáñez¹, Ángel Encinas Bogeat¹, Xavier Tomás Ortiz¹, Frank Rogalla¹, Victor M. Monsalvo García¹

¹ FCC Aqualia, Innovation & Technology Department, c/Balmes, 36, 08007 - Barcelona (Spain).

*Email: antonio.gimenez@fcc.es

On behalf of the EU project ULTIMATE (<https://ultimatewater.eu/>), Aqualia is developing the upscaling of the ELSAR™ (*Electro-Stimulated Anaerobic Reactor*) to be operated at Mahou San Miguel brewery in Lleida (Spain). The reactor designed will be able to treat up to 20 m³/h or 2000 kg COD/d (Figure 1).

The main milestones along the ideation and development of this technology are:

The original concept of the ELSAR™ system was co-developed and patented (“Method for treating wastewater in a fluidized bed bioreactor” (Ref. EP 2927196 A1)) by Aqualia and the University of Alcalá (UAH).

Performance lab and bench tests on behalf of the LIFE Answer project (<http://life-answer.eu/>) showed that ELSAR™ outperforms anaerobic fluidized bed reactor (AFBR) either under standard operational conditions or under stress operational tests (COD overload, biocide dosing, long starvation periods and operation at low temperatures) [1]. Long-term operation test was carried out with a 0.5 m³ prototype operated in real conditions.

A demo-scale 1m³ ELSAR™ is in operation since more than a year to validate the technology in a relevant environment treating municipal wastewater in Guijuelo (Spain, Figure 1).



Fig. 1. Demo-scale plant in Guijuelo (left) and 3D model of the demonstration WWTP based on ELSAR™ (right).

Keywords: anaerobic digestion, bioelectrochemistry, hydrogen, wastewater treatment, microbial electrochemical technologies

Funding: The project leading to this application has received funding from the European Union's Horizon 2020 research and innovation programme under Grant Agreement No 869318.

References

Asensio Y. *et al.* Upgrading fluidized bed bioelectrochemical reactors for treating brewery wastewater by using a fluid-like electrode. *Chemical Engineering Journal*, Volume 406, 2021, <https://doi.org/10.1016/j.cej.2020.127103>

Competitive advantages of a circular bioeconomy based on microbial electrosynthesis and CO₂

Jamin C. Wood,^{1*} Johannes Grové,² Esteban Marcellin,^{3,4} James K. Heffernan,³ Shihu Hu,¹ Zhiguo Yuan,¹ and Bernardino Viridis¹

¹ Advanced Water Management Centre, The University of Queensland, Brisbane, QLD 4072, Australia.

² Energy & Poverty Group, School of Chemical Engineering, The University of Queensland, Brisbane, QLD 4072, Australia.

³ Australian Institute for Bioengineering and Nanotechnology, The University of Queensland, Brisbane, QLD 4072, Australia.

⁴ Queensland Node of Metabolomics Australia, The University of Queensland, Brisbane, QLD 4072, Australia.

*Email: jamin.wood@uq.edu.au

Since the 18th century industrial revolution, fossil fuels have been the cornerstone of society. We have however reached a critical decade where deep cuts in greenhouse gas emissions will necessitate a fundamental shift in material foundation of our society. Inspired by the natural world, a circular carbon bioeconomy holds promise for recycling carbon dioxide into chemical, agricultural and fuel products (**Figure 1**). We developed a simplified technoeconomic framework based on levelised costs of chemicals (LCCs) to critically review two approaches in this space: microbial electrosynthesis and gas fermentation (**Figure 2**) [1]. Due to fundamental limits on acetogen electron uptake rate [2], we show the only viable pathway for scale-up of microbial electrosynthesis is through decoupling surfacedependent abiotic process for electron/hydrogen delivery from volume-dependent biotic carbon fixation, which effectively is an *electrolyser-assisted gas fermentation system*. Even then, high-value, but critically also high-volume, products are needed for economic viability such as butanol and single cell proteins (SCP) for human food consumption (as opposed, for example, to low-volume caproate). In keeping with the circular carbon bioeconomy ethos, we also suggest linking waste resource recovery with gas fermentation, though new technology such as reforming of biogas, as another potentially viable scale-up strategy.

Competitive advantages of a circular bioeconomy based on microbial electrosynthesis and CO₂

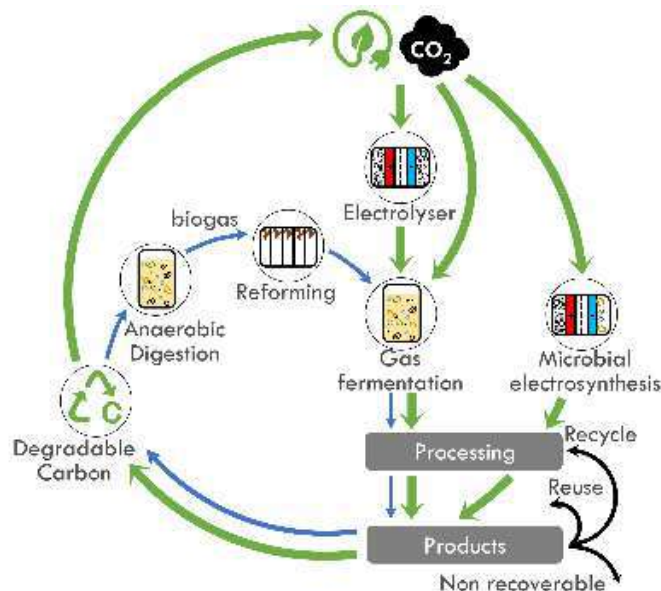

Synthesis Technology		1	2	3
Product	Market (US\$/kg)	LCC		
Acetate	0.65			
Ethanol	0.48			
Caproate	3.70			
Butanol	0.92			
SCP	15.00			

Figure 1. Circular carbon bioeconomy (green, blue), showing a closed carbon loop. There is minimal loss from the system, unlike the traditional economy.

Figure 2. LCC for select chemicals, colour coded according to how close the calculated value is to the market value. Production routes: **1** = microbial electrosynthesis, **2** = electrolyser-assisted gas fermentation, and **3** = biogas reforming-assisted gas fermentation. Data from [1].

Keywords: techno-economic analysis, circular economy, biogas, electron transfer

Funding: BV and ZY acknowledge the support of the Australian Research Council (ARC) for grants FL170100086 and DP160102308. EM acknowledges the support of ARC CoE in Synthetic Biology.

References

[1] Wood JC, et al. (*In press*). Strategies to improve viability of a circular carbon bioeconomy – A techno-economic review of microbial electrosynthesis and gas fermentation. *Water Res.*, WR_117306.
 [2] Claassens NJ, et al. 2019. Making quantitative sense of electromicrobial production. *Nat. Catal.*, 2019, 2, 437–447.

Wastewater treatment with a 1000 L microbial fuel cell: a 16-month experience

Maxime Blatter¹, Louis Delabays², Clément Furrer¹, Gérald Huguenin²,
Christian Pierre Cachelin⁴, Fabian Fischer^{1,3*}

¹ Institute of Life Technologies, HES-SO Valais-Wallis, Route du Rawyl 64, CH-1950 Sion

² Embedded-Computing Systems, Haute-Ecole Arc, Rue de la Serre 7, CH-2610 St-Imier

³ Institute of Sustainable Energy, HES-SO Valais-Wallis, Route du Rawyl 47, CH-1950 Sion

⁴ Institute of Systems Engineering, HES-SO Valais-Wallis, Route du Rawyl 47, CH-1950 Sion

*Email: fabian.fischer@hevs.ch

The construction of large microbial fuel cells (MFCs) and their long-term reliability are current challenges. MFCs generate power while purifying wastewater, save electricity, avoid pollutant stripping into the air and are a source of CO₂. To understand larger MFCs, a 1000-L MFC was designed. It was built from transparent polyester and electrodes were from reticulated vitreous carbon. Four power management devices were connected to an ensemble of 64 MFC units and assembled as a 12 m long MFC. Two Raspberry and a personal computer with Python programmed software automatized power management. The MFC was run for one year under maximum power point tracking (MPPT) [1]. Temperatures between 11.5 °C and 21 °C corresponded to WWTP conditions. The reactor shared electrolytes within 12 m long half-cells and 80 - 95% COD was removed generating 0.015 to 0.060 kWh/m³ with an energy efficiency of 5.8 - 12.1%. Voltage reversal were seen as potential imbalances among MFC units and all self-healing. Ammonium removal reached 48%, phosphorous was reduced to 0.59 mg/L, and micropollutants degraded by 67%. Biofilm mapping by 16S rRNA microbial community analysis indicated bi-sectorial metabolic properties. 10 Major genera were essential in the elongated scale up MFC generating electricity, reduced energy needed, and purified wastewater.



Fig. 1: 1000-L Microbial fuel cell in Wastewater Treatment Plant

Keywords: bioelectricity, scale-up, metabolism, wastewater, tracking, metagenomics

Funding: Swiss Federal Office of Energy (SI/501573-01) and "The Ark" foundation.

References

- [1] Blatter, M., Delabays, L., Furrer, C., Huguenin, G., Cachelin, C. P., & Fischer, F. (2021). Stretched 1000-L microbial fuel cell. *Journal of Power Sources*, 483, 229130.

Role of the C/N ratio in the feeding solution of a micro pilot microbial electrolysis cell aimed at biogas upgrading

Lorenzo Cristiani^{1*}, Marco Zeppilli¹, Jacopo Ferretti¹, Marianna Villano¹, Mauro Majone¹

¹ Department of chemistry, Sapienza university, Piazzale Aldo Moro 5, 00185 Rome

*Email: lorenzo.cristiani@uniroma1.it

Microbial electrolysis cells (MECs) permit to couple the oxidation of waste organic streams (e.g., wastewater or digestate) with the reduction of carbon dioxide into products with a high market value (e.g., methane or acetic acid). MECs exploit the ability of electroactive microorganisms to use a solid electrode as final electron acceptor or donor. Here, a micro pilot tubular MEC has been set up combining the anodic oxidation of the organic matter with the bioelectromethanogenesis reaction in the cathodic chamber. Seven different synthetic feeding solutions, simulating a domestic wastewater or an acidogenic fermentate, have been used to test different C/N ratio on the performance of the MEC bioanode in the range between 25 and 0.4 (molC/molN). As a main result it was found that, under the same operating conditions (i.e. anode potential controlled at +0.2 V vs SHE and HRT of 0.5 d), a high C/N ratio (e.g., 19 mol/mol) corresponded to an average current production of 288 ± 32 mA, that decreased to 161 ± 10 mA by applying a C/N ratio as low as 0.4 mol/mol. These findings are relevant for a practical application of the technology considering the variable content of carbon and nitrogen in real feedstocks.

Keywords: Biogas, upgrading, C/N ratio, Anodic biofilm, Pilot scale

Funding: This work has been carried out with the financial support of the NoAw project. "This project has received funding from the European Union's Horizon 2020 research and innovation programme under grant agreement No 688338".

IoT biosensing: a microbial electrochemical sensor for monitoring water quality

Antonio Berná^{1*}, Andrés de Deus^{2,3}, Daniela Torruella³, Carlos Manchón^{2,3}, Jesús Vázquez², Abraham Esteve-Núñez³

¹ IMDEA Water Institute, Av. Punto COM 2, 28805

² Nanoelectra S.L. - Av. Punto COM 2, 28805

³ University of Alcala - Department of Chemical Engineering, Pza. San Diego S/N - 28801

*Email: antonio.berna@imdea.org

Microbial Electrochemical Technologies boosted the potential applications of biotechnology based on electroactive microorganisms. Regarding the field of microbial sensing, the use of electroactive biofilms gathers the benefits of working with whole cells (low cost) and no need of using transducer elements of the metabolic activity [1,2].

Microbial electrochemical sensors are potentially good candidates for water quality monitoring. However, there are still some challenges to face that hinder the final step into the commercialization of these devices.

Main issues are related to power consumption and the limited number of sensing analytes. Despite the possibility to be self-powered (MFC), the performance as biosensor is poorer when this configuration is chosen [3]. The reason remains in the lack of potential control.

Authors have addressed these issues designing and constructing an electrochemical biosensor so-called IoT biosensing ready for market uptake. This sensor consists of a low power potentiostat, an online data acquisition and 4G transmission module, and a three electrode bioelectrochemical system, all powered by a photovoltaic solar panel and a battery. Progress achieved during monitorization of water quality in relevant environments like real wastewater treatment plants and groundwater are shown.



Fig. 1 A) IoT microbial electrochemical biosensor for in situ and online monitoring of water quality.

Keywords: microbial electrochemical sensor, water quality, 3D bioprinting, IoT, online monitoring

Funding: 4KET4Reuse project, Interreg Sudoe program (SOE1/P1/E0253), PRINTBIO project, H2020 ATTRACT program (N° 777222).

References

- [1] PrévotEAU, A and Rabaey, K. Electroactive biofilms for sensing: Reflections and perspectives. *ACS Sensors*, 2017, 2 (8): 1072.
- [2] Estevez-Canales, M, Berná, A, Borjas, Z y Esteve-Núñez, A. Screen-Printed electrodes: New tools for developing microbial electrochemistry at microscale level. *Energies*. 2015, 8: 13211.

- [3] Kretschmar, J, Koch, C, Liebetrau, J, Mertig, M y Harnisch, F. Electroactive biofilms as sensor for volatile fatty acids: Cross sensitivity, response dynamics, latency and stability. *Sensors and Actuators B: Chemical*, 2017, 241: 466.

Crossing the wall: extracellular electron transfer in Gram-positive bacteria

Paquete, C.M.^{1,*}, Faustino, M.¹, Costa, N.L.¹, Fonseca, B.M.¹, Lousa, D.¹, Louro, R.O.¹

¹ Instituto de Tecnologia Química e Biológica António Xavier, Universidade Nova de Lisboa, Av. da República, 2780-157 Oeiras, Portugal

*Email: cpaquete@itqb.unl.pt

Extracellular electron transfer (EET) is a metabolic process that enables electroactive bacteria to exchange electrons with electrodes in bioelectrochemical systems (BES). The understanding of the EET processes performed by these organisms is crucial to advance the implementation of BES, as well as advance their biotechnological application [1,2]. Gram-positive bacteria have attracted the scientific interest, given their ability to produce high levels of current in MFC, in particular at high temperatures [3,4]. *Thermincola ferriacetica* Z-0001, was assembled at ~100× coverage from 100-bp paired-end Illumina reads. The draft genome contains 3,274 predicted genes (3,187 protein coding genes). The EET pathway of Gram-positive bacteria belonging to *Thermincola* sp. is composed by four multiheme c-type cytochromes: the inner-membrane decaheme cytochrome A (ImdcA); the periplasmic decaheme cytochrome A (PdcA); the cell-wall cytochrome A (CwcA) and the outer cell-wall cytochrome A (OcwA) [5,6]. The range of redox potentials in which ImdcA, PdcA and OcwA from *T. ferriacetica* are electrochemically active are adequate to extract electrons from low-potential quinone pools in the membrane and transfer them to insoluble electron acceptors, outside of the cell (Figure 1) [6,7].

Using sequence homology modelling the 3D-architecture of CwcA is proposed, showing a novel potential pathway for electrons to be transferred across the thick peptidoglycan cell-wall. The results presented here demonstrate for the first time the EET pathway by which bacteria belonging to *Thermincola* sp. transfer electrons to extracellular electron acceptors, including electrodes in BES.

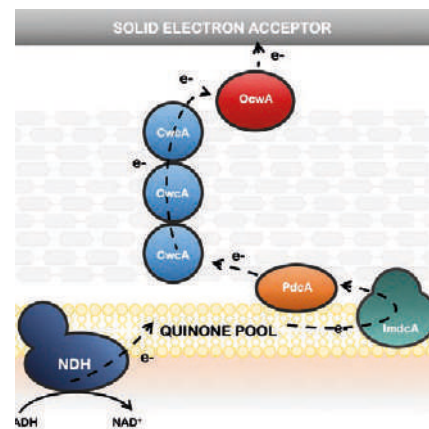

Fig. 1 Representative scheme of the EET pathway of *T. ferriacetica*

Keywords: *Thermincola*, multiheme c-type cytochromes, bioelectrochemical systems, electrochemical activity

References

- [1] Zhao J et al. Microbial extracellular electron transfer and strategies for engineering electroactive microorganisms. *Biotechnol Adv* 2020. (in press).
- [2] Ikeda S et al. *Shewanella oneidensis* MR-1 as a bacterial platform for electro-biotechnology .

Essays Biochem 2021;0:1–10

- [3] Lusk BG et al. Draft Genome Sequence of the Gram-Positive Thermophilic Iron Reducer *Thermincola ferriacetica* Strain Z-0001T. *Genome Announc* 2015;3.

- [4] Wrighton KC et al. A novel ecological role of the Firmicutes identified in thermophilic microbial fuel cells. *ISME J* 2008;2:1146.

- [5] Paquete CM. Electroactivity across the cell wall of Gram-positive bacteria. *Comput Struct Biotechnol J* 2020;18:3796

- [6] Faustino MM et al. Crossing the wall: Characterization of the multiheme cytochromes involved in the extracellular electron transfer pathway of *Thermincola ferriacetica*. *Microorganisms* 2021;9

- [7] Costa NL et al. How Thermophilic Gram-Positive Organisms Perform Extracellular Electron Transfer: Characterization of the Cell Surface Terminal Reductase OcwA. *mBio* 2019;10:e01210.

Bioelectrochemical characterization of a cytochrome belonging to the NapC/NirT family from *Sideroxydans lithotrophicus* ES-1

Anaísa Coelho^{1*}, Abhiney Jain², Joana Madjarov¹, Ricardo O. Louro¹, Jeffrey A. Gralnick², Catarina M. Paquete¹

¹ Instituto de de Tecnologia Química e Biológica António Xavier, Universidade Nova de Lisboa, Av. da República, 2780-157 Oeiras, Portugal

² BioTechnology Institute and Department of Plant and Microbial Biology, University of Minnesota — Twin Cities, St. Paul, MN 55108

*Email: anaisancoelho@itqb.unl.pt

Electroactive microorganisms have attracted significant interest for the development of bioelectrochemical systems (BES) for the sustainable production of energy and added-value products [1]. These organisms perform extracellular electron transfer which has been demonstrated to be carried out by numerous multiheme c-type cytochromes. One of these proteins is the membrane-bound tetraheme cytochrome c, CymA, a member of the NapC/NirT family of quinol dehydrogenases [2]. It has been proposed that in *Shewanella oneidensis* MR-1 CymA acts as a hub for electron transfer to multiple periplasmic partners, functioning as a quinol oxidase during Fe(III) reduction [3, 4]. Interestingly, the freshwater chemolithoautotroph *Sideroxydans lithotrophicus* ES-1 also contains a NapC/NirT family tetraheme cytochrome containing a protein encoded by *Slit_2495* that has been proposed to function as the quinone reductase during Fe(II) oxidation based on its sequence similarity with CymA [5]. To understand the difference between these two proteins belonging to the NapC/NirT family, we heterologously expressed *Slit_2495* and characterized the protein regarding its biochemical and electrochemical properties. This information is the first step in the complete elucidation of its mode of action, a knowledge that is still lacking and is crucial to use and improve this organism towards practical biotechnological applications.

Keywords: *Sideroxydans lithotrophicus* ES-1, NapC/NirT protein, CymA, *Slit_2495*, bioelectrochemical characterization

Funding: Doctoral fellowship PD/BD/135153/2017 integrated in the PhD Programme in NMR applied to chemistry, materials and biosciences (PD/00065/2013).

References

[1] S. Bajracharya, et al. An overview on emerging bioelectrochemical systems (BESs): Technology for sus-

tainable electricity, waste remediation, resource recovery, chemical production and beyond. *Renewable Energy*, 2016, 98:153.

[2] C. R. Myers and J. M. Myers. Cloning and sequence of *cymA*, a gene encoding a tetraheme cytochrome c required for reduction of iron(III), fumarate, and nitrate by *Shewanella putrefaciens* MR-1. *J. Bacteriol.*, 1997, 179(4):1143.

[3] D. G. G. McMillan, et al. Menaquinone-7 is specific cofactor in tetraheme quinol dehydrogenase CymA. *J. Biol. Chem.*, 2012, 287(17):14215.

[4] C. Schwalb, et al. The tetraheme

cytochrome CymA is required for anaerobic respiration with dimethyl sulfoxide and nitrite in *Shewanella oneidensis*. *Biochemistry*, 2003, 42(31):9491.

[5] C. R. Beckwith, et al. Characterization of MtoD from *Sideroxydans lithotrophicus*: A cytochrome c electron shuttle used in lithoautotrophic growth. *Front. Microbiol.*, 2015, 6.

[6] D. Emerson, et al. Comparative genomics of freshwater Fe-oxidizing bacteria: Implications for physiology, ecology, and systematics. *Front. Microbiol.*, 2013, 4:1.

Extracellular electron transfer in a *C. ljungdahlii*-based platform for microbial electrosynthesis

Santiago T. Boto^{1,2}, Miriam A. Rosenbaum^{1,2*}

¹ Leibniz Institute for Natural Product Research and Infection Biology

Hans Knöll Institute (HKI), Beutenbergstraße 11a, 07745, Jena (Germany)

² Faculty of Biological Sciences, Friedrich Schiller University, 07743, Jena (Germany)

*Email: miriam.rosenbaum@leibniz-hki.de

Microbial electrosynthesis has recently emerged as an alternative way of biologically producing organic chemicals from carbon dioxide using electricity. These processes could play a very important role in the ecological transition substituting chemical production from fossil fuels. Nevertheless, microbial electrosynthesis is currently limited by the poor control and understanding over the biological aspects of the process. In order to increase the viability and applicability of microbial electrosynthesis, a deeper knowledge about the mechanisms of electron transfer is required. In acetogens, and more specifically in *Clostridium ljungdahlii*, biofilm-dependent direct electron transfer was initially proposed¹ while the most recent studies tend to assume hydrogen-mediated electron transfer as the main electron transfer mechanism involved². In our study, we aim at the clarification of the electro-physiology of *C. ljungdahlii* and its role in hydrogen evolution, using online *in situ* data collection and altering biotic factors. With a deeper understanding of biological parameters, we seek to achieve higher planktonic densities and more robust systems that decouple growth from biofilm formation. Hence, the improvement of *C. ljungdahlii* performance in microbial electrosynthesis leads to scalable and feasible electro-fermentations.

Keywords: Microbial electrosynthesis, Hydrogen evolution, *Clostridium ljungdahlii*

Funding: Deutsche Forschungsgemeinschaft

References

- [1] Nevin K P, et al. Electrosynthesis of organic compounds from carbon dioxide is catalyzed by a diversity of acetogenic microorganisms. *Applied and Environmental Microbiology*, 2011, 77 (9) 2882-2886.
- [2] PrévotEAU A, et al. Microbial electrosynthesis from CO₂: forever a promise? *Current Opinion in Biotechnology*, 2020, 62:48-57.

Charge transfer parameters through biofilms of an enhanced current-producing *Geobacter sulfurreducens* strain reveal increased electron transfer diffusion rate

Fernanda Jiménez Otero^{1*}, Grayson Chadwick², Matthew Yates³, Rebecca Mickol⁴, Scott Saunders², Sarah Glaven³, Jeffrey Gralnick⁵, Dianne Newman², Leonard Tender³, Victoria Orphan², and Daniel Bond⁵

¹ George Mason University, Fairfax, VA, 22030

² California Institute of Technology, Pasadena, CA, 91125

³ US Naval Research Laboratory, Washington, DC, 20375

⁴ American Society for Engineering Education, Washington, DC, 20036

⁵ University of Minnesota, Saint Paul, MN, 55108

*Email: fjimenez@gmu.edu

A strain of *Geobacter sulfurreducens* lacking four out of five outer membrane cytochrome complexes (strain *extABCD*⁺) grows with a faster doubling time and produces 37% greater current density compared to wild type grown under identical conditions. Increased rates of ¹⁵N incorporation and closer cell packing within the first 5 μm from the electrode in *extABCD*⁺ biofilms compared to wild type revealed higher metabolic activity. To understand how this phenotype is sustained during extracellular electron transfer, long-distance electron transfer parameters (C_T = charge carrier concentration and D_{app} = electron diffusion rate) were measured for wild-type and *extABCD*⁺ biofilms grown on interdigitated gold electrodes spanning 5 μm gaps. Our results reveal that *extABCD*⁺ biofilms achieved higher current densities through an increased rate of electron transfer through *extABCD*⁺ vs. wild-type biofilms, suggesting that denser biofilms resulting from the deletion of unnecessary multi-heme cytochromes streamlines electron transfer to electrodes. This work confirms that reducing the extracellular electron transfer pathway down to the components necessary during electron reduction is an effective strategy to construct strains producing more current per cell and, in combination with higher biofilm density and electron diffusion rates, reaching a higher final current density than wild type.

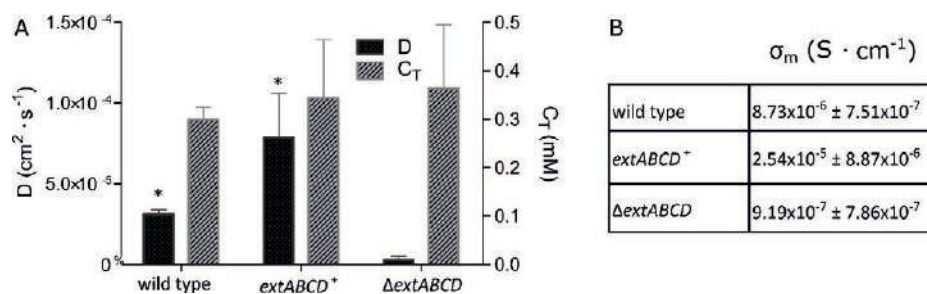

Fig. 1 Charge transfer parameters of wild-type, *extABCD*⁺, and Δ*extABCD* biofilms. A) Charge carrier concentration (C_T), diffusion coefficient (D), $n = 3$, $*p = 0.0379$. B) Conductivity (σ_m) of electron transport through biofilm matrix values calculated from generator-collector and square wave voltammetry measurements.

Keywords: *Geobacter sulfurreducens*, c-type cytochrome electron conduit

References

[1] Jimenez Otero, *et al.* Evidence of streamlined extracellular electron transfer pathway from biofilm structure, metabolic stratification, and long-range electron transfer parameters. *App. Environ. Microbio.*, 2021, *In press*

Electron uptake in MES: How does *Sporomusa ovata* accept electrons at the cathode?

Joana Madjarov*, Catarina M. Paquete, Ricardo O. Louro

ITQB NOVA, Av. da República, 2780-157 Oeiras

*E-mail: : joana.madjarov@itqb.unl.pt

Sporomusa ovata is by far the most successful microorganism in pure culture to produce acetate from carbon dioxide and current [1]. And the literature shows that improving the performance by means of choosing or manufacturing new electrode materials [2]–[4], adjusting trace elements [5], adapting the bacteria [6], [7], or varying temperature [8] is possible. But there is still the unanswered crucial question of the electron uptake mechanism: is direct electron uptake possible, or does *S. ovata* rely on intermediate hydrogen production on the electrode?

Analysis of the proteome (Uniprot and NCBI) of *S. ovata* reveals genes coding for 8 different multiheme c-type cytochromes which could contribute to a direct electron uptake pathway. But genes coding for hydrogenases and nitrogenases are also present. Therefore, an indirect pathway through the intermediate hydrogen production is also possible. Which of both pathways is used or predominant is not yet investigated.

To contribute to reveal the fundamentals of electron uptake of *S. ovata*, this work has thoroughly reviewed achievements of this bacterium in MES and analysed its genome. Experimental work characterizing involved protein families under different operation parameters (cathode potential and gas supply) is underway.

Keywords: Microbial electrosynthesis, *Sporomusa ovata*, Electron uptake mechanisms, Protein analysis

Funding: MSCA Individual Widening Fellowship (BIOCAT, Project number: 408509).

References

- [1] S. Das, L. Diels, D. Pant, S. A. Patil, and M. M. Ghangrekar, "Review—Microbial Electrosynthesis: A Way Towards The Production of Electro-Commodities Through Carbon Sequestration with Microbes as Biocatalysts," *J. Electrochem. Soc.*, vol. 167, no. 15, p. 155510, 2020, doi: 10.1149/1945-7111/abb836.
- [2] N. Aryal, A. Halder, P. L. Tremblay, Q. Chi, and T. Zhang, "Enhanced microbial electrosynthesis with three-dimensional graphene functionalized cathodes fabricated via solvothermal synthesis," *Electrochim. Acta*, vol. 217, pp. 117–122, 2016, doi: 10.1016/j.electacta.2016.09.063.
- [3] N. Aryal, P.-L. Tremblay, M. Xu, A. E. Daugaard, and T. Zhang, "Highly Conductive Poly(3,4-ethylenedioxythiophene) Polystyrene Sulfonate Polymer Coated Cathode for the Microbial Electrosynthesis of Acetate From Carbon Dioxide," *Front. Energy Res.*, vol. 6, no. July, pp. 1–7, 2018, doi: 10.3389/fenrg.2018.00072.
- [4] N. Aryal et al., "Freestanding and flexible graphene papers as bioelectrochemical cathode for selective and efficient CO₂ conversion," *Sci. Rep.*, vol. 7, no. 1, pp. 1–8, 2017, doi: 10.1038/s41598-017-09841-7.
- [5] F. Ammam, P.-L. Tremblay, D. M. Lizak, and T. Zhang, "Effect of tungstate on acetate and ethanol production by the electrosynthetic bacterium *Sporomusa ovata*," *Biotechnol. Biofuels*, vol. 9, no. 1, p. 163, 2016, doi: 10.1186/s13068-016-0576-0.
- [6] P. L. Tremblay, D. Höglund, A. Koza, I. Bonde, and T. Zhang, "Adaptation of the autotrophic acetogen *Sporomusa ovata* to methanol accelerates the conversion of CO₂ to organic products," *Sci. Rep.*, vol. 5, no. October, pp. 1–9, 2015, doi: 10.1038/srep16168.
- [7] X. C. Shi, P. L. Tremblay, L. Wan, and T. Zhang, "Improved robustness of microbial electrosynthesis by adaptation of a strict anaerobic microbial catalyst to molecular oxygen," *Sci. Total Environ.*, vol. 754, p. 142440, Feb. 2021, doi: 10.1016/j.scitotenv.2020.142440.
- [8] N. Faraghiparapari and K. Zengler, "Production of organics from CO₂ by microbial electrosynthesis (MES) at high temperature," *J. Chem. Technol. Biotechnol.*, vol. 92, no. 2, pp. 375–381, 2017, doi: 10.1002/jctb.5015.

Life cycle assessment of Microbial Electrosynthesis

Siddharth Gadkari^{1,2,*}, Jhuma Sadhukhan^{1,2}

¹ Department of Chemical and Process Engineering,
University of Surrey, Guildford GU2 7XH, UK

² Centre for Environment and Sustainability, University of
Surrey, Guildford, GU2 7XH, UK

*Email: s.gadkari@surrey.ac.uk

Microbial electrosynthesis (MES) offers a potentially sustainable route of producing useful platform and commodity chemicals. Here we present the environmental burdens associated with acetic acid (AA) production via MES. While downstream separation and purification remains the top environmental hotspot, membrane and reactor medium are the other significant contributors. A sensitivity analysis, assuming a more productive MES system with space time yield equal to that reported for acetogenic bacteria in a continuous gas fermenter ($148 \text{ gL}^{-1}\text{d}^{-1}$) is also presented. This analysis is based on four scenarios, which involve either fed-batch or continuous operation, with electricity source as either grid power or a photovoltaic facility. Impact assessment results show that for the assumed high productivity, the environmental impact of AA production using MES could become comparable to traditional fossil-based method, but only if the energy source is completely renewable, which is a significant challenge. Among the two modes of operation, fed-batch processing leads to higher environmental impact, however, the product accumulation helps in achieving the same performance at low production rate as compared to continuous mode. A threshold production rate for a fed-batch MES reactor that could possibly lead to sustainable AA production was found to be $4100 \text{ gm}^{-2}\text{d}^{-1}$.

Keywords: microbial electrosynthesis, LCA, acetic acid, sustainability

Increasing the voltage in series-stacked bioelectrochemical systems, a road towards technology up-scaling

Pau Bosch-Jimenez^{1*}, Daniele Molognoni¹, Jordi Suarez¹,
Monica Della Pirriera¹, Eduard Borràs¹

¹ LEITAT Technological Center, C/ de la Innovació 2, 08225 Terrassa, Spain

*Email: pbosch@leitat.org

Series-stacked bioelectrochemical systems (BES) are appealing in terms of energy conversion, operating at higher voltages and approaching industrial power application of BES. In case of energy-consuming BES connected in series, like microbial electrolysis cells (MEC), high-performing bioanodes can push less-performing ones in the stack outside their “working zone”, resulting in unbalanced voltage drops and damage of electroactive biofilm. In this study, a passive and low-cost cell balance system (CBS) was proposed, solving this key issue for BES up-scaling.

Three double-chamber MECs were adopted and connected in series. Diodes were placed in parallel to each cell, acting as passive “bypass line” and allowing the excess current to flow outside of the individual MEC when its voltage drop exceeded the disruptive voltage of the diode. Diodes were selected for their disruptive voltage to be slightly lower than maximum voltage tolerated by individual MECs ($\approx 1,5$ V). Several tests were performed operating the stack in chronoamperometric mode (Table 1). Then, CBS was installed, and tests repeated with protected stack (Table 2).

The unprotected stack failed at a stack voltage of 4,5 V. With the protected stack, the voltage remained balanced. Developed CBS can be applied to different BES technologies, facilitating their industrial uptake.

Stack voltage	Stack current	MEC 1			MEC 2			MEC 3		
		E_{an}	E_{cat}	ΔE	E_{an}	E_{cat}	ΔE	E_{an}	E_{cat}	ΔE
3,0	3,8	-0,30	-1,40	1,10	-0,45	-1,40	0,95	-0,40	-1,40	1,00
3,5	5,4	-0,31	-1,57	1,26	-0,43	-1,51	1,08	-0,37	-1,51	1,14
4,0	6,0	-0,26	-1,75	1,49	-0,40	-1,59	1,19	-0,30	-1,59	1,29
4,5	5,9	+0,26	-1,74	2,00	-0,40	-1,59	1,19	-0,31	-1,59	1,28
3,0	4,2	-0,41	-1,40	0,99	-0,46	-1,43	0,97	-0,44	-1,44	1,00
3,5	6,0	-0,43	-1,55	1,12	-0,45	-1,58	1,13	-0,43	-1,59	1,16
4,0	7,9	-0,41	-1,68	1,27	-0,42	-1,71	1,29	-0,41	-1,72	1,31
4,5	11,1	-0,39	-1,84	1,45	-0,40	-1,87	1,47	-0,38	-1,87	1,49

Table 1 – Electrodes potentials (E_{an} and E_{cat} , in V vs Ag/AgCl), cell voltage drops (ΔE , in V) and current (mA) measured with the series-connected stack of MECs, at different values of stack voltage.

Table 2 – Electrodes potentials (E_{an} and E_{cat} , in V vs Ag/AgCl), cell voltage drops (ΔE , in V) and current (mA) measured with the series-connected stack of MECs, at different values of stack voltage, when adopting the CBS.

Keywords: cell balance system, diode, microbial electrochemical technologies, stack.

Funding: This project has received funding from European Union’s Horizon 2020 research and innovation programme under Grant Agreement no. 826312 (GREENER).

Development of Innovative Soil Microbial Fuel Cells for Energy Harvesting

Jakub Dziegielowski¹, Mirella Di Lorenzo*

¹ Department of Chemical Engineering and Centre for Biosensors, Bioelectronics & Biodevices (C3Bio), University of Bath, Claverton Down, BA2 7AY, UK

Email: m.di.lorenzo@bath.ac.uk

Soil microbial fuel cells (SMFCs) have great potential as an energy harvesting technology. Amongst the different types of microbial fuel cells, SMFCs are arguably the most cost attractive, as they utilise soil as the supporting matrix, the source of microorganisms, and, in membrane-less configurations, also as the separator between the anode and the cathode. Consequently, the overall design of the fuel cell is simplified and so is its operation, since no fuel continuous pumping/ replacement is required.

Nonetheless, similarly to traditional (liquid) microbial fuel cells, practical applications of SMFCs are hindered by the difficulties with power scale-up and issues with long-term stability. Finding the most practical and energy efficient strategy to operate SMFCs is crucial for successfully transitioning this technology into the market.

We focus on the design and development of low-cost SMFCs, including an extremely simple flat-plate geometry, with the anode embedded into the soil and the cathode exposed to air, as well as more complex arrangements with vertical electrodes. We also work at the development of functional electrical arrangement of multiple SMFC units to boost the power output. In particular, a net power positive energy harvesting strategy is considered for the power management system, which is based on an equivalent electrical circuit model and continuous maximum power point tracking algorithm approach, with no need for energy consuming equipment. With this approach, we show the remote powering of electronic devices, including an electrochemical reactor for water purification.

Keywords: Soil microbial fuel cells, Bioenergy, equivalent electrical circuit, maximum power point tracking

Funding: This work is part of the project GREENER that has received funding from the European Union's Horizon 2020 research and innovation programme under the grant agreement No 826312.

MIDES H2020 Project: Microbial Desalination for Low Energy Drinking Water. From lab-scale concept to Pilot Plant validation.

Marina Ramírez-Moreno¹, Pau Rodenas¹, Martí Aliaguilla², Pau Bosch-Jimenez², Eduard Borràs-Camps², Patricia Zamora³, Víctor Monsalvo-García³, Frank Rogalla³, Juan M. Ortiz¹, Abraham Esteve-Núñez^{1,4}

¹IMDEA Water Institute, Avenida Punto Com, 2, Parque Científico Tecnológico de la Universidad de Alcalá, 28805, Alcalá de Henares, Madrid, Spain.

²LEITAT Technological Center, C/Pallars, 179-185, 08005 Barcelona, Spain.

³FCC Aqualia S.A., Avenida del Camino de Santiago, 40, Building 3, 4th floor, 28050, Madrid, Spain.

⁴Department of Analytical Chemistry, Physical Chemistry and Chemical Engineering Department, Universidad de Alcalá, Alcalá de Henares, Spain.

*Email: juanma.ortiz@imdea.org

The EU-H2020 MIDES project aimed to develop the World's largest demonstrator of an innovative and low-energy technology for drinking water production, using Microbial Desalination Cells (MDC) technology as pre-treatment step for RO. The project focused on overcoming the current limitations of MDC technology such as low desalination rate, high manufacturing cost, biofouling and scaling problems on membranes, optimization of the microbial-electrochemical process, integration with RO, ceramic nano-membranes as pre-treatment, system scale up and economic feasibility of the technology. The project run from 2016 to 2020, to develop the world's largest demonstrator of the innovative MDC technology. Demonstration sites were implemented in Spain in Denia (brackish water) and in Las Palmas (sea water). This communication presents the main outcomes of the project, the process to scale-up MDC technology from lab-scale concept, and the future outlook and prospective of MDC technology [1].

Fig. 1. Microbial desalination cells developed in the MIDES project, fabricated at the following scales: a) MDC laboratory area 100 cm²; b) pre-pilot MDC unit, area 600 cm²; c) pre-pilot MDC stack, area 600 cm² x 10; d) MDC pilot unit, area 4000 cm² and e) MDC pilot stack, area 4000 cm² x 15.

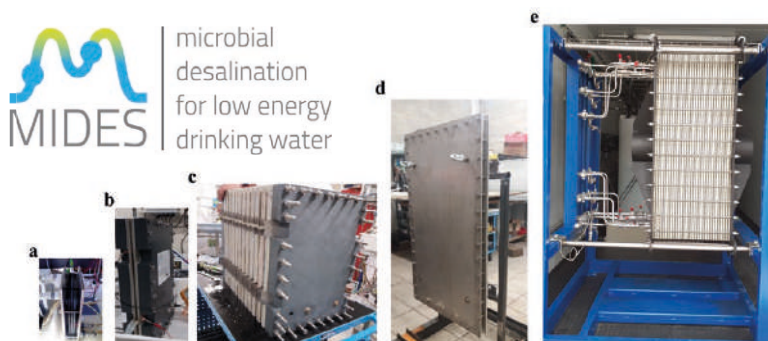

Keywords: microbial desalination cell, brackish water, electrochemistry, fresh water production.

Funding: Project "MIDES – H2020" has received funding from

the European Union's Horizon 2020 research and innovation programme (N° 685793).

References

[1] Salinas Rodríguez, S.G., Arévalo, J., Ortiz, J.M., Borràs-Camps, E.,

Monsalvo-García, V., Kennedy, M.D., Esteve-Núñez, A. (2021). Microbial Desalination Cells for Low Energy Drinking Water. London: IWA Publishing. ISBN13:9781789062113 (Paperback). ISBN:9781789062120 (eBook). Doi: 10.2166/9781789062120

Full scale operation of decentralized urban wastewater using METland® technology

Abraham Esteve-Núñez^{1,2,3*}, Ramón Esteve², Mario Gimenez², Lorena Peñacoba-Antona², Manuel López², Carlos Ramírez-Vargas⁴, Carlos Arias⁴, Juan José Salas²

¹ IMDEA Water Institute, Av. Punto Com, 2, Parque Científico Tecnológico, 28805 Alcalá de Henares, Madrid, Spain.

² Universidad de Alcalá, Departamento de Química Analítica, Química Física e Ingeniería Química, Ctra. Madrid-Barcelona Km. 33.600, 28871, Alcalá de Henares (Madrid), Spain.

³ METfilter S.L., Autovía A49 Sevilla-Huelva Km 28, 41820 Carrión de los Céspedes, Sevilla, Spain.

⁴ Department of Biology - Aquatic Biology, Aarhus University, Ole Worms Allé 1, 8000 Aarhus C, Denmark, abraham.esteve@uah.es

METland® represent a hybrid concept of nature-based solution by integrating MET-based concepts like CIET (conductive-mediated interspecies electron transfer) into a constructed wetland design for generating a new generation of electroconductive biofilters for treating wastewater. Different configurations and operation modes (Aguirre et al., 2020) have been tested in the last decade to eventually generate a sustainable strategy according to LCA analysis (Peñacoba et al., 2021) capable to maximize electrobioremediation rates. A number of full scale application are currently operating at different international locations. In this work we report three different successful cases regarding design, bioremediation performance, electrochemical performance and microbial community analysis: i) Modular METland® downflow configuration; 20-25m³/day of sulfate-rich urban waste water from Otos municipality (Spain) were treated in 16 m²; b) Multi stage constructed METland® downflow configuration, 100m³/day from a Camping site (Spain) were treated in 40 m²; iii) Constructed METland® for treating (20m³/day) from Orby municipality (Denmark) in 80 m². METland® exhibited generated effluents with COD values as low as 30ppm or below 1ppm in ammonium. Electrobioremediation was correlated with electron flow measured as electric potential profile (Prado et al., 2020). Interestingly, emergent contaminants like drugs and hormones were also efficiently removed under METland® conditions.



Fig. 1 Images of different full scale configurations for METland® technology in Spain and Denmark, and Electric Potential profile of electroconductive bed

Keywords: electrobioremediation, METland, CIET, water management, reclaimed water

Funding: This investigation was funded by European Union's Horizon 2020 research and innovation program under the grant agreement No. 642190 (www.imetland.eu) and No. 826244 (www.electra.site). Lorena Peñacoba-Antona and Mario Jimenez-Conde were funded by the industrial PhD fellowship program from the Regional Government of Madrid, Ref. IND2017/AMB-7648 and IND2018/AMB-9197.

References: Aguirre-Sierra, A. et al. A new concept in constructed wetlands: assessment of aerobic electroconductive biofilters. *Environmental Science: Water Research & Technology*, 2020, 6 (5), 1312-1323.
Peñacoba-Antona, L. et al. Assessing METland® design and performance through LCA: techno-environmental study with multifunctional unit perspective. *Frontiers in Microbiology*, 2021.
Prado, A., Ramírez-Vargas, C.A., Arias, C.A., Esteve-Núñez, A., 2020. Novel bioelectrochemical strategies for domesticating the electron flow in constructed wetlands. *Sci. Total Environ.* 735, 139522.

Enhancing butanol production by *Clostridium beijerinckii* through cathodic electro-fermentation approach

Daniele Molognoni^{*}, Alba Suarez Sousa¹, Annabel Serpico¹, Ana Lopez Contreras², Guiomar Sanchez¹, Pau Bosch-Jimenez¹, Eduard Borràs¹

¹ LEITAT Technological Center, C/ de la Innovació 2, 08225 Terrassa, Barcelona (Spain)

² Wageningen Food & Biobased Research - 6700 AA Wageningen (The Netherlands)

*Email: dmolognoni@leitat.org

Biobutanol, produced by solventogenic bacteria like *Clostridium beijerinckii* through ABE fermentation, is a promising green fuel. Electro-fermentation (EF) can modify the oxidation-reduction potential (ORP) of the fermentation broth, manipulating the ratio of oxidized nicotinamide adenine dinucleotide to reduced nicotinamide (NAD⁺/NADH), a critical intracellular factor for butanol synthesis. This study focuses on a glucose-based EF at laboratory-scale. Three replicate bioelectrochemical reactors were adopted. Chronoamperometry tests at constant cathode potential were run (E_{cat} ranging from -0.7 to -1.0 V vs Ag/AgCl). Poising E_{cat} at -0.8 V vs Ag/AgCl resulted in the optimal EF scenario, with microbial growth rate of 0.08 g/L/h (56% higher than benchmark fermentation), production of 0.13 g-butanol/L/h, yield of 0.19 g-butanol/g-glucose and selectivity of 87% (44%, 19% and 12% higher than benchmark, respectively). A titer of 5.8 g-butanol/L was reached after 46 h. At adopted E_{cat} , H₂ production was limited (HER onset at -0.7 V vs Ag/AgCl) and only 0,4% of produced solvents were attributable to electro-trophic *C. beijerinckii* metabolism. A major part of them were produced by spontaneous fermentation, with intracellular metabolism shifted towards butanol, thanks to EF approach.

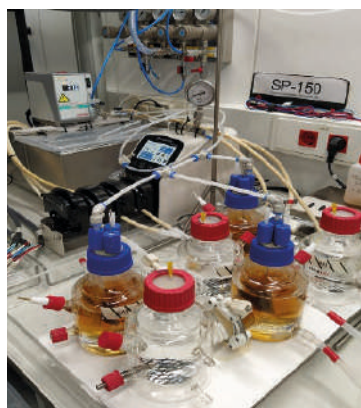

Parameter	Anode	Cathode
Chamber volume	300 mL	300 mL
Electrode surface	9 cm ²	5 cm ²
Electrode material	Ir-MMO coated Ti-mesh	MnO ₂ coated carbon cloth
Electrolyte	0,1 M PBS	60 g/L glucose, anaerobic cond.
Inoculum	abiotic	<i>C. beijerinckii</i>
Temperature	Room T (≈24 °C)	37 °C, constant
Separator	Cationic exchange membrane	

Keywords: bioelectrochemical systems, biofuels, butanol, cathode, fermentation

Funding: This project has received funding from the European Union's Horizon 2020 research and innovation programme under Grant Agreement no. 761042 (BIOCON-CO2).

Statistical analysis on factors affecting microbial electrosynthesis (MES)

Thulluru Lakshmi Pathi¹, Narnepati Krishna Chaitanya², Pritha Chatterjee^{1,2*}

¹ Department of Climate Change - Indian Institute of Technology - Hyderabad - India - 502285

² Department of Civil Engineering, Indian Institute of Technology, Hyderabad - India - 502285

*Email: pritha@ce.iith.ac.in

Carbon capture and utilization (CCU) techniques help in mitigating greenhouse gases (GHGs), mainly CO₂ and simultaneously produce multi-carbon compounds. Microbial electrosynthesis (MES) is one such technique. Advancements in MES studies can be understood by comparing their production rate. However, product titers reported in literature are not comparable directly, as they depend on many operational factors. In order to enable comparison between the different studies, a statistical analysis was performed by collecting data from studies that had results of at least two MES with only one factor varying. The MES performance (P), in terms of production rate were normalized to the maximum MES performance (P_{max}) obtained in the same study and impact of each factor was analysed individually. The analysis revealed that best performance was obtained for pure CO₂ as a carbon source as compared to bicarbonates or industrial off gas. Similarly, neutral to alkaline pH (7-10) both during inoculation and operation gave better performance. Operation of reactor in continuous mode as compared to batch mode resulted in reduced product inhibition, thereby giving a better titer. Similar statistical studies on more number of factors will help us understand MES performance better and eventually design an efficient reactor.

Keywords: Carbon capture and utilization (CCU), Microbial electrosynthesis (MES), Normalization, value added chemicals, optimization

Experimental optimization of long chain fatty acids synthesis from CO₂ using statistical design

Narnepati Krishna Chaitanya¹, Thulluru Lakshmi Pathi², Pritha Chatterjee^{1,2,*}

¹ Department of Civil Engineering, Indian Institute of Technology Hyderabad, Kandi, Sangareddy, Telangana, India - 502285

² Department of Climate Change, Indian Institute of technology Hyderabad, Kandi, Sangareddy, Telangana, India, 502285

*Email: Pritha@ce.iith.ac.in

CO₂ emissions contributes to global warming. Biological CO₂ fixation methods using microbes as catalysts are less expensive compared to conventional carbon capture methods. Microbial electrosynthesis cell (MES) is an electrochemical technique in which chemolithoautotrophic electroactive microbes fix CO₂ to longer chain volatile fatty acids (VFA). The synthesis of VFAs from organic waste/wastewater requires optimization aiming to improve the MES performance for industrial feasibility. This study was conducted in serum bottles to understand individual and interdependence of factors impacting VFA synthesis. The optimized parameter values will be adopted for further MES studies. Central composite design (CCD) and response surface methodology (RSM) were used to optimize total pressure, pH and ethanol concentration for VFA synthesis from synthetic wastewater in a fed batch reactor process. Enrichment of cultures was done using CO₂:H₂ gas (20:80, v/v). The optimum condition obtained from RSM was 1.11 atm pressure, pH of 7.149 and ethanol concentration 4639 mg/L. The rates of total VFA production obtained from the experimental study was 38.12 mg L⁻¹ d⁻¹ under this optimized condition, which agreed with the predicted value of 35 mg L⁻¹ d⁻¹.

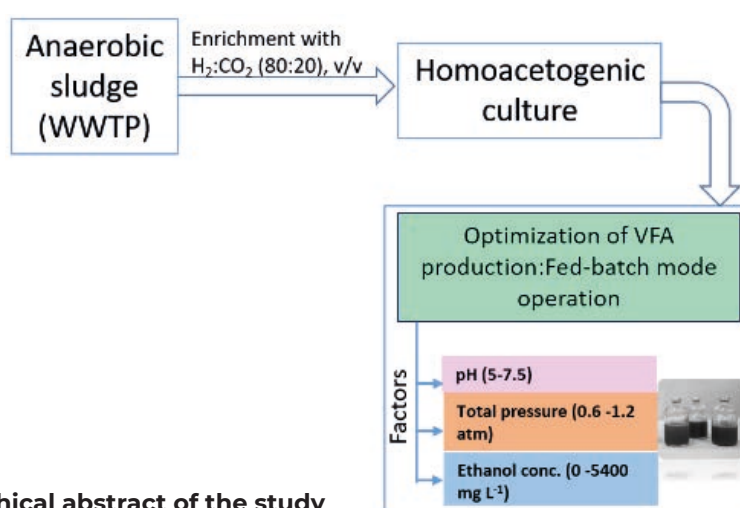

Fig. 1 Graphical abstract of the study

Keywords: Total pressure, Ethanol concentration, Response surface methodology, Optimization, Long chain fatty acids

Funding: Science and Engineering Research Board (SERB) (SRG/2019/000757 Dated 10.12.2019)

Voleu crear models per fer una drecera? Development of a model for microbial electrosynthesis with planktonic cells and mediator based electron transfer

Johannes Nelles¹, Steffi Hunger¹, Luis F. M. Rosa¹, Cristian Picioreanu², Beate Strehlitz¹, Falk Harnisch^{*}

¹ Helmholtz Zentrum für Umweltforschung GmbH, 04318 Leipzig

² TU Delft, Van der Maasweg 9, 2629, Delft

*Email: falk.harnisch@ufz.de

Despite many functional systems, reactors for microbial electrochemical technologies are mostly made by individual laboratories for their respective processes. They are hardly scalable and optimised, thus there is a lack of comparability among processes and scales [1–4]. Reactor infrastructure and aligned reactor and process models are required, that jointly enable rapid process development across scales, especially for microbial electrosynthesis (MES). As an initial step, an exemplary MES process model, the OD model presented in this contribution, describes the synthesis of chiral alcohols from ketones using planktonic cells and mediator based electron transfer. It is implemented in COMSOL Multiphysics and tested against different experimental setups and scales. Model input parameters were gathered from previous publications [5] or optimised via partial-least-square-analysis. For validation, different input parameter combinations were modelled and compared to experimental parameter values [6]. The process model properly predicts the experimental output for different input parameter combinations on the 250 mL H-cell and for a 1 L batch and fed-batch process using CSTR-based electrobioreactors [7]. Thus, a model generated from one dataset on small scale (H-cell) can successfully predict output parameters of up-scaled (CSTR) setups, qualifying it as a tool for further work in analysis and engineering of similar MES processes.

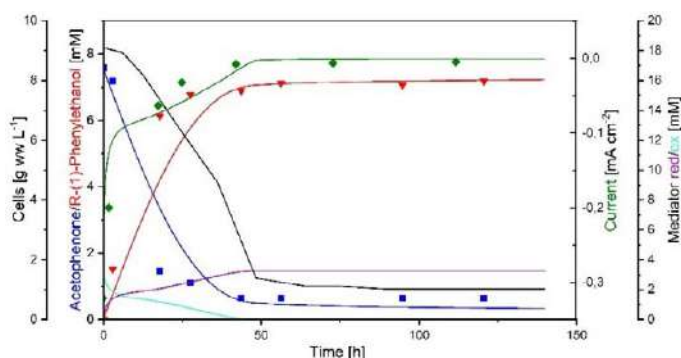

Fig. 1: Modelling of the batch 250 mL H-cell experiment published in Mayr et al. [6]. Concentration of Acetophenone (blue) and R-phenylethanol (red), reduced methyl viologene (MV, pink), oxidised MV (turquoise) in mM, current in mA (green) and cell concentration (black) in g L⁻¹ over time. Curves represent the modelling results; symbols represent the experimental results; Initial Acetophenone concentration 7.58 mM; 8.97 g L⁻¹ E. coli JG622_LbADH; 3.26 mM MV; TEA buffer (pH 7.5); potential: -503 mV vs SHE; electrode surface area: 39.27 cm². Experimental values are averaged and calculated from three independent biological replicates shown in Mayr et al. [6].

Keywords: Scaling, electrobioreactors, modelling, electrobiosynthesis, Power-to-X

Funding: This work was supported by the Helmholtz-Association in the frame of the Integration Platform “Tapping nature’s potential for sustainable production and a healthy environment” at the UFZ.

References

[1] Brown, R.K., et al., Evaluating the effects of scaling up on the performance

of bioelectrochemical systems using a technical scale microbial electrolysis cell. *Bioresour. Technol.* 2014, 163, 206–213.

[2] Heidrich, E.S., et al., Performance of a pilot scale microbial electrolysis cell fed on domestic wastewater at ambient temperatures for a 12month period. *Bioresour. Technol.* 2014, 173, 87–95.

[3] Harnisch, F., Rosa, et al., Electrifying white biotechnology: Engineering and economic potential of electricity-driven bio-production. *ChemSusChem* 2015, 8, 758–766.

[4] Holtmann, D., et al., Bioelektrochemische Syntheseverfahren. 2013, 577–580.

[5] Mayr, J.C., et al., Resting *Escherichia coli* as Chassis for Microbial Electrosynthesis: Production of Chiral Alcohols. *ChemSusChem* 2019, 12, 1631–1634

[6] Mayr, J.C., et al., Harnisch, F., Spiess, A.C., Response-Surface-Optimized and Scaled-Up Microbial Electrosynthesis of Chiral Alcohols. *ChemSusChem* 2020, 13, 1808–1816.

[7] Rosa, L.F.M., et al., Integrating Electrochemistry Into Bioreactors: Effect of the Upgrade Kit on Mass Transfer, Mixing Time and Sterilizability. *Front. Energy Res.* 2019, 7, 1–11.

Insights in the electro-fermentation process with ¹³C-labelled experiments supported by NMR spectroscopy analysis

Gaia Salvatori¹, Fabio Sciubba^{1,2}, Ottavia Giampaoli^{1,2}, Angela Marchetti¹, Alfredo Miccheli^{2,3}, Mauro Majone¹, Marianna Villano^{1*}

¹ Department of Chemistry, Sapienza University of Rome, P.le Aldo Moro 5, 00185 Rome (Italy)

² NMR-Based Metabolomics Laboratory, Sapienza University of Rome, P.le Aldo Moro 5, 00185 Rome (Italy)

³ Department of Environmental Biology, Sapienza University of Rome, P.le Aldo Moro 5, 00185 Rome (Italy)

*Email: marianna.villano@uniroma1.it

The electro-fermentation (EF) process is an interesting and promising approach to control the spectrum of products deriving from microbial anaerobic fermentations, in terms of both composition and concentration. In EF a polarized electrode, functioning either as an anode [1] or a cathode [2], is used to modify the intracellular redox balance so as to redirect the carbon flux towards the desired end-products. To date, however, it is still not clear whether an electron transfer between microorganisms and the electrode is involved or if the process is simply triggered by a change in the oxidation-reduction potential of the reaction medium.

Here, in order to gain a deeper understanding on the effect of the polarized electrode on the microbial metabolism, EF experiments have been performed by supplying ¹³C-labelled glucose, along with ethanol and acetate, to anaerobic mixed cultures inoculated at the cathode chamber of H-type reactors with the electrode potential controlled at -0.70 V (vs. SHE). The fermentation pattern has been tracked over time with the nuclear magnetic resonance (NMR) spectroscopy, that is the elective technique for ¹³C-labelled analysis. Parallel control tests (under identical conditions but in the absence of electrode polarization) have been carried out and compared to EF experiments.

Keywords: electro-fermentation, mixed microbial cultures, redox balance, nuclear magnetic resonance (NMR)

References

- [1] Vassilev I, et al. Anodic electro-fermentation: empowering anaerobic production processes via anodic respiration. *Biotechnology Advances*, 2021, 48: 107728.
- [2] Schievano A, et al. Electro-fermentation – merging electrochemistry with fermentation in industrial applications. *Trends in biotechnology*, 2016, 34: 866.

Power-to-algae: carbon dioxide to bio-oil in a BES-supported microalgae biorefinery

Bolognesi S.^{1,2*}, Bañeras L.³, Perona-Vico E.³, Capodaglio A.G.², Balaguer M.D.¹, Puig S.¹

¹ LEQUiA, Institute of the Environment, Universitat de Girona, Carrer Maria Aurèlia Capmany 69, Girona 17003, Spain.

² Department of Civil Engineering and Architecture, University of Pavia, Via Ferrata 3, 27100 Pavia, Italy.

³ Group of Molecular Microbial Ecology. Institute of Aquatic Ecology, Universitat de Girona, Carrer Maria Aurèlia Capmany 40, Girona 17003, Spain.

*Email s.bolognesi@udg.edu

Microbial electrosynthesis (MES) for bioelectro carbon dioxide (CO₂) recycling is an interesting and sustainable opportunity to exploit spent off gases from industrial facilities as a feedstock to be converted into valuable energy sources. In this proof-of-concept study, a bioelectrochemical system (BES) coupled with a heterotrophic microalgae reactor was used to convert acetate synthesized from CO₂ into bio-oil. Two BESs were operated in batch mode at an applied cathodic potential of -0.8 V vs SHE (standard hydrogen electrode) for 95 days. The systems reached a concentration of up to 13 g L⁻¹ of acetate (at a maximum production rate of 21.2 g m⁻² d⁻¹). In a second stage, the effluents from the biocathodes were transferred to microalgae reactors containing *Auxenochlorella protothecoides* to assess oil production. Bio-oil content obtained was up to 25% w/w (dry weight), enough to encourage further exploration of microalgae-to-oil recovery in the future. The overall balance resulted in 0.207 kg bio-oil per kg acetate produced, corresponding to 0.03 kg bio-oil per kgCO₂ captured, that can be further processed to produce an EU biodiesel requirement compatible bio-oil. Altogether, this research provides new alternatives to improve overall MES economic balance through the direct integration with microalgae biorefinery.

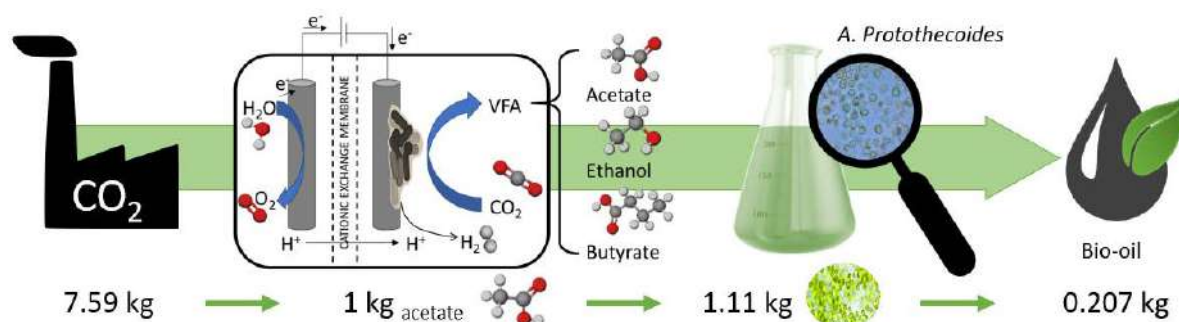

Fig. 1 – Schematic of the combined BES-microalgae biorefinery process.

Keywords: Microbial electrosynthesis, Biodiesel, *Auxenochlorella protothecoides*, Acetate production, Biocathode.

Funding: This research was funded by the Spanish Ministry of Science through the grant RTI2018-098360-B-I00 and the Agency for Business Competitiveness of the Government of Catalonia (ACCIÓ) through the DigesTake Project (COMRD116-1-0061). S.P. is a Serra Hünter Fellow (UdG-AG- 575) and acknowledges the funding from the ICREA Acadèmia award.

Characterization of fluidized vs. fixed granular activated carbon beds as cathodes for microbial electrosynthesis of carboxylates from CO₂

Igor Vassilev^{1*}, Marika Kokko¹

¹ Tampere University, Korkeakoulunkatu 8, 33720 Tampere, Finland

*Email: igor.vassilev@tuni.fi

Microbial electrosynthesis (MES) is a promising green biotechnology, which can use renewable electrical energy to drive the microbial conversion of the greenhouse gas carbon dioxide (CO₂) into value-added multi-carbon products [1]. To achieve high production rates in MES it is crucial to consider how the microorganisms can be sufficiently supplied with nutrients, CO₂ and reducing power. Therefore, the cathode material and its configuration play a key role in the optimization of MES systems.

Granular activated carbon (GAC) is an attractive cathode material due to its high biocompatibility, conductivity and high specific surface area [2]. In addition, the fluidization of the GAC bed may improve mixing and mass transfer and result in the enhanced conversion of CO₂ into multi-carbon products.

Therefore, the authors compared fluidized with fixed GAC bed cathodes for MES of acetate from CO₂ and observed clear differences in acetate production rates and biofilm formation between the different GAC bed configurations.

One of the challenges MES research needs to face is the efficient scale-up of the technology. In this regard, fluidized bed cathodes can be a promising possibility to bring MES one step closer to real-world applications.

Keywords: Fluidized bed reactor, microbial electrosynthesis, granular activated carbon bed electrodes, cathodic biofilms, mass transfer.

Funding: This research was supported by the Academy of Finland (grants no. 316657 and 319910).

References

- [1] I. Vassilev *et al.*, "Microbial Electrosynthesis of Isobutyric, Butyric, Caproic Acids, and Corresponding Alcohols from Carbon Dioxide," *ACS Sustainable Chemistry and Engineering*, vol. 6, no. 7, pp. 8485–8493, 2018, doi: 10.1021/acssuschemeng.8b00739.
- [2] J. R. Quejigoc *et al.*, "Bed electrodes in microbial electrochemistry: setup, operation and characterization," *ChemTexts*, vol. 5, p. 4, 2019, doi: 10.1007/s40828-019-0078-3.

Microbial Electrochemical Systems: Principles, Construction and Biosensing Applications

Rabeay Y. A. Hassan^{1,2,*}, Ferdinando Febbraio³ and Silvana Andreescu⁴

¹Nanoscience Program, University of Science and Technology (UST), Zewail City of Science and Technology, 6th October City, Giza 12578, Egypt

²National Research Centre (NRC), Applied Organic Chemistry Department, El Bohouth st., Dokki, Giza 12622, Egypt

³Institute of Biochemistry and Cell Biology, National Research Council (CNR), Via P. Castellino 111, 80131 Naples, Italy

⁴Department of Chemistry and Biomolecular Science, Clarkson University, Potsdam, NY 13699-5810, USA

*Email ryounes@zewailcity.edu.eg

Microbial electrochemical systems are a fast emerging technology that use microorganisms to harvest the chemical energy from bioorganic materials to produce electrical power. Due to their flexibility and the wide variety of materials that can be used as a source, these devices show promise for applications in many fields including energy, environment and sensing. Microbial electrochemical systems rely on the integration of microbial cells, bioelectrochemistry, material science and electrochemical technologies to achieve effective conversion of the chemical energy stored in organic materials into electrical power. Therefore, the interaction between microorganisms and electrodes and their operation at physiological important potentials are critical for their development. This article provides an overview of the principles and applications of microbial electrochemical systems, their development status and potential for implementation in the biosensing field. It also provides a discussion of the recent developments in the selection of electrode materials to improve electron transfer using nanomaterials along with challenges for achieving practical implementation, and examples of applications in the biosensing field

Keywords: Microbial electrochemical systems; Bioelectrochemistry; Biosensing devices; Electrode materials; electron transfer

Insights into electro-fermentation of caproate from CO₂ and ethanol

Laura Rovira-Alsina, M. Dolores Balaguer and Sebastià Puig*

LEQUiA, Institute of the Environment, University of Girona, Campus Montilivi, C/Maria Aurelià Capmany, 69, E-17003 Girona, Catalonia, Spain

*Email: laura.roviraalsina@udg.edu

Although the thermodynamics of bioelectrochemical systems is fundamentally deterministic, the end-products spectrum can be unpredictable when dealing with ever-changing circumstances. Two methacrylate bioreactors were set-up, inoculated with an open culture and fed with CO₂ and ethanol for simultaneous microbial electrosynthesis and chain elongation to valuable compounds¹ and the resulting legislative pressure is pushing the chemical and energy industries away from fossil fuels. Microbial electrosynthesis (MES. pH was adjusted to 7 and acetate to ethanol molar ratio was set at 1:1. In the first batch, mainly acetate was produced until enough butyrate was accumulated to trigger caproate formation (Fig.1). In the second batch, samples were taken at irregular time intervals to decipher the different chain elongation phases. This could have modified the thermodynamics towards caproate, but also hinted the fluctuation of organics from C1 to C8 depending on the time elapsed between sampling and feeding points. Maximum caproate production rate, titer and selectivity were 14,3 g·m⁻²·d⁻¹, 4,8 g·L⁻¹ and 36%, respectively. In the third batch, when samples were taken regularly again, only acetate production was observed. Nutrient depletion was avoided by adding a concentrated mineral solution and the maximum undissociated caproic acid content (4mM) was considered non inhibitory². Thereby, this study provides insight into key operational parameters influencing the bioreactor's dynamics that may exhibit intermediates formation of more reduced compounds.

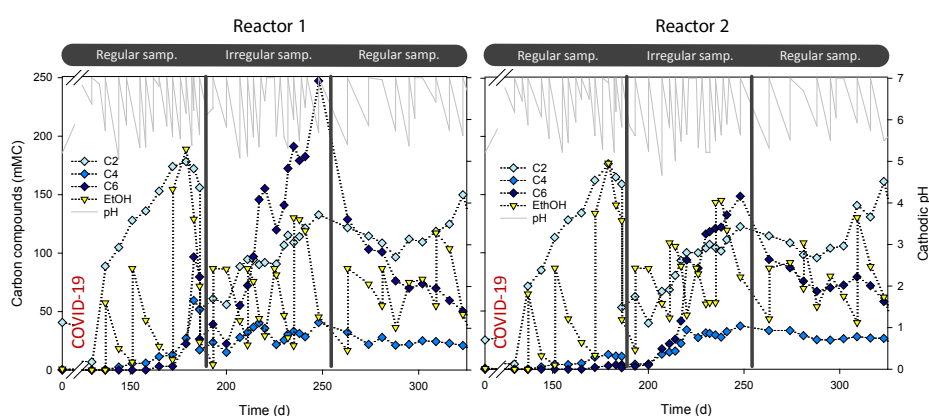

Figure 1. Organic compounds evolution and pH over time of two bioelectrochemical reactors.

Keywords: Bioelectrocatalysis, carboxylate platform, chain elongation, CO₂ valorisation, open culture.

Funding: Catalan Government (2018 FI-B 00347) in the European FSE program (CCI 2014ES05SFOP007)

References

1 P. Dessi, L. Rovira-Alsina, C. Sánchez, G. K. Dinesh, W. Tong, P. Chat-

terjee, M. Tedesco, P. Farràs, H. M. V. Hamelers and S. Puig, *Biotechnol. Adv.*, 2020, 107675.

2 S.-L. Wu, J. Sun, C. Xueming, W. Wei, L. Song, X. Dai and B.-J. Ni, *Water*, 2020, 169, 115218.

Theory of transport and recovery in microbial electrosynthesis of acetate from CO₂

Jouke Dykstra^{1*}, Annemiek ter Heijne, Sebastià Puig², Maarten Biesheuvel³

Environmental Technology, Wageningen University, P.O. Box 17, Wageningen, the Netherlands Laboratory of Chemical and Environmental Engineering (LEQUiA), Institute of the Environment, University of Girona, Carrer Maria Aurèlia Capmany, 69, E-17003 Girona, Spain

Wetsus, European Centre of Excellence for Sustainable Water Technology, Oostergoweg 9, Leeuwarden, the Netherlands

*Email: Jouke.Dykstra@wur.nl

Microbial electrosynthesis (MES) provides a route for the conversion of CO₂ into acetate and other organics. The conversion of CO₂ takes place at the biocathode. Since both charged and uncharged species participate in the reaction, understanding the transport of these species through the ion exchange membrane, is of key importance. We develop a theory for ion transport and conversion, which includes ion transport, acid-base reactions, as well as electrochemical reactions at the electrodes. We first analyze a cell configuration including three compartments, in which the acetate recovery compartment in the middle is separated from the outer compartments by one cation exchange membrane and one anion exchange membrane, and we compare with experimental data from literature. Analysis of ion transport across the membranes revealed that acetic acid/acetate and carbonic acid/bicarbonate species were used as proton shuttles between the catholyte and the recovery compartment. We also analyzed a system including a bipolar membrane (BPM), and showed that a commonly made assumption that in BPMs the charge is carried by protons and hydroxyl ions, produced inside the BPM is not generally correct. In our calculation charge is mainly carried by bisulphate and sulphate ions in the anion exchange layer of the BPM.

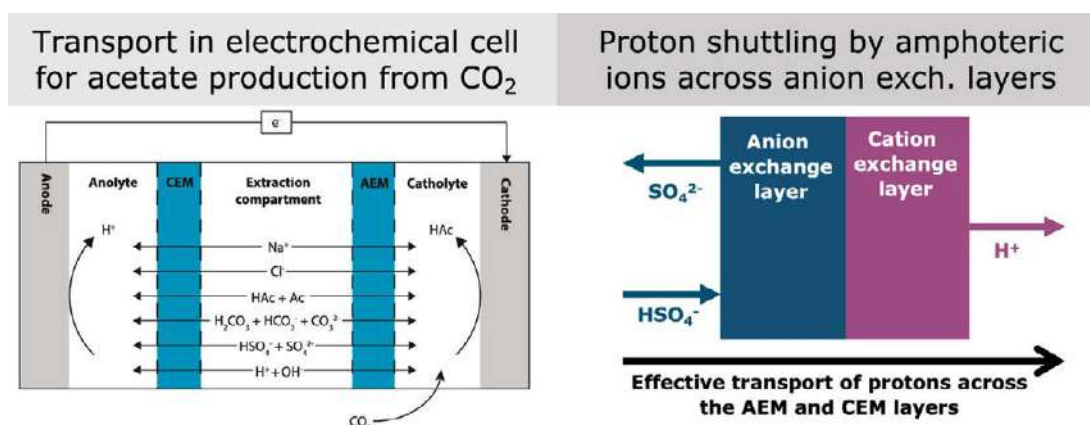

Keywords: bio-electrochemical systems, multi-component mass transport, amphoteric ions, ion exchange membranes, bipolar membranes.

Screening for hyperthermophilic electroautotrophs for the microbial electrosynthesis of organic compounds

Pillot G.^{1*}, Popall R.¹, Comes V.¹, Heussner A., Liebgott P.P.², Kerzenmacher S.¹

¹ Center for Environmental Research and Sustainable Technology (UFT), University of Bremen, 28359 Bremen, Germany

² Aix Marseille Univ., Université de Toulon, IRD, CNRS, MIO UM 110, 13288, Marseille, France

*Email: pillot@uvt.uni-bremen.de

Microbial electrosynthesis is a promising novel technology to sustainably produce organic compounds: an electrotrophic biofilm grows on a cathode, using electricity as energy source and fixing CO₂ into metabolites. The technology is so far limited by the low value of the end products. While most studies focus on the molecular engineering of model mesophilic bacteria, we aimed in this study to identify new electrotrophs from extreme environments, harboring atypical metabolisms potentially leading to new pathway for electrosynthesis. In this study, we screened 12 hyperthermophilic pure cultures and different communities from hydrothermal vents to evaluate their potential as novel electrosynthesis biocatalysts.

The experiments were performed in H-cells maintained at 75°C, with the cathode polarized at -600mV vs. SHE, in presence of different electron acceptors (NO₃⁻, SO₄²⁻, S₂O₃²⁻, FeOH, O₂ or CO₂), depending on their metabolisms. After few days of culture, the production of organic acids was analyzed by HPLC and compared to the consumption of electron acceptors and electrical current. Depending on the biocatalyst, the main products were formic, acetic, propionic, succinic, isobutyric, butyric and phenylacetic acids and glycerol from 0.16 to 1.59 mg·day⁻¹·cm⁻³. The biofilms obtained at the end of each experiment were characterized by Microscopy, qPCR, and Metabarcoding.

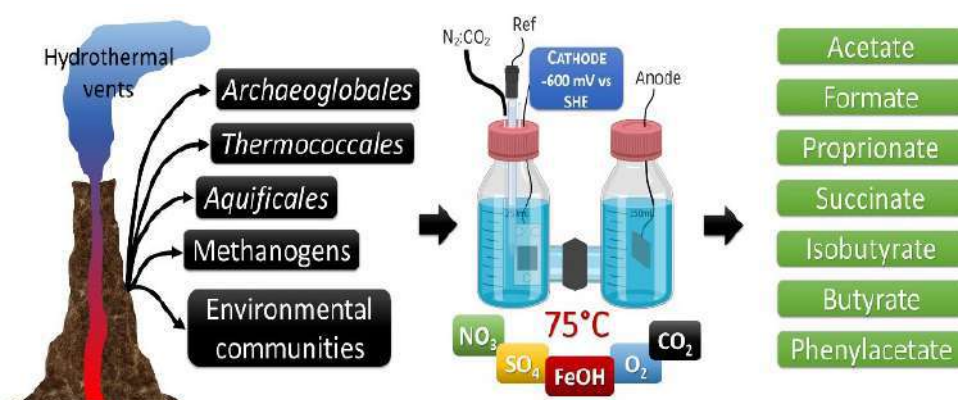

Fig. 1: Schematic of our approach to screen for hyperthermophilic electroautotrophs producing valuable compounds.

Keywords: electrosynthesis, hyperthermophily, electroautotrophs, hydrothermal vents

Biophotovoltaics for hydrogen production using cyanobacteria

Bin Lai ^{1,*}, Hans Schneider ¹, Maximillian Feußner ¹,
Andreas Schmid ¹, Jens O. Krömer ¹

¹ Department of Solar Materials, Helmholtz Centre for Environmental Research – UFZ, 04318 Leipzig, Germany

*Email: bin.lai@ufz.de

Hydrogen plays a critical role in decarbonizing our industry. Biophotovoltaics (BPV) provides a unique carbon-sink solution for bio-hydrogen production in terms of resource and energy efficiency. Water is split by oxygenic cyanobacteria using light in anode chamber and the released electrons are transferred to the cathode to reduce protons into hydrogen. CO₂ is the sole carbon source for biomass maintenance. Despite the distinguished features, BPV is still poorly understood, and the typical diverse operating parameters and the miniaturized scale of reported BPV systems hinder systemic understanding and rational optimization.

Here we present the first technical-scale BPV system with optimized and defined parameters[1]. Long-term reproducible light-dependent current output of *Synechocystis* sp PCC6803 (hereafter *Synechocystis*) was demonstrated by systematically examining potential interfering factors with biotic and abiotic controls. While using ferricyanide as the redox mediator in the system, a specific current density of 52 $\mu\text{A}/\text{nmol}_{\text{Chla}}/\text{m}^2$ was achieved, the highest value reported so far for similar conditions. To further assess the theoretical capacity and potential constraints, a genome-scale model of *Synechocystis* was established[2]. Impacts of physical and physiological parameters on the BPV performance were simulated, including overall production capacity, extracellular electron transfer pathways, seasonal light source and biomass turnover rate, etc.

Fig. 1. The Biophotovoltaics concept for hydrogen production from water driven by sunlight (left) and representative results (right).

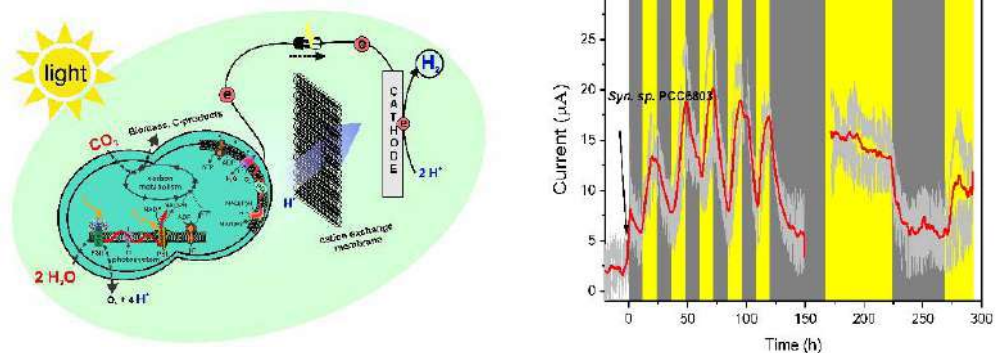

Keywords: biophotovoltaics, cyanobacteria, genome scale model, systems design, H₂ production

References

- [1]. Lai, B., et al. (2021). Technical-scale Biophotovoltaics for long-term photo-current generation from *Synechocystis* sp. PCC6803. Biotechnol Bioeng. Accepted Manuscript. <https://doi.org/10.1002/bit.27784>
- [2]. Feußner, M. (2020). A genome-scale metabolic reconstruction of *Synechocystis* PCC6803. Faculty of Mathematics and Computer Science, University of Leipzig, Germany. Master thesis (Supervisors: Dr. Jens Krömer, Dr. Bin Lai).

Electrifying biotrickling filters for the treatment of aquaponics wastewater

Narcís Pous^{1*}, Benjamin Korth², Miguel Osset-Álvarez¹, M. Dolors Balaguer¹, Falk Harnisch², Sebastià Puig¹

¹ Laboratory of Chemical and Environmental Engineering (LEQUIA), Institute of the Environment, University of Girona, Carrer Maria Aurèlia Capmany, 69, E-17003, Girona, Spain

² Department of Environmental Microbiology, Helmholtz-Centre for Environmental Research – UFZ, Permoser Str. 15, 04318, Leipzig, Germany

*Email: narcis.pous@lequia.udg.cat

The combination of aquaculture (fish farming) and hydroponics (soilless plant cultivation) is a promising method for providing food while reducing the environmental impacts of the individual peers (i.e. water consumption, nitrogen loads, land use). However, ammonium-rich aquaculture effluents cannot be directly used for hydroponics, which requires almost ammonium-free water but with a certain amount of nitrate as nutrient (1 - 34 mgN·L⁻¹). Thus, for aquaponics a system providing full nitrification and a controlled denitrification is required. For this reason, this work explored the potential of biotrickling filters (i.e. common aquaculture depuration technology) to be electrified for improving nitrification/denitrification rates and provide a tuneable denitrification by means of Microbial Electrochemical Technologies (MET).

Four different easy-to-assemble and easy-to-use designs were tested¹. The highest ammonium and nitrate removal rates (94 gN·m⁻³·d⁻¹ and 43 gN·m⁻³·d⁻¹, respectively) were reached by combining an aerobic non-conductive zone with an electrified anoxic zone (Fig.1). The effluent criteria for an aquaponics application was reached at low energy cost (8.3 × 10⁻² kWh·gN⁻¹) without neither external aeration nor addition of chemicals. Electrified biotrickling filters have demonstrated to be promising sustainable alternative for aquaponics and potentially for the treatment for organic carbon-deficient ammonium-contaminated waters.

Fig. 1 Introduction of an electrified biotrickling filter in an aquaponics loop

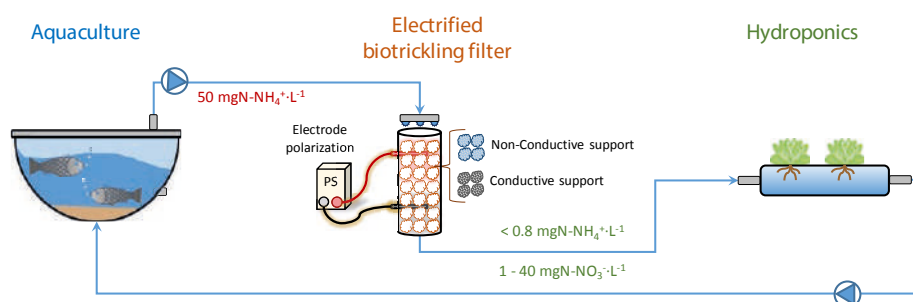

Keywords: Circular bioeconomy, Bioelectrochemical nitrogen removal, Biocathode, Blue economy, Power-to-food.

Funding: This research was carried out in the Project “Wireless Aquaponic Farming in Remote Areas: A smart adaptive socio-economic solution” (WAFRA)

funded within the 7th Framework Program (ERANETMED) by the Spanish Ministry of Science (PCI2018-092946) and the German Federal Ministry of Education and Research (BMBF) (01DH18003). S.P. is a Serra Hunter Fellow (UdG-AG-575) and acknowledges the funding from the ICREA Academia award.

References

- [1] Pous, M., Korth, B., Osset-Álvarez, M., Balaguer, M.D., Harnisch, F., Puig, S. Electrifying biotrickling filters for the treatment of aquaponics wastewater. *Bioresour. Technol.* 2021, 319 (3), 124221.

Metabolic Pathway Involved in CO₂ Fixation under Photo-Bioelectrochemical conditions by a Purple Phototrophic Bacteria Biofilm

S. Díaz-Rullo Edreira^{1*}, JJ. Espada², R. Wattiez³, B. Leroy³, F. Martínez¹, D. Puyol¹

¹ Department of Chemical and Environmental Technology, ESCET, Universidad Rey Juan Carlos, Móstoles, 28933 Madrid, Spain

² Department of Chemical, Energy and Mechanical Technology, ESCET, Universidad Rey Juan Carlos, Móstoles, 28933 Madrid, Spain

³ Laboratory of Proteomics and Microbiology, Research Institute for Biosciences, University of Mons, Mons, Belgium

*Email sara.diazrullo@urjc.es

Bioelectrochemical systems are a promising technology to treat wastewater and fix CO₂ via electrosynthesis [1]. We demonstrated in previous work the capacity of a mixed biofilm of purple phototrophic bacteria (PPB) to degrade organic matter and fix CO₂ under electrochemical conditions [2]. However, the specific metabolic pathway involved in this process is still not known. In this work, we explore it through a comprehensive analysis by metaproteomics and MiSeq 16S-rRNA gen sequencing analysis of different samples of a cathodic mixed biofilm grown under irradiation and different voltages (0, -0.2, -0.4, and -0.8V vs. Ag/AgCl) and dark conditions at non-voltage.

Preliminary results show an inverse correlation between chemical oxygen demand and CO₂ consumption rates (Fig 1a), suggesting that the negative polarization enhances the use of CO₂ for the PPB growing instead of organic carbon. The results from MiSeq analysis (Fig 1b) show that the polarization of the cathode strongly enhances the growth of PPB. It also suggests a synergic relationship between different genus of PPB and genus *Wolinella*, which may be related to direct interspecies electron transfer. The metaproteomics analysis will explain whether the electron target reaction responsible for the CO₂ fixation process is anaplerotic or belongs to the Calvin cycle.

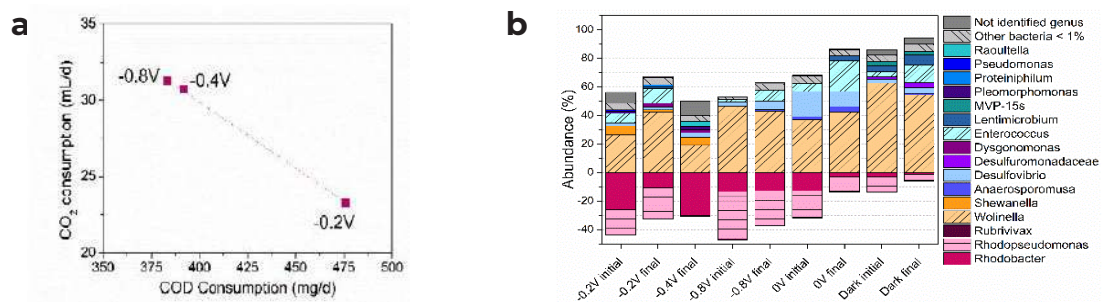

Fig. 1 (a) Correlation between CO₂ and chemical oxygen demand (COD) consumption rates and (b) percent-age of different genera that form part of the biofilm from BES.

Keywords: Bioelectrochemical, purple phototrophic bacteria, carbon dioxide

Funding: FOTOBIOELECTRO (CTM2017-91186-EXP), REMTAVARES-CM (S2018/EMT-4341), BIOTRES-CM (S2018/EMT-4344) and R&D Young Researchers Fund 2019 (SUN-BIOELECTROMAT) projects, and Ramon y Cajal grant. The bioprofiling platform used for the proteomic analysis was supported by the European Regional Development Fund and the Walloon Region, Belgium. B. Leroy work was supported by the FNRS under the CDR project "Redox homeostasis in purple bacteria"

References

- [1] Logan & Rabaey, Conversion of wastes into bioelectricity and chemicals by using microbial electrochemical technologies, Science 2012. 337 686–690.
- [2] S. Díaz-Rullo Edreira et al., Assessment of voltage influence in carbon dioxide fixation process by a photo-bioelectrochemical system under photoheterotrophy, Microorganisms. 2021 9 1–8.

Hyperthermophilic hydrogen production by iron reducing Archaea in microbial electrolysis cells (MECs)

Aykut Kas, Yasemin Dilsad Yilmazel*

Department of Environmental Engineering, Middle East Technical University, Ankara Turkey, 06800

*Email: dilsad@metu.edu.tr

Utilization of (hyper)thermophilic microorganisms was suggested to improve reaction rates and insoluble pollutant degradations and minimize risk of contamination in bioelectrochemical systems. Only a small group of hyperthermophilic microorganisms were identified with the ability to produce current in such systems and here we present a new culture that fits to this description. This iron reducing archaeal culture originally isolated from a hydrothermal structure, produced $1.53 \text{ A/m}^2 \pm 0.24$ current density in MECs operated at 80°C . Hydrogen production rate was found as $0.50 \pm 0.09 \text{ mL H}_2 / \text{mL active volume}$ in the 5 mL Mini-MEC reactors fed with 10mM acetate. Resulting current density is 2.5 – 3 times higher than the previously reported electro-active behaviour of closely related archaeal species of *F. placidus* and *G. ahangari* with the exact reactor configuration. There was a visible biofilm formation on the anode and 6 cycles of biohydrogen generation coupled with current generation was measured. After 6th cycle biofilm started to peel from the electrode surface and both hydrogen and current generations were decreased. Cyclic voltammetry (CV) analysis produced a sigmoidal catalytic wave with a mid-point potential of -0.35 V (vs. Ag/AgCl) and Scanning Electron Microscopy showed thick biofilm with multiple layers of cells.

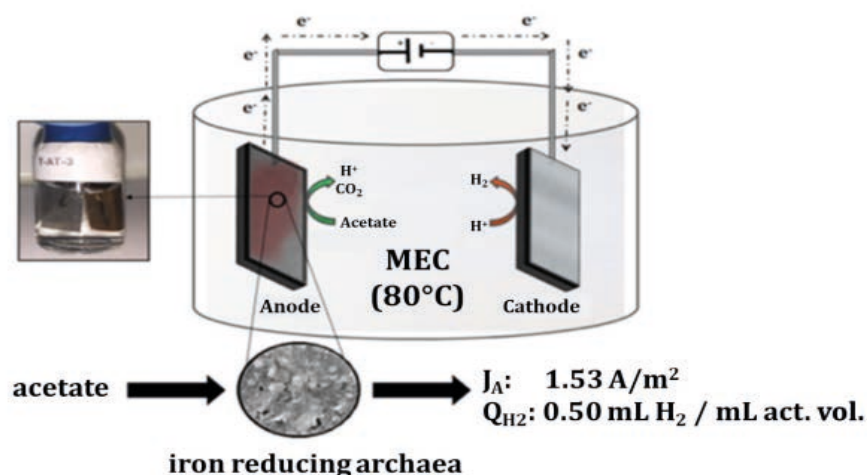

Fig. 1 Iron reducing archaeal culture in microbial electrolysis cell (MEC) operated at 80°C

Keywords: iron reducing archaea, hyperthermophilic, microbial electrolysis cells, biohydrogen

This study was funded by The Scientific and Technological Research Council of Turkey (TUBITAK) grant no 119C011.

Alliance of microbial electrochemical technologies and fermentation for the conversion of carbon dioxide into elongated chemical building blocks

Romans-Casas, M.^{1,*}, Blasco-Gómez, R.¹, Colprim, J.¹, Balaguer, M.D.¹, Puig, S.¹

¹ Laboratory of Chemical and Environmental Engineering (LEQUIA), Institute of the Environment; University of Girona, Campus Montilivi. C/Maria Aurèlia Capmany, 69. E-Facultat de Ciències, E-17003 Girona, Catalonia, Spain

*Email: meritxell.romans@udg.edu

This work presents the combination of microbial electrochemical technologies and fermentation in a two-step process for the electro-bioconversion of carbon dioxide (CO₂) into elongated organic compounds. The electro bio-reduction of CO₂ was coupled to an elongation fermentative step. Key parameters considered in the first step were pH, hydrogen and CO₂ partial pressures [1,2]. Concerning the second step, selected parameters were pH, ethanol to acetate ratio, and hydrogen availability. The first step reached an ethanol to acetic acid (EtOH:HAc) ratio above 1-to-1 when fed with CO₂, under pH around 5.3 in an H₂-mediated microbial electrosynthesis. Formed products allowed the follow-up chain elongation processes. The fermentation step reached up to C₆ compounds at pH 7.0, when fed with EtOH:HAc 3:1 or 1:1, CO₂ and H₂. Outcomes demonstrated that pH was a crucial factor throughout the process. Elongation conversion efficiencies were above 80 % in all studied conditions. The overall process carbon conversion efficiency, when fed with EtOH:HAc 1:1, was 38 % being the limiting step of the bio-electro CO₂ transformation. These results pave the ground to selective production of reduced commodity chemicals from CO₂ and electricity.

Fig. 1 Schematic representation of the proposed platform.

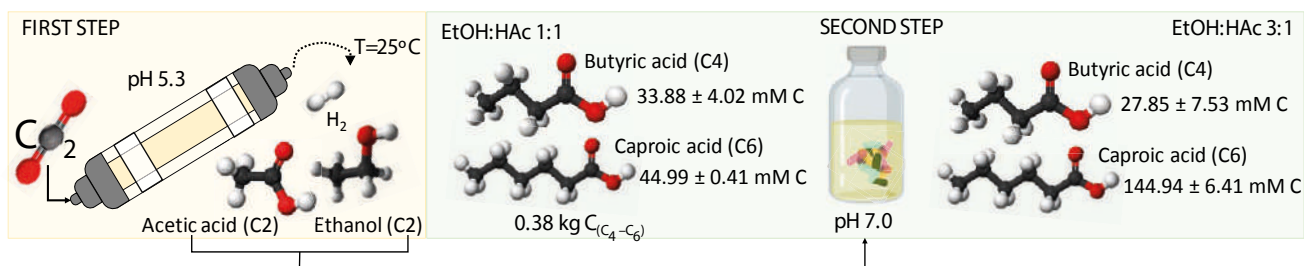

Keywords: Chain elongation; CO₂ valorisation; electrochemistry; gas fermentation; solventogenesis

Funding: The authors acknowledge the funding from the Agency for Business Competitiveness of the Government of Catalonia (ACCIÓ; COMRDI16-1-0061) and the Spanish Ministry of Science (RTI2018-098360-B-I00). M.R.-C. is grateful

for the support of the Catalan Government (2021 FI_B 00499). S.P. is a Serra Hunter Fellow (UdG-AG-575) and acknowledges the funding from the ICREA Academia award.

References

[1] Blasco-Gómez R, et al. Unravelling the factors that influence the bio-electrorecycling of

carbon dioxide towards biofuels. *Green Chemistry*, 2019, 21: 684-691.

[2] Blasco-Gómez R, et al. Steering bio-electro recycling of carbon dioxide towards target compounds through novel inoculation and feeding strategies. *Journal of Environmental Chemical Engineering*, 9: 105549.

3D bioprinted MES biofilms enhancing the acetate production rate of *Sporomusa ovata*

Adolf Krige¹✉Ulrika Rova¹Paul Christakopoulos¹

¹ Biochemical Process Engineering, Division of Chemical Engineering, Department of Civil, Environmental and Natural Resources Engineering, Luleå University of Technology, SE-971 87 Luleå, Sweden

*Email: adolf.krige@ltu.se

Microbial Electrosynthesis (MES) is an emerging and promising technology for carbon capture and utilization. Achieving highly efficient electron transfer from the cathode to microbes is, however, one of the main challenges hindering the development of MES reactors. It is, therefore, essential to improve biofilm growth for direct electron uptake-based bioconversions^{1,2} although a techno-economic-driven roadmap towards validation and large-scale demonstration of the technology is lacking. In this work, two main integrated systems were modelled, centered on (1. Here we show the use of 3D bioprinting for MES systems, creating a “synthetic biofilm”, containing *Sporomusa ovata*. The synthetic biofilm greatly improves the acetate production rate while drastically decreasing start-up time. By bioprinting on a carbon cloth electrode, we obtained an average acetate productivity of $3156 \pm 338 \text{ mMday}^{-1} \text{ m}^{-2}$ ($5.12 \pm 0.55 \text{ mMday}^{-1}$) when poised at $-0.8 \text{ V vs Ag/AgCl}$. This is an order of magnitude higher than typical *S. ovata* production rates. Furthermore, a high production rate was achieved almost directly after the start-up (± 40 hours) without requiring media exchanges. Cyclic voltammetry data showed similar current densities, much higher potentials than in the control reactors, (achieving similar currents at approx. 300 mV higher than the controls). Improved growth of *S. ovata* cells at the cathode surface and throughout the gel was shown using SEM imaging and fluorescent microscopy, supporting an increased electron transfer efficiency and potentially improving the bio-catalyzation of H_2 .

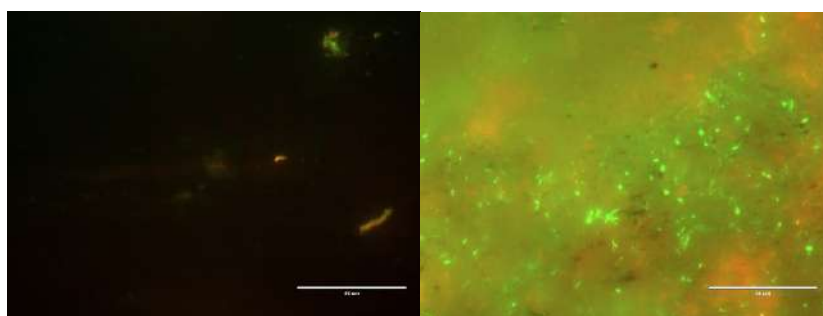

Bioprinted

Control

Fig. 1 Acetate production and “Live/Dead” fluorescent microscopy images of MES reactors using 3D bio-printed “synthetic biofilm” cathodes compared to MES cells using suspended cell inoculums as a control

Keywords: Bioprint; biofilm; *S. ovata*; microbial electrosynthesis; bioelectrochemical

Funding: Swedish Research Council (VR), (No. 2018-03875)

References

- [1] Jourdin L, et al. Techno-Economic Assessment of Microbial Electrosynthesis from CO_2 and/or Organics: An Interdisciplinary Roadmap towards Future Research and Application. *Appl. Energy* 2020, 279, 115775.
- [2] Chen L, et al. Electrosynthesis of Acetate from CO_2 by a Highly Structured Biofilm Assembled with Reduced Graphene Oxide-Tetraethylene Pentamine. *J. Mater. Chem. A* 2016, 4 (21), 8395–8401.

Bioinorganic electrosynthesis of single-cell protein from CO₂ and green electricity

Mingyi Xu¹, Yifeng Zhang^{1,*}

¹ Department of Environmental Engineering, Technical University of Denmark, 2800 Kongens Lyngby, Denmark

*Email: yifz@env.dtu.dk

Climate change and food shortage due to the growing world population are two of the biggest challenges for the transition to a low-carbon economy in the coming decades. In this study, we propose a promising two-stage bioinorganic electrosynthesis process that can first convert CO₂ and renewable electricity into methane and then synthesize single-cell protein, as an alternative solution to address these challenges. With an external voltage of 3.5 V and a CO₂ inflow rate of 50 mL·d⁻¹, it was possible to produce methanotrophic biomass of 118.7 ± 9.2 mg·L⁻¹ with an amino acids mass-content of 54.6 ± 8.3%, resulting in nitrogen assimilation and CO₂ conversion efficiency of 91.0 ± 1.3% and 71.0%. The applied voltages, CO₂ inflow rates, and O₂ supply were found to affect the process significantly. The outcomes will lead to sustainable protein production, CO₂ mitigation, and valorization of renewable electricity, which are perfectly in line with the United Nations Sustainable Development Goals (2, 6, 7, 8, 9, 13, 14, 15).

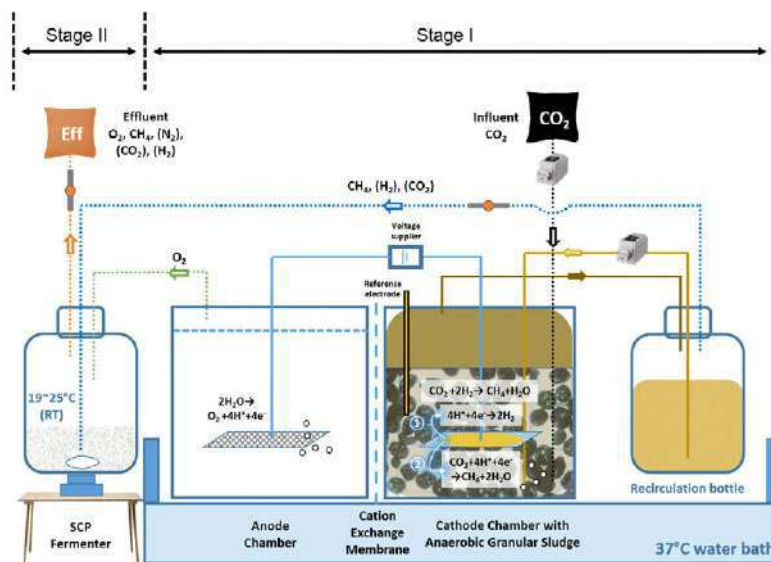

Fig. 1 Schematic illustration of the proposed BIES for SCP production

Keywords: Microbial electrosynthesis, Single-cell protein, Carbon capture and utilization, Hydrogenotrophic methanogens, Aerobic methane oxidation

Funding: the Novo Nordisk Foundation (NNF16OC0021568, Denmark)
the Carlsberg Foundation Distinguished Fellowships (CF18-0084, Denmark)
the China Scholarship Council (China)
the Otto Mønsted Fond (Denmark)

In-situ production of microbial protein with reclaimed ammonium in a microbial electrochemical recovery conversion cell

Xiaoyong Yang^{1*}, Yufeng Jiang¹, Yifeng Zhang¹

¹ Department of Environmental Engineering, Technical University of Denmark, Lyngby, Denmark, DK-2800

*Email: xyan@env.dtu.dk

Microbial protein (MP) is regarded as a promising alternative to plant/animal based protein to feed the world because of its low environmental impact. In-situ and cost-effectively recovery of nitrogen from wastewater is one of the key challenges to economy of MP production. We therefore proposed a two-chamber microbial electrochemical recovery conversion cell to meet the challenge. A representative MP producer, *Cupriavidus necator*, could fix carbon dioxide as protein-rich biomass in the cathode chamber with ammonium recovered from wastewater in the anode chamber through diffusion and electroosmosis and in-situ generated hydrogen and oxygen through water electrolysis. MP was successfully obtained with an external power supply of 3 ~ 5 volt and the MP yield was 0.81 g/L in 36 h at 5V in batch mode. *C. necator* could grow in cathode even when the anode chamber was filled with ammonium solution in a broad range (0.05 ~ 8 g N/L). Highest MP yield 0.9 g/L was achieved in 36 h at 2 g N/L. The system was also proved had the ability to produce MP with reclaimed ammonium from real wastewater streams (e.g., influent from municipal wastewater and digestate) and the protein yielded had a high quality on amino acid profile.

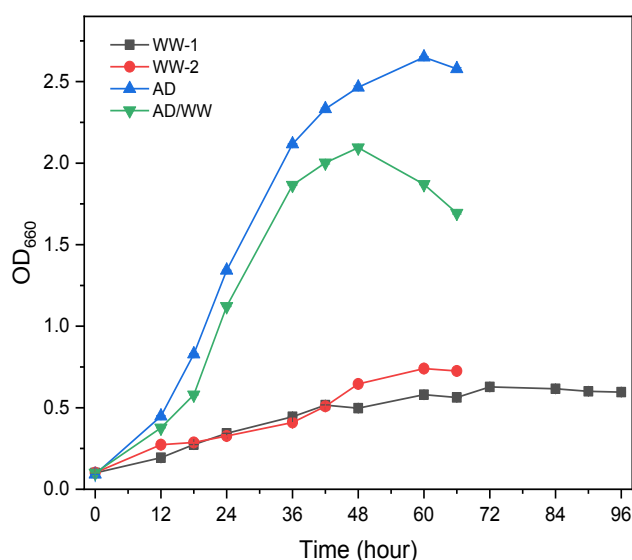

Fig. 1 *C. necator* was cultivated in the microbial electrochemical recovery conversion cell with different wastewater streams, WW, influent from a municipal wastewater, AD, digestate from an anaerobic digester, AD/WW, a mixture of the former two wastewater streams.

Keywords: single cell protein, hydrogen-oxidizing bacterium, ammonium recovery, microbial electrochemical system

Funding: This work was supported by the Novo Nordisk Foundation (NNF16OC0021568, Denmark) and the Carlsberg Foundation Distinguished Fellowships (CF18-0084, Denmark). The authors would like to acknowledge the financial support from the China Scholarship Council (China),

Towards bioelectrochemical degradation of hydrophobic wastes coupled with synthesis of biosurfactants

Grzegorz Pasternak^{1*}, Aleksander de Rosset, Natalia Tyszkiewicz, Bartosz Widera

¹ Wrocław University of Science and Technology, Laboratory of Microbial Electrochemical Systems, Department of Process Engineering and Technology of Polymer and Carbon Materials, Gdańska 7/9, 50-344 Wrocław

*Email: grzegorz.pasternak@pwr.edu.pl

In recent decades, bioelectrochemical systems (BES) have undergone significant improvements and numerous exciting applications have emerged. This technology has great potential to contribute in solving multiple global issues such as environmental contamination. There are, however, some limitations in the efficiency of treating hydrophobic wastes such as petroleum contaminants or waste cooking oil.

In our research, we aimed to couple the bioelectrochemical degradation of these substrates with *in-situ* production of biosurfactants in microbial fuel cells (MFCs) and potentiostatic–controlled BESs. Several approaches have been taken for the enrichment of microbial consortia capable of bioelectrochemical synthesis of surfactants. The microbial communities were derived from environments with various contact with hydrocarbons such as contaminated soil, municipal environments, river sediments, activated sludge, mud volcanoes, and glacier environments. Each of the communities revealed unique electrochemical properties and tolerance to petroleum hydrocarbons. The amount of biosurfactants detected in the process varied and their highest activity was reported when using waste cooking oil and external load used as a selective factor in contrary to various poised potentials, where biodegradation was accompanied with negligible changes in surface tension. The established electrofermentation led to the synthesis of biosurfactants and increased bioavailability of hydrophobic substrates for their further biodegradation.

Keywords: MFC, BES, waste, petroleum, oil, biosurfactants

Funding: This work was supported by the Polish National Agency for Academic Exchange – Polish Returns grant (PPN/PPO/2018/1/00038) and National Science Centre (Poland) OPUS grant (2019/33/B/NZ9/02774).

References

- [1] Pasternak, G., Askitosari, T. D. and Rosenbaum, M. A. (2020) 'Biosurfactants and Synthetic Surfactants in Bioelectrochemical Systems: A Mini-Review', *Frontiers in Microbiology*, 11, pp. 1–9. doi: 10.3389/fmicb.2020.00358

Biogas upgradation through CO₂ conversion into acetic acid via microbial electrosynthesis (MES)

Moumita Roy¹, Sunil A Patil^{*}

¹Department of Earth and Environmental Sciences, Indian Institute of Science Education and Research (IISER) Mohali, Knowledge City, Sector 81, SAS Nagar, 140306, Punjab, India

*Email: sunil@iisermohali.ac.in; sunilmicro12@gmail.com

Biogas is considered one of the major biofuel sources to address the issues associated with fossil-fuels through sustainable approaches. Due to the presence of CO₂ in biogas, its calorific value decreases considerably. Various biogas upgradation technologies are under intense investigation to increase the methane content to desired level [1]. In this study, we demonstrate methane content enhancement in biogas through CO₂ conversion into acetic acid via MES process. In the MES reactors inoculated with *Acetobacterium* dominated mixed culture [2], biogas was fed continuously at different flow-rates (0.5,0.3,0.2ml/min). At a fixed cathodic potential of -1 V (vs. Ag/AgCl), a considerable increase in methane content along with acetic acid production was achieved in all cases. The highest flow-rate (0.5ml/min) was found to be least effective both for methane content increase (from 61±3% to 86±2%) and acetic acid titer(2.0±0.25g/L). In comparison, the lowest flow-rate of 0.2ml/min was the most effective for the intended process (methane upgradation from 62±7% to 93±3% and acetic acid titer(3.9±0.6 g/L). The bioproduction and biogas upgradation occurred at an E_{cell} of 3.3±0.35V. The demonstrated approach offers the advantage of obtaining two products; one in the bulk phase and the other in the off-gas from the biogas feed.

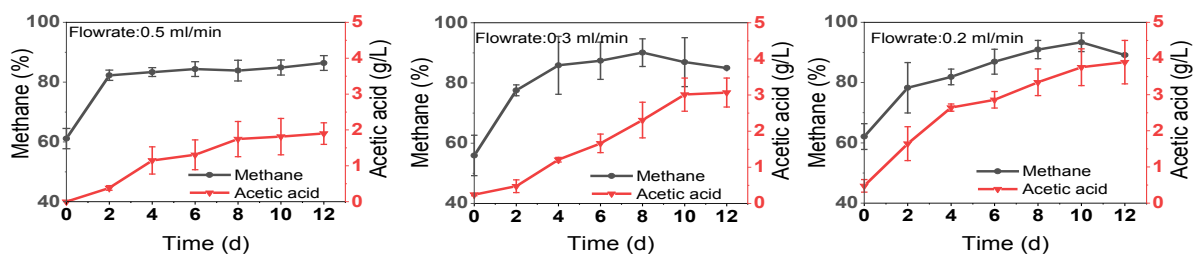

Fig.1 Methane and acetic acid concentration profiles at different flow rates of biogas.

Keywords: Biogas upgradation, Microbial electrosynthesis, *Acetobacterium*

Funding: Department of Biotechnology (DBT), Government of India (Project No. BT/PR28914/BCE/8/1441/2018)

References

- [1] Kapoor R, et al. Evaluation of biogas upgrading technologies and future perspectives: a review *Environmental Science and Pollution Research* (2019) 26:11631–11661.
- [2] Roy M, et al. Direct utilization of industrial carbon dioxide with low impurities for acetate production via microbial electrosynthesis. *Bioresource Technology* 320 (2021) 124289.

CO₂ conversion by combining a Cu electrocatalyst and microorganisms

Konstantina-Roxani Chatzipanagiotou^{1,2}, Virangni Soekhoe^{1,2}, Ludovic Jourdin^{2,3}, Cees J. N. Buisman², J. Harry Bitter^{1*}, David P. B. T. B. Strik^{2,**}

¹ Biobased Chemistry and Technology, Wageningen University & Research, Bornse Weiland 9, Wageningen, the Netherlands, 6708 WG

² Environmental Technology, Wageningen University & Research, Bornse Weiland 9, Wageningen, the Netherlands, 6708 WG

³ Currently at Department of Biotechnology, Delft University of Technology, van der Maasweg 9, Delft, the Netherlands, 2629 HZ

*Email: harry.bitter@wur.nl

**Email: david.strik@wur.nl

Electrocatalytic conversion of CO₂ can utilize renewable electricity to valorise this waste greenhouse gas. Both abiotic (e.g. metal) catalysts and microorganisms (MOs) can catalyse this reaction. Metals achieve high reaction rates, but often deactivate fast and produce short carbon chains. In microbial electrosynthesis, MOs have a lag phase, but are self-replicating, can operate for long periods and produce longer carbon chains. Based on their advantages and disadvantages, metals and MOs could complement each other if combined. Metals can produce intermediates at high rates, which can be further elongated by MOs. On the other hand, combination can result in biofouling, catalyst deactivation due to microbial growth nutrients, and/or metal toxicity to MOs.

Here, we present the first reports on combining a copper (Cu) electrocatalyst and MOs for CO₂ conversion. Microbial growth medium not only allowed, but in fact enhanced the catalytic activity of Cu for formate production, compared to buffer (Fig.1a).^[1] MOs did not hinder the catalytic activity of Cu, despite biofilm growth on the electrode (Fig.1b).^[2] MOs, evidently not toxified by Cu, were able to consume CO₂ and formate, producing acetate as final product (Fig.1c).^[2] Despite its antimicrobial properties, Cu is a promising catalyst to combine with MOs.

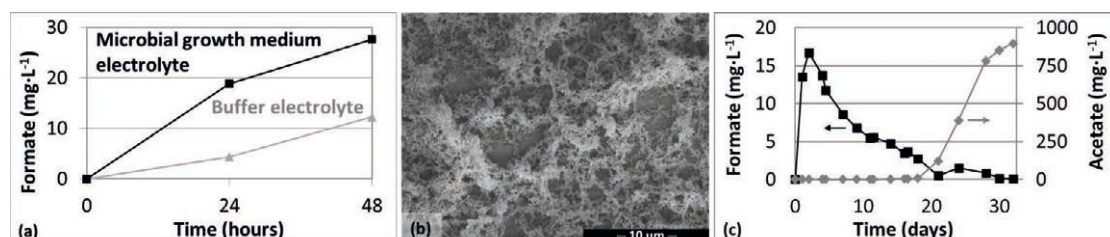

Fig. 1: (a) Electrocatalytic formate production over time with Cu electrodes in microbial growth medium (black line) and buffer (grey line) electrolytes, in the absence of MOs. (b) Biofilm growth on Cu electrode at the end of microbial electrosynthesis experiments. (c) Formate production by Cu electrode (black line, left axis) and simultaneous consumption by MOs, accompanied by acetate production by MOs (grey line, right axis).

Keywords: microbial electrosynthesis, copper electrocatalyst, CO₂ electroreduction, catalytic cooperation

Funding: Wageningen Institute for Environment and Climate

Research; Graduate School of Food Technology, Agrobiotechnology, Nutrition and Health Sciences

References

[1] Chatzipanagiotou K-R, et al. CO₂ conversion by combining a copper electrocatalyst and

wild-type microorganisms. ChemCatChem, 2020, 12: 3900.

[2] Chatzipanagiotou K-R, et al. Catalytic Cooperation between a Copper Oxide Electrocatalyst and a Microbial Community for Microbial Electrosynthesis. ChemPlusChem, in press.

Biocathode and photoanode development for solar energy-driven microbial electrosynthesis

Paolo Dessì¹*, G. Kumaravel Dinesh¹, Wenming Tong¹, Pau Farràs¹

¹ Energy Research Centre, Ryan Institute, School of Chemistry, National University of Ireland Galway, University Road, H91 TK33 Galway, Ireland

*Email: paolo.dessi@nuigalway.ie

Microbial electrosynthesis (MES) is a promising technology for CO₂ recycling into valuable products such as volatile fatty acids and alcohols [1]. However, the high capital (particularly the anode material) and operation costs (mainly electric energy consumption) are hindering its adoption in industry [2]. This study focuses on the development of a MES cell equipped with a low-cost photoanode that exploits visible light to decrease the electric power input required to drive bio-cathodic CO₂ reduction. A three-chamber hybrid cell prototype has been designed and 3-D printed for laboratory-scale experiments, where the bio-cathode and photo-anode parts are currently being optimized separately. The highest acetate production rate (53 g/m²/d, 0.85 g/L/d) was achieved in the cell equipped with a gas diffusion biocathode operated in continuous mode (100% CO₂, 2 mL/min) at room temperature under galvanostatic mode (1 mA/cm²). This resulted in an average specific production of 38.7 kg_{acetate}/MWh_{el}, highlighting the need of reducing the electric power input to make the process sustainable. Photoanodes were fabricated by deposition of a thin layer (60 μm) of BiVO₄-based photocatalyst on a fluorine tin oxide transparent electrode, achieving the highest stable photocurrent of 0.15 mA/cm² when exposed to a simulated AM1.5G solar spectrum at 1 V bias.

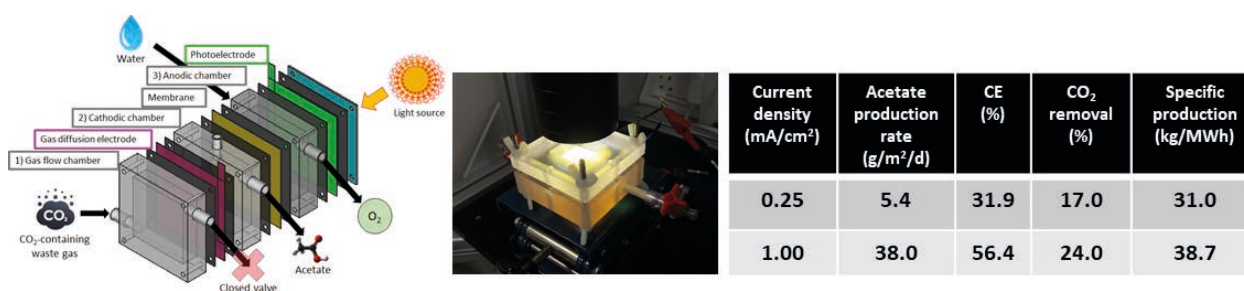

Fig. 1. From left to right: schematic overview of the hybrid cell; picture of the BiVO₄-based photocatalyst under testing; table summarizing average production rate, coulombic efficiency, CO₂ removal efficiency and specific production obtained at an applied current of 0.25 and 1.00 mA/cm².

Keywords: Bioelectrochemical system, CCU, Microbial electrosynthesis, OER, Photocatalysis

Funding: Science Foundation Ireland (SFI) Pathfinder Award on "Hybrid Bio-Solar Reactors for wastewater treatment and CO₂ recycling" (nr. 19/FIP/ZE/7572PF).

References

- [1] Dessì P, et al. Microbial electrosynthesis: Towards sustainable biorefineries for production of green chemicals from CO₂ emissions. *Biotechnology Advances*, 2021, 107675.
- [2] Jourdin L, et al. Techno-economic assessment of microbial electrosynthesis from CO₂ and/or organics: An interdisciplinary roadmap towards future research and application. *Applied Energy*, 2020, 115775.

A general model for biofilm-driven microbial electrosynthesis of carboxylates from CO₂

Oriol Cabau-Peinado¹, Adrie J.J. Straathof¹, Ludovic Jourdin^{1*}

¹ Department of Biotechnology, Faculty of Applied Sciences, Delft University of Technology, Van der Maasweg 9 - 2629 HZ, The Netherlands

*Email: L.Jourdin@tudelft.nl

Up to date, computational modelling of microbial electrosynthesis (MES) has been underexplored, but is necessary to achieve breakthrough understanding of the process-limiting steps. We developed a general framework for modelling microbial kinetics in a MES reactor. A thermodynamic approach is used to link microbial metabolism to the electrochemical reduction of an intracellular mediator, allowing to predict cellular growth and current consumption. The model accounts for CO₂ reduction to acetate, and further elongation to n-butyrate and n-caproate. Simulation results were compared with experimental data obtained from different sources and proved the model is able to successfully describe microbial kinetics (growth, chain elongation, product inhibition) and reactor performance (current density, product titre). The capacity of the model to simulate different system configurations is also shown. Model results suggest CO₂ dissolved concentration might be limiting existing MES systems, and highlight the importance of the delivery method utilized to supply it. Simulation results also indicate that for biofilm-driven reactors, continuous mode significantly enhances microbial growth and might allow denser biofilms to be formed and higher current densities to be achieved.

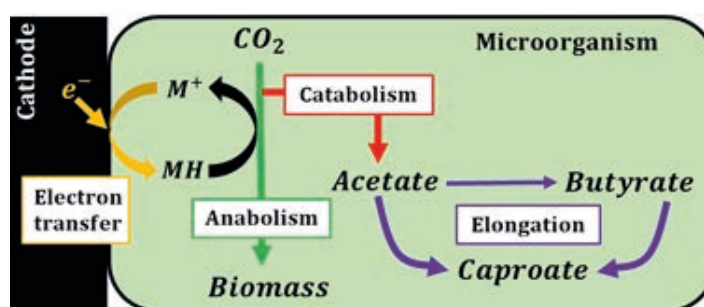

Fig. 1 Schematic representation of the modelled reactions within the microbial cell.

Keywords: Microbial electrosynthesis, Microbial kinetics, Mathematical model, CO₂ reduction, Chain elongation.

Funding: This activity is co-financed by Shell and a PPP-allowance from Top Consortia for Knowledge and Innovation (TKI's) of the Dutch Ministry of Economic Affairs and Climate in the context of the TU Delft e-Refinery Institute.

References

[1] Cabau-Peinado, O., Straathof, A. J., & Jourdin, L. (2021). A general model for biofilm-driven microbial electrosynthesis of carboxylates from CO₂. *Frontiers in Microbiology*, 12, 1405.

The impact of cathode acclimation methods on electrothrophic biofilm formation and performance of electromethanogenic cells

Amin Ghaderikia, Yasemin Dilsad Yilmazel*

Department of Environmental Engineering, Middle East Technical University, Ankara Turkey

*Email: dilsad@metu.edu.tr

In this work, we investigated the impact of changing substrate on the formation of biofilm in electromethanogenic cells. The objective was to compare the performance of two different acclimation substrates, namely, acetate and cattle manure in single-chamber MECs for methane production. The experiments consist of three groups; in the first group, cattle manure was used both as inoculum and carbon source; in the two other groups, seed from anaerobic digester was used as inoculum, and cattle manure and acetate with different organic loads were used as carbon sources. A voltage (0.7 V) was applied to all the reactors cyclic voltammetry was used to test activity. The maximum current density for reactors acclimated with acetate and then supplemented with cattle manure reached to 0.19 mA/cm² with 102 ml_{CH₄}/L, 53% coulombic efficiency (CE) and 38% COD removal. In the reactors, fed only with manure, the current density reached to 0.16 mA/cm² with 108 ml_{CH₄}/L, 51% CE and 32% COD removal. Hence, we conclude (i) it is possible to start-up an MEC using cattle manure as the only inoculum and carbon source and (ii) change in the type of substrate in the acclimation period has no effect on the reactor performance.

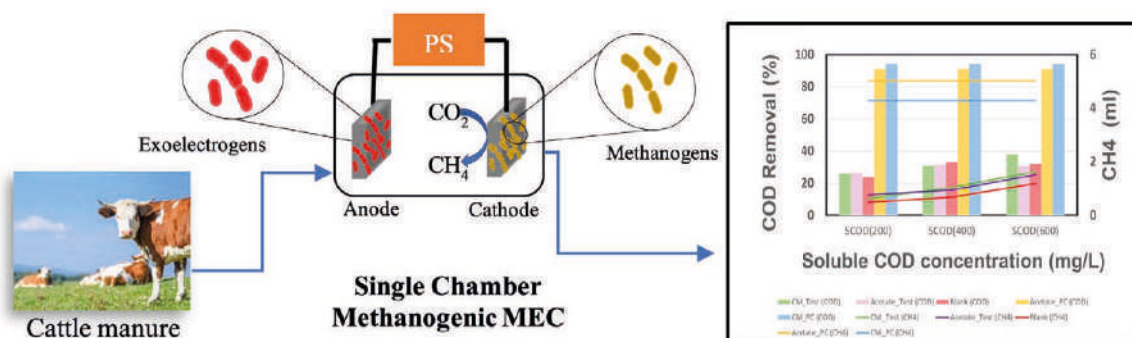

Fig. 1 Schematic representation of a microbial electrolysis cell (MEC) for methane production from cattle manure

Keywords: acclimation, methane, electromethanogenesis, cattle manure, microbial electrolysis cell

Funding: This study was funded by the Office of Sponsored Research at METU grant number 10776.

Strategies for increasing production of bioproducts from CO₂ by Microbial electrosynthesis (MES)

Eileen Yu^{1,2*}, Paniz Izadi², Jean-Marie Fontmorin², Da Li^{1,2}, Ian Head³

1 Department of Chemical Engineering, Loughborough University, LE11 3TU

2 School of Engineering, Newcastle University, United Kingdom, NE1 7RU

3 School of Natural and Environmental Science, Newcastle University, United Kingdom, NE1 7RU

Email: e.yu@lboro.ac.uk*

In this study, we investigated different strategies to increase acetate and longer chain bio-products from MES. At -1.0V Ag/AgCl applied potential [1], and dissolved CO₂ as carbon source through:

1) addition of external electron donors in addition to cathode [2]

2) application of continuous operational mode [3];

3) modification of cathode with PANI polymer [4].

The effect of hydraulic retention time (HRTs) was investigated with 3 and 7 days (Fig 1). For HRT of 3 days, pH was 5.2 and acetate was the dominant product with the highest production rate of 651.8 ± 214.2 ppm day⁻¹, while for HRT of 7 days, pH was lower at 4.5, lower but stable acetate production rate 280 ppm day⁻¹ was obtained, and more diverse longer chain, C4-C6 products were observed. With additional formate and ethanol to the MES reactors, although acetate was still main product, more diverse and longer chain bio-products were achieved. Further enhancement by using PANI modified biocathode. Reactors were operated during 60 days and PANI-GDEs led to an acetate concentration of 6.85 ± 0.9 g L⁻¹ and 0.20 ± 0.05 g L⁻¹ butyrate. It is possible to control MES process and products by applying different parameters.

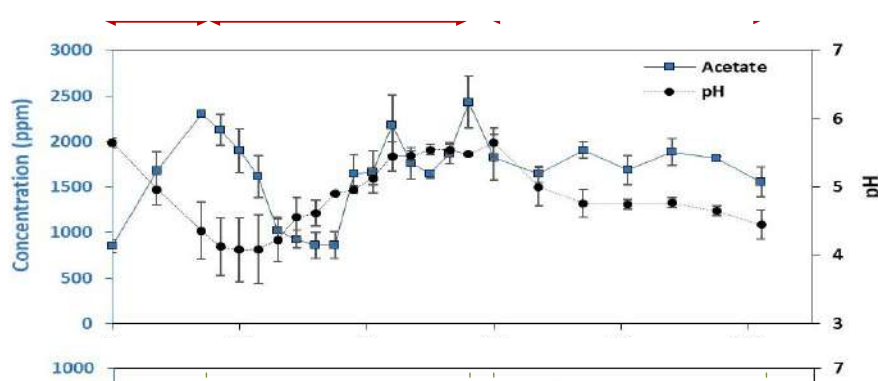

Fig. 1 Acetate production at HRT 3 days and 7 days

Keywords: CO₂ conversion, MES, HRT, additional electron donor, GDE, polymer modification

Funding: EPSRC EP/N009746/1, EP/R021503/1 and EP/V011863/1, NERC MeteoRR (NE/L014246/1) and NBIC

002POC19034

References

- [1] Izadi, P., et al., *npj Biofilms and Microbiomes*, 2020. 6(1): p. 40.
[2] Izadi, P, et al., *Applied Energy*,

2021. 283: p. 116310.

[3] Izadi, P., et al., *Faraday Discussions*, 2021.

[4] Fontmorin, J.-M., et al., *Electrochimica Acta*, 2021. 372: p. 137853.

Bioelectrosynthesis of organic acids from CO₂ using fluidized bed electrodes in a 3 phase reactor.

María Llorente¹, Sara Tejedor-Sanz¹, Abraham Esteve-Núñez¹

¹ University of Alcalá - Department of Chemical Engineering - Ctra Madrid-Barcelona, km 33,6, 28871 Alcalá de Henares, Madrid, Spain

*Email: m.llorente@uah.es

Microbial electrochemical technologies (MET) are becoming more interesting to design and provide solutions to the society pollution issues. One of them is the release of greenhouses gases, as CO₂, in industrial processes. In this study, we investigate a new microbial electrochemical design for the process of Microbial Electrosynthesis (MES). In this context, the CO₂ is microbially reduced using electrons released in the fluid-like electrode of a Microbial Electrochemical Fluidized Bed Reactor (ME-FBR). ME-FBR was operated as a 3 phase reactor (solid-liquid-gas) where working electrode (biocathode) was fluidized by gas, and polarized at different potentials (-0.6, -0.8 and -1 V vs Ag/AgCl). Microorganisms were enriched from real wastewater under anaerobic conditions in presence of 2-bromoethanesulfonic acid (BES) to avoid methanogens growth. Acetate, and other volatile fatty acids, such as formate and propionate, were detected when the reactor was operated. The electrons needed in the reduction of CO₂, were provided by hydrogen produced either electrochemically as well as mediated by microorganisms using the fluid-like biocathode.

Keywords: microbial electrosynthesis, fluidized bed, biocathode, bioelectrochemistry, CO₂ fixation.

Funding: MET-FLUID project (RTI2018-101974-B-C21)

References

- [1] Blasco- Gómez R, et al. Steering bio-electro recycling of carbon dioxide towards target compounds through novel inoculation and feeding strategies. *Journal of Environmental Chemical Engineering*, 2021, 9: 105549
- [2] Nevin K. P, et al. Electrosynthesis of organic compounds from carbon dioxide is catalyzed by a diversity of acetogenic microorganisms. *Applied and Environmental Microbiology*, 2011, 77(9), 2882-2886.
- [3] Nevin K. P, et al. Microbial electrosynthesis: feeding microbes electricity to convert carbon dioxide and water to multicarbon extracellular organic compounds. *MBio*, 2010, 1(2), 1:4.
- [4] Tejedor-Sanz S, et al. *Geobacter* dominates the inner layers of a stratified biofilm on a fluidized anode during brewery wastewater treatment. *Frontiers in Microbiology*, 2018, 9: 378.



Posters

5th EU-ISMET_{ONLINE}
| 5th European Meeting of the International Society
for Microbial Electrochemistry and Technology

13th - 15th September 2021

Index - Posters

Large-scale meta-analysis methodology for facilitating the scale-up of bioelectrochemical systems for wastewater treatment - [Florence de Fouchécour](#)

Dual-cathode configuration and headspace gas recirculation enhanced microbial electrosynthesis from CO₂ using *Sporomusa ovata* - [Suman Bajracharya](#)

To the extreme: the effect of temperature on psychrotolerant *Shewanella loihica* and its electrical output in a microbial fuel cell - [Thessa Van Limbergen](#)

Design, process control, and online measurement for a microbial fuel cell system targeting upscaling in wastewater treatment - [Sarah Brunschweiler](#)

Anaerobic cultivation of genetically engineered *Pseudomonas putida* in a bioelectrochemical system - [André Gemünde](#)

Utilization of phenazines (pyocyanin and phenazine-1-carboxylic acid) by *Enterobacter aerogenes* - [Zubaish Saghir](#)

Persistent biofilms on Dalí: Light sheet microscopy reveals growth of electroactive biofilms in 4D - [Anne Kuchenbuch](#)

“Reversing the Castells principles: The activity stratification in electrified biotrickling filters” - [Benjamin Korth](#)

Bioelectrochemical Methanation of CO₂ from Untreated Steel Mill Gas - [Sabine Spiess](#)

Revealing the potential exoelectrogenic activity of bacteria mediated by their phenazine production - [Angel Franco](#)

Investigation of electrosynthetic acetate production by the novel cathodically active bacterium *Desulfosporosinus orientis* - [Annika Lenic](#)

Real-time monitoring and selective detection of micropollutants using a single chamber microbial fuel cell-based biosensor - [Abdelghani GHANAM](#)

Sustainable Remediation of Crude Oil Contamination by utilizing a Bio-Electrochemical System (BES) - [Altaf Albaho](#)

RedStat: Leveraging open-source projects for laboratory infrastructure - [Carlos Sanchez](#)

CO₂ conversion to formate – insight in electrolyte conditions - [Marc Pfitzer](#)

The role of the quinol dehydrogenase ImcH in *Geobacter sulfurreducens* energy metabolism - [Americo G. Duarte](#)

Voltammetric analysis of the extracellular electron transfer process: Diagnostic criteria for understanding and quantification. - [Jesús Alberto Pérez García](#)

Effect of applied voltage on co-digestion of cattle manure and wastewater biosolids in Anaerobic Digestion-Microbial Electrolysis Cell (AD-MEC) systems - [Yasemin Dilsad Yilmazel](#)

Index - Posters

Converting the offgas of hydrothermal carbonization into methane by means of electromethanogenesis - [Guillermo Pelaz](#)

Co-metabolism of benzene and glucose in microbial fuel cells by synthetic communities - [Natalia Tyszkiewicz](#)

Synthesis of biosurfactants from waste vegetable oil in air-cathode microbial fuel cell - [Aleksander de Rosset](#)

On the use of MEC technology to treat exhausted vine stock wastewater - [Daniela Andrea Carrillo Peña](#)

Prospecting for electrochemically-active hydrocarbon-degrading microorganisms for use in bioelectrochemical remediation of petroleum hydrocarbons. - [Belinda Yayork](#)

Potentiostatic enrichment of electroactive biofilm communities derived from soil contaminated with petroleum products - [Bartosz Widera](#)

Unveiling the role of H₂ in the cathodic electron uptake by acetogenic bacteria - [Laura Muñoz](#)

Stimulating Biofilm Formation of *Sporomusa ovata* for Improved Attachment on Cathode in Microbial Electrosynthesis - [Louise Vinther Grøn](#)

Unveiling the pathways for anoxic ammonium removal in a nitrifying bioelectrochemical system - [Miguel Osset Álvarez](#)

Random genetic mutagenesis in *Geobacter Sulfurreducens* induces high cytochrome activity to achieve high Cr (VI) in bioelectrochemical systems - [MD Tabish Noori](#)

Electrobioremediation of aromatic hydrocarbons using downflow METland® technology - [Eduardo Noriega](#)

SMFC as a tool for the removal of hydrocarbons and metals in the marine environment: a concise research update - [Rosa Anna Nastro](#)

Bacteria Recognition-Extraction from Wastewater (BREW) for next generation microbial electrochemical technologies - [Jack Reeder](#)

Sense Fuet no són tapes: Bioelectrosynthesis scale-up and optimization - a fed-batch story - [Luis Rosa](#)

A Modelling Analysis of pH Change in Microbial Electrosynthesis (MES) Catholytes - [Eileen Yu](#)

Electrochemical behaviour of carbon nanofiber/PDMS composite used as a corrosion-resistant coating for copper in microbial fuel cells - [Bensalah Fatma](#)

Whole bacterial cell surface modified screen printed nitrate biosensor based on direct electron transfer of *Bacillus* sp. electropolymerized within polyaniline films - [Ola Goma](#)

Microbial Electrochemical Snorkel (MES) for Nitrate Reduction - [Joanna Roginska](#)

Comparison of different air cathode designs - [Peter Babiak](#)

Large-scale meta-analysis methodology for facilitating the scale-up of bioelectrochemical systems for wastewater treatment

**Florence de Fouchécour^{1,*}, Valentin Larzillière^{1,2},
Théodore Bouchez¹, Roman Moscoviz²**

¹ Université Paris-Saclay, INRAE, PROSE, 92160, Antony, France

² SUEZ, Centre International de Recherche Sur l'Eau et l'Environnement (CIRSEE), 78230, Le Pecq, France

*Email: florence.de-fouchecour@inrae.fr

Bioelectrochemical systems (BESs) hold great promises for energy-efficient wastewater treatment and they have undergone a quick development since 2003. Notably, over the past few years, the number of BES scale-up reports has increased. To help steering technology development, there is now a clear need for a more thorough joint assessment of the great variety of configurations and operational conditions investigated so far. To that extent, dealing with the inhomogeneity in the way to report results, despite some valuable proposals [1,2], remains a major challenge.

In order to tackle these challenges, a meta-analysis was conducted based on the systematic literature review methodology [3]. This poster details the successive steps of the study: scoping, selection of which data to collect, articles search and selection, database constitution and cleaning, and quantitative analysis. This allowed the exhaustive and reproducible selection of 1,074 articles from which data was extracted. Collected data included both explanatory variables (eg. effluent characteristics, anodic configuration, inoculum ...) and performance indicators (eg. COD removal and coulombic efficiency).

This poster is a methodological complement to the work of Larzillière et al. that will discuss the main conclusions of the meta-analysis.

Keywords: methodology, wastewater treatment efficiency, process scale-up, systematic review

References

- [1] Logan B, et al. Microbial Fuel Cells: Methodology and Technology. *Environmental Science & Technology*, 2006, 5181:5192
- [2] Schröder U, et al. Microbial Electrochemistry and Technology: Terminology and Classification. *Energy & Environmental Science*, 2015, 8, 513
- [3] Xiao Y & Watson M, Guidance on Conducting a Systematic Literature Review. *Journal on Planning Education and Research*, 2019, 39, 1, 93-112

Dual-cathode configuration and headspace gas recirculation enhanced microbial electrosynthesis from CO₂ using *Sporomusa ovata*

Suman Bajracharya, Leonidas Matsakas, Ulrika Rova, Paul Christakopoulos

Biochemical Process Engineering, Division of Chemical Engineering, Department of Civil, Environmental and Natural Resources Engineering, Luleå University of Technology, 971-87 Luleå, Sweden

*Email: suman.bajracharya@ltu.se; bajsuman@gmail.com

High-rate production of acetate and/or other value-added products from the bacterial reduction of CO₂ in microbial electrosynthesis (MES) can be achieved with high reducing power where H₂ appears as a key electron mediator. Due to the low solubility of H₂, the availability of H₂ remains limited to bacteria. H₂ evolution using metal cathode can enhance the availability of H₂ to support high-rate microbial reduction of CO₂. In this study, we investigated the performance of *Sporomusa ovata* for CO₂ reduction when graphite rod and titanium mesh were used combinedly in dual-cathode configuration to promote hydrogen production. At the same time, the headspace gas was recirculated to increase the H₂ availability to the bacteria. High-rate CO₂ reduction was observed at -0.9 V versus Ag/AgCl with double cathode configuration and gas recirculation as compared to the performances of individual cathodes in MES. High titer of acetate (up to ~11 g/L) with a maximum rate of 0.68 g/L/d at -0.9 V vs Ag/AgCl cathode potential was observed, which is higher than the production rate (0.3 g/L/d) obtained under H₂:CO₂:N₂ (60:20:20) gas fermentation with *S. ovata*. High H₂ availability supported the high-rate acetate production from CO₂ with diminished electricity input.

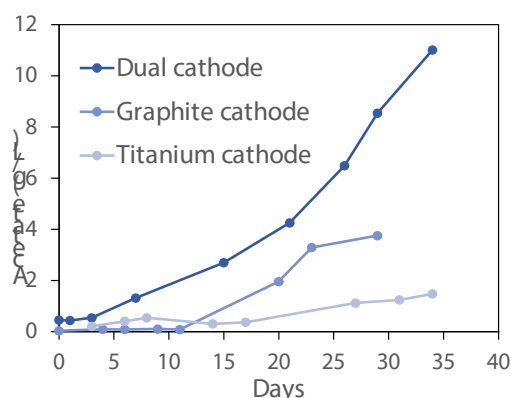

Fig. 1 Graphite rod and Titanium mesh as dual cathode configuration (left). Acetate production in dual cathode and single cathode MESs (right)

Keywords: Microbial Electrosynthesis, CO₂ reduction, Dual-cathode, Hydrogen evolution, gas-liquid mass transfer, gas recirculation

Funding: Swedish Research Council (BEAM no. 2018-03875)

To the extreme: the effect of temperature on psychrotolerant *Shewanella loihica* and its electrical output in a microbial fuel cell

Thessa Van Limbergen^{1*}, Olivier Nouwen², Wim Kuypers², Sofie Thijs³, Jaco Vangronsveld³, Jean V. Manca¹

¹ UHasselt, X-LAB, Agoralaan, 3590 Diepenbeek, Belgium

² UHasselt, Faculty of Medicine and Life Sciences, Agoralaan, 3590 Diepenbeek, Belgium

³ UHasselt, Centre for Environmental Sciences, Agoralaan, 3590 Diepenbeek, Belgium

*Email: thessa.vanlimbergen@uhasselt.be

Temperature is a determining factor in the performance of bioelectrochemical systems[1]. Microbial fuel cells (MFCs), for instance, convert chemical energy into an electrical current with bacteria called exoelectrogens. As most bacteria are mesophilic, more extreme operating temperatures often lead to lower power outputs. Nevertheless, such harsh temperatures can have additional value such as an improved bacterial metabolism and increased conductivity at higher operating temperature[2], or higher coulombic efficiency at lower operating temperature[3]. To broaden the working temperature interval of MFCs, extremophilic exoelectrogens can be used. These bacteria can withstand more extreme environments such as cold (psychrophiles) or hot (thermophiles) environments. Here, the effect of temperature on growth and output of psychrotolerant species *Shewanella loihica* was investigated. *S. loihica* was cultured at 5°C, 15°C and 25°C and growth curves were established with OD₆₀₀ measurements; of each growth phase the morphology was investigated with atomic force microscopy (AFM). MFCs with *S. loihica* operated and monitored for 30 days at identical temperatures. The temperature effect was investigated through morphology of planktonic and biofilm cells (AFM), biofilm formation (confocal laser scanning microscopy), mediator quantity (fluorescence spectroscopy) and electrical output (polarisation/power curve). These results aided in uncovering *S. loihica*'s potential to broaden the MFC temperature range.

Keywords: *S. loihica*, psychrotolerant exoelectrogens, microbial fuel cell, temperature dependence

Funding: BOF Doctoral Fund (Hasselt University)

References

- [1] Behera M, et al. Effect of operating temperature on performance of microbial fuel cell. *Water Science and Technology*, 2011, 64: 917
- [2] Gadkari S, et al. Influence of temperature and other system parameters on microbial fuel cell performance: Numerical and experimental investigation. *Chemical Engineering Journal* 2020, 388: 124176.
- [3] Dopson M, et al. Possibilities for extremophilic microorganisms in microbial electrochemical systems. *FEMS Microbiology Reviews* 2016,40: 164

Design, process control, and online measurement for a microbial fuel cell system targeting upscaling in wastewater treatment

Sarah Brunschweiger*, Vera Kranich, Thomas Hofmann, Karl Glas

Chair of Food Chemistry and Molecular Sensory Science,
Technical University of Munich,

Lise-Meitner-Strasse 34, 85354 Freising, Germany

*Email: sarah.brunschweiger@tum.de

The power density of a microbial fuel cell (MFC) is influenced by its system configuration and the process conditions contributing directly to the efficiency of electroactive biofilms [1]. Commercialization of MFCs for wastewater treatment requires larger scale MFCs to handle greater wastewater flows [2].

The tubular 2-liter single-chamber MFC, adapted for brewery wastewater treatment, was designed considering scalability, process control and instrumentation. The scale-up potential and design limits were calculated taking into account key factors (e.g. electrode packing density) and the clogging tendency of carbon fiber brushes when used as anode electrodes and in combination with VITO CORE® cathodes. The parallel use of the automated MFC system provided the opportunity to compare batch and continuous flow under the same process conditions. Online sensors (mass flow, pH, conductivity) enabled analysis of the wastewater during long-term MFC operation on a laboratory scale, allowing conclusions to be drawn for the necessary wastewater management for the use of MFCs in breweries.

Keywords: microbial fuel cell design, process control, brewery wastewater, scale-up potential

Funding: German Federal Ministry for Economic Affairs and Energy (grant number: IGF 20789 N/1)

References

- [1] Borole A, et al. Electroactive biofilms: current status and future research needs. *Energy Environ. Sci.*, 2011, 4: 4813–4834
- [2] Logan B, et al. Assessment of microbial fuel cell configurations and power densities. *Environ. Sci. Technol. Lett.* 2015, 2: 206–214

Anaerobic cultivation of genetically engineered *Pseudomonas putida* in a bioelectrochemical system

André Gemünde^{1,2,*}, Hendrik Schewe², Roland Ulber³, Dirk Holtmann^{1,2}

¹ TH Mittelhessen University of Applied Sciences, Institute of Bioprocess Engineering and Pharmaceutical Technology,

Wiesenstraße 14, 35390 Giessen, Germany

² DECHEMA Research Institute, Theodor-Heuss-Allee 25, 60486 Frankfurt am Main, Germany

³ Technical University Kaiserslautern, Bioprocess Engineering, Gottlieb Daimler-Strasse 49, 67663 Kaiserslautern, Germany

*Email: andre.gemuende@lse.thm.de

In order to establish bio-based processes, the optimization of material- and energy-efficiency is one of the key performance indicators. Therefore, a focus is the establishment of anaerobic processes. These processes could offer many advantages over aerobic processes, such as bypassing oxygen limitations, higher carbon yields and less foaming [1].

Here, a *Pseudomonas putida* F1 strain is used for anaerobic cultivation in a bioelectrochemical system (BES). The anode respiration via a mediator was already described [2]. Here we investigated the heterologous expression of electron transfer proteins from *Shewanella oneidensis* in *P. putida* to intensify the productivity of 2-ketogluconate (2-kga). For the expression of CymA and MtrA from *S. oneidensis*, two vectors were synthesized and transformed into *P. putida*. CymA could be identified via expression analysis and numerous other heme-containing proteins were detected in wildtype and genetically modified organism (GMO). In the BES, no benefit was found for the GMO in terms of the productivity of 2-kga. It is shown, however, that the wildtype can carry out an “overflow” metabolism in the BES, which delivers an increased current and is possibly limited by the available amount of oxidized mediator. The fermentation supernatants also showed the accumulation of acetoin as a novel byproduct.

Keywords: Anoxic metabolism, redox mediators, mediated extracellular electron transfer, *Pseudomonas putida* F1
Funding: Federal Ministry of Education and Research – BMBF (031B0523)

References

- [1] Weusthuis et al. Microbial production of bulk chemicals: development of anaerobic processes. Trends in Biotechnology, 2011, 29:153–158
- [2] Lai et al. Anoxic metabolism and biochemical production in *Pseudomonas putida* F1 driven by a bioelectrochemical system. Biotechnology for Biofuels, 2016, 9:39

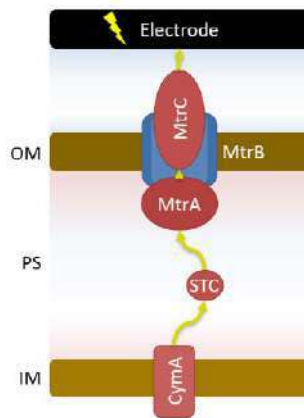

Fig. 1 Electron transfer proteins from *S. oneidensis*.

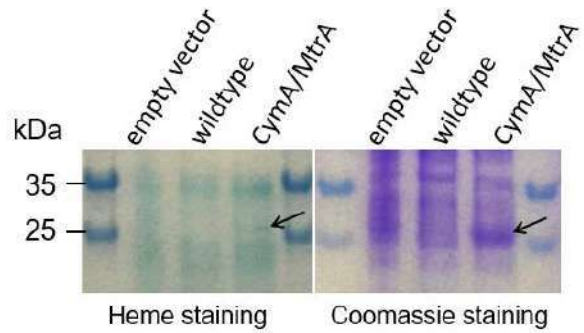

Fig. 2 Expression of CymA and other heme-containing proteins.

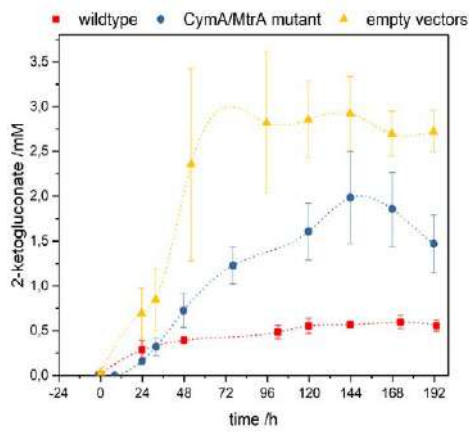

Fig. 3 Productivity of 2-ketogluconate with CymA/MtrA mutant, empty vector control and wildtype.

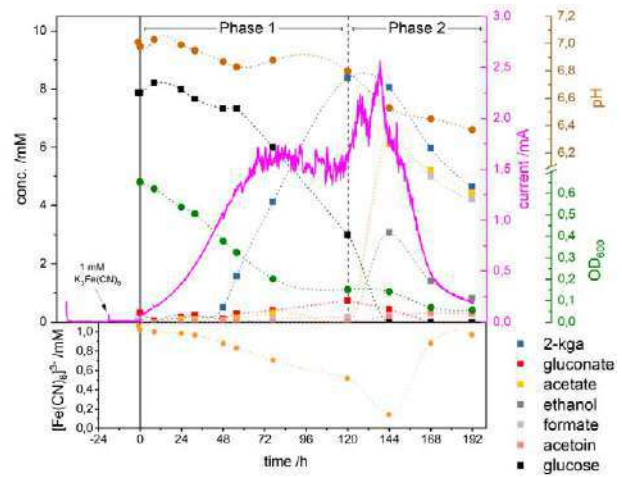

Fig. 4 Metabolic shift in BES cultivation together with depletion of oxidised mediator.

Utilization of phenazines (pyocyanin and phenazine-1-carboxylic acid) by *Enterobacter aerogenes*

Zubaish Saghir^{1, 2}, Miriam A. Rosenbaum^{1, 2*}

¹ Leibniz Institute for Natural Product Research and Infection Biology, Hans-Knöll-Institute, Adolf-Reichwein-Str. 23, 07745 Jena, Germany

² Faculty of Biological Science, Friedrich-Schiller-University Jena, Germany

*Email: miriam.rosenbaum@leibniz-hki.de

Aerobic respiration is considered the most energy efficient form of metabolism. However, oxygen is toxic to several industrially relevant biochemical products, e.g. redox enzymes, and therefore, cannot be utilized for their production (1). Inside an anaerobic bioelectrochemical system (BES), *Enterobacter aerogenes* (a facultative aerobe) is capable of utilizing an anode as terminal electron acceptor by using phenazine redox mediators; electrochemically active, secondary metabolites produced by *Pseudomonas aeruginosa* (2, 3). By doing so, it induces a partial shift in its metabolism from fermentation to energetically beneficial, electrode-based respiration resulting in higher biomass yield (3).

In this study, the process of electro-respiration in *E. aerogenes* as an alternate approach to aerobic respiration was investigated in more detail. Multiple concentrations of phenazines (pyocyanin/PYO and phenazine-1-carboxylic acid/PCA) in BESs were tested under anoxic conditions.

An increase in the biomass production was observed with increasing concentration of phenazines. However, the expected simultaneous decrease in fermentation by-products was not seen. PCA was found to be energetically less beneficial than PYO due to its more negative electrochemical potential.

Keywords: Bioelectrochemical system, Phenazines, Electro-respiration

Funding: This research is funded by the European Research Council (ERC) consolidator grant #864669.

References

1. Jäger CM, Croft AK: Anaerobic radical enzymes for biotechnology. *ChemBioEng Reviews*, 2018, 5(3):143-162.
2. Schmitz, S., & Rosenbaum, M. A. Boosting mediated electron transfer in bioelectrochemical systems with tailored defined microbial co-cultures, *Biotechnology and Bioengineering*, 2018, 115(9): 2183-2193
3. Venkataraman A., et al. Metabolite-based mutualism between *Pseudomonas aeruginosa* PA14 and *Enterobacter aerogenes* enhances current generation in bioelectrochemical systems. *Energy Environmental Science*, 2011, 4(11): 4550-4559.

Pintant biofilms com Dalí: Light sheet microscopy reveals growth of electroactive biofilms in 4D

Anne Kuchenbuch¹, Christin Koch¹, Maria Marosvölgyi², Klaus Weisshart³, Falk Harnisch^{1*}

¹Department of Environmental Microbiology, UFZ – Helmholtz-Centre for Environmental Research, Leipzig, Germany

²arivis AG, arivis Vision, München, Germany

³Carl Zeiss Microscopy GmbH, Jena, Germany

*Email: falk.harnisch@ufz.de

Light sheet fluorescence microscopy (LSFM) enables 4-dimensional imaging of eukaryotic cells and tissues [1,2]. This imaging technology allows large specimen to be investigated in vivo under physiological conditions in a non-destructive way. We show that the advantages of LSFM are also highly valuable for prokaryotic analyses by studying label-free natural microbial biofilm development on the example of an anaerobic electroactive biofilm [3]. Therefore a bioelectrochemical system was implemented in the LSFM. The biofilm was grown on a graphite electrode and the current production as a measure of activity was monitored over time. This is the first time that by label-free and non-destructive imaging the growth could be linked to the production of current in vivo by monitoring an anaerobically grown electroactive bacterial biofilm with high spatial and temporal resolution. After exponential growth a homogeneous biofilm (thickness of 9 µm) was formed. This was followed by a stratification of the biofilm including formation of 3D structures (see Figure 1). Light reflection was sufficient to visualize the biofilm structure and development over time. The morphology was confirmed using fluorescent staining and thus LSFM can paint biofilms as (sur)realistic as Dalí.

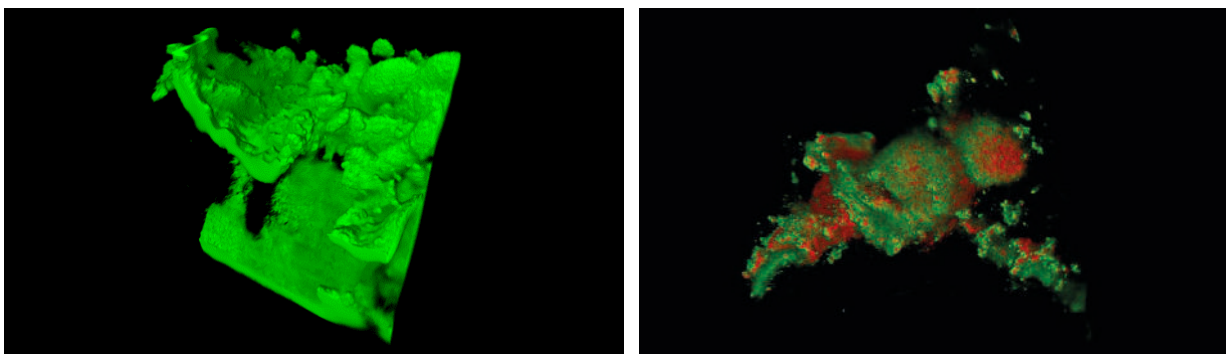

Fig. 1: Painting biofilms as Dalí: A) Light reflection (excitation with 405 nm) is sufficient to visualize the 3-dimensional biofilm surface structure. B) LIVE/DEAD nucleic acid fluorescent staining confirms the organization of the individual cells and the three-dimensional organization of the biofilm.

Keywords: microscopy, biofilms, electrophysiology

Funding: This work was supported by the Helmholtz-Association in the frame of the Integration Platform “Tapping na-

ture’s potential for sustainable production and a healthy environment” at the UFZ.

References

[1] Huisken J, Swoger J, Del Bene F, Wittbrodt

J, Stelzer EHK. Optical sectioning deep inside live embryos by selective plane illumination microscopy. *Science* 2004, 305 (5686) 1007-1009.

[2] Reynaud EG, Peychl J, Huisken J, Tomancak P. Guide to light-sheet microscopy for adventurous

biologists. *Nat Methods* 2014, 12 30–34.

[3] Koch, C. Kuchenbuch A, Marosvölgyi M, Weisshart K, Harnisch F. Label-free four-dimensional visualization of anaerobically growing electroactive biofilms, *Cytom. Part A* 2020, 97 737 - 741.

Reversing the Castells principles: The activity stratification in electrified biotrickling filters

**Benjamin Korth^{1*}, Richard Hönig¹, Narcís Pous², Sebastià Puig²,
Falk Harnisch^{1*}**

¹ Department of Environmental Microbiology, Helmholtz Centre for Environmental Research – UFZ,

Permoser Str. 15, 04318 Leipzig, Germany

² Laboratory of Chemical and Environmental Engineering (LEQUiA), Institute of the Environment, University of Girona,

Carrer Maria Aurèlia Capmany, 69, E-17003, Girona, Spain

*Email: benjamin.korth@ufz.de, falk.harnisch@ufz.de

Recently, electrified biotrickling filters were introduced as sustainable microbial electrochemical technology (MET) for treating nitrogen-contaminated waters while neither requiring addition of chemicals nor external aeration¹. The simultaneous degradation of ammonium and nitrate to dinitrogen was achieved by establishing a redox potential stratification in the filter constituted of glass beads (non-polarized aerobic zone) and graphite granules as conductive filling material (polarized anoxic oxidative/reductive zones). It was also demonstrated that this MET can be applied in aquaponics as it provides an appropriate effluent quality.

For revealing the stratification of activity within electrified biotrickling filters, the electrified biotrickling filters were modified by tailor-made sampling systems allowing a minimal-invasive sampling of graphite from the filling. Subsequently, the granules were electrochemically analyzed with the recently developed e-Clamp² for providing thermodynamic information about the redox centers responsible for the extracellular electron transfer and participating in the bioelectrochemical degradation of ammonium and nitrate. Thereby, several redox signals in the range of -500 to +100 mV (vs. Ag/AgCl sat. KCl) were observed that were distinctively different than previous reported redox signals of similar processes^{3,4} the elucidation of the underlying extracellular electron transfer (EET). A genetic analysis (T-RFLP and metagenomics) revealed a microbial stratification being putatively linked to the stratification of activity within the individual zones.

Keywords: bioelectrochemical nitrogen removal, cyclic voltammetry, redox potential stratification, circular bioeconomy, biocathode

Funding: This research was carried out in the project "Wireless Aquaponic Farming in Remote Areas: A smart adaptive socio-economic solution" (WAFRA) funded within the 7th Framework Program (ERANETMED).

References

- (1) Pous, N.; Korth, B.; Osset-Álvarez, M.; Balaguer, M. D.; Harnisch, F.; Puig, S. Electrifying Biotrickling Filters for the Treatment of Aquaponics Wastewater. *Bioresour. Technol.* **2021**, *319* (3), 124221. <https://doi.org/10.1016/j.biortech.2020.124221>.
- (2) Quejigo, J. R.; Rosa, L. F. M.; Harnisch, F. Electrochemical Characterization of Bed Electrodes Using Voltammetry

- of Single Granules. *Electrochem. Commun.* **2018**, *90*, 78–82. <https://doi.org/10.1016/j.elecom.2018.04.009>.
- (3) Pous, N.; Koch, C.; Colprim, J.; Puig, S.; Harnisch, F. Extracellular Electron Transfer of Biocathodes: Revealing the Potentials for Nitrate and Nitrite Reduction of Denitrifying Microbiomes Dominated by *Thiobacillus* Sp. *Electrochem. Commun.* **2014**, *49*, 93–97. <https://doi.org/10.1016/j.elecom.2014.10.011>.
 - (4) Vilajeliu-Pons, A.; Koch, C.; Balaguer, M. D.; Colprim, J.; Harnisch, F.; Puig, S. Microbial Electricity Driven Anoxic Ammonium Removal. *Water Res.* **2018**, *130*, 168–175. <https://doi.org/10.1016/j.watres.2017.11.059>.

Bioelectrochemical Methanation of CO₂ from Untreated Steel Mill Gas

Sabine Spiess^{1,*}, Amaia Sasiain¹, Niels Waldmann², Eva Neuhauser², Andreas Paul Loibner³, Nina Kieberger⁴, Marianne Haberbauer¹

¹ K1-MET GmbH, Stahlstrasse 14, 4020 Linz, Austria

² acib GmbH, Konrad-Lorenz-Strasse 20, 3430 Tulln an der Donau, Austria

³ University of Natural Resources and Life Sciences Vienna, Dept. of Agrobiotechnology, IFA-Tulln, Inst. of Environmental Biotechnology, Konrad-Lorenz-Strasse 20, 3430 Tulln an der Donau, Austria

⁴ voestalpine Stahl GmbH, voestalpine-Strasse 3, 4020 Linz, Austria

*E-Mail: sabine.spiess@k1-met.com

Steel production is one of the most energy-intensive processes in which 7% of global CO₂ is emitted. Therefore, the project LOCON (low energy CO₂ conversion and utilization at the example of steel industry) focuses on the biological methanation of CO₂ from untreated steel mill gases by usage of a bioelectrochemical system (BES) and geomethanation. In a BES, at least one electrode is covered by an electroactive biofilm, which catalyses oxidation or reduction processes. In LOCON we want to take a closer look on a BES with a bioanode and a biocathode. At the bioanode microbial oxidation of organics (e.g., wastewater) occurs, whereby electrons are produced which are supplied to a CO₂ reducing biocathode (Fig. 1). To test the biological methanation of CO₂ from untreated steel mill gas, a lab-scale BES was set up. During long-term operation different process parameters like chemical oxygen demand removal, current generation and CH₄ production were monitored. In the first stage the biocathode was flushed with pure CO₂. After optimization of process parameters and successful methanation, the CO₂ conversion of untreated steel mill gas was tested, and the biofilm community composition was analysed.

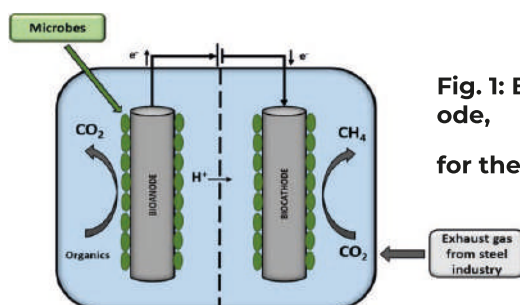

Fig. 1: BES, consisting of a bioanode and a biocathode, for the conversion of CO₂ rich exhaust gas to CH₄

Keywords: bioelectrochemical system, bioanode, biocathode, CH₄ production, CO₂ conversion

Funding: This project has received funding from the Austrian Research Promotion Agency (FFG).

References

[1] Villano M., et al. Electrochemically assisted methane production in a biofilm reactor. *Journal of Power Sources* 2011; 196: 9467–9472

[2] Cheng S., et al. Direct biological conversion of electrical current into methane by electromethanogenesis. *Environmental Science and Technology* 2009; 43: 3953–3958

Revealing the potential exoelectrogenic activity of bacteria mediated by their phenazine production

Angel Franco¹, Miriam Agler-Rosenbaum^{1,2*}

¹ Bio Pilot Plant, Leibniz-Institut für Naturstoff-Forschung und Infektionsbiologie

- Hans-Knöll-Institut - Adolf-Reichwein-Straße 23, 07745 Jena

² Faculty of Biological Sciences, Friedrich-Schiller-University, Jena, Germany

*Email: Miriam.Rosenbaum@leibniz-hki.de

The synthesis of redox-active molecules acting as extracellular electron shuttles, such as phenazines, has been predicted based on the presence of genes involved in their biosynthesis (*phzA-G*)¹ or detection (*soxR*)². Phenazine synthesis has been confirmed in a limited number of genera and only few species are employed in bioelectrochemical systems (BES), mainly pseudomonads, native phenazine producers^{3,4}. Here, the potential exoelectrogenic activity mediated by phenazines and their performance within BES was evaluated in diverse species under varying conditions such as medium, oxygen availability, addition of synthetic phenazines, etc. This is the first report indicating that species of genera *Pseudomonas*, *Streptomyces*, *Nocardiosis*, *Brevibacterium*, and *Burkholderia* are electroactive bacteria employing phenazines. Electron discharge to the anode and therefore, the produced electric current correlated with phenazine synthesis, phenazine-1-carboxylic acid being the dominant redox mediator in BES reaching concentrations of 76 mg/L and anodic current of 14 $\mu\text{A}/\text{cm}^2$. Phenazine-1-carboxamide and pyocyanine were produced in lower concentrations but also contributed to current generation. Phenazine addition to the BES decreased the biomass production and increased current in selected cases. Elucidating the phenazine usage by bacteria will improve biotechnological applications of oxygen limited BES with single or mixed cultures, allowing for the discovery and synthesis of new bioproducts.

Keywords: exoelectrogenic bacteria, phenazine, bioelectrochemical system, electric current.

Funding: This research is funded by the European Research Council (ERC) consolidator grant # 864669.

References

- [1] Schneemann I, et al. Genetic approach for the fast discovery of phenazine producing bacteria. *Marine Drugs*, 2011, 9: 772-789
- [2] Glasser N, et al. The colorful world of extracellular electron shuttles. *Annual Review of Microbiology*, 2017, 71: 731-751
- [3] Bosire E, Rosenbaum M. Electrochemical potential influences phenazine production, electron transfer and consequently electric current generation by *Pseudomonas aeruginosa*. *Frontiers in Microbiology*, 2017, 8: 892
- [4] Schmitz, et al. Engineering mediator-based electroactivity in the obligate aerobic bacterium *Pseudomonas putida* KT2440. *Frontiers in Microbiology*, 2015, 6: 284

Investigation of electrosynthetic acetate production by the novel cathodically active bacterium *Desulfosporosinus orientis*

Annika Lenic^{1,2}, Valeria Agostino³, Miriam A. Rosenbaum^{1,2,*}

¹ Bio Pilot Plant, Leibniz Institute for Natural Product Research and Infection Biology – Hans-Knöll-Institute, Beutenbergstr. 11a, 07745 Jena, Germany

² Faculty of Biological Sciences, Friedrich-Schiller-University, Fürstengraben 1, 07743 Jena, Germany

³ Centre for Sustainable Future Technologies – Fondazione Istituto Italiano di Tecnologia, Via Livorno, 60, 10144 Torino, Italy

*Email: miriam.rosenbaum@leibniz-hki.de

During recent years, Microbial Electrosynthesis directed attention towards the exploitation of CO₂-rich waste gas streams for electrosynthesis of value-added products. We investigated the acetate bioelectrosynthesis of the cathodically active, sulfate reducing bacterium *Desulfosporosinus orientis*. Acetogenesis was observed during electroautotrophic growth, previously ^[1]. However, since sulfate respiration is energetically more favorable ^[2], CO₂ fixation was low. Therefore, Adaptive Laboratory Evolution towards reduced sulfate utilization (25 % and 50 % of the optimal concentration) was performed. New strains were analyzed during autotrophic growth in serum bottles and in bioelectrochemical H-type reactors. Additionally, acetate bioelectrosynthesis was confirmed through stable isotope labeling experiments. The highest electrosynthetic acetate titer was 1.91 mM (50 % sulfate-strain). The 25 % sulfate-strain performed less well in terms of titers, but had higher yields of acetate per biomass. These results showed that enhanced acetate production by restricting sulfate respiration in *D. orientis*, come at the expense of reduced biomass formation. During autotrophic growth in serum bottles, enhanced acetogenic titers and formation of a new by-product, butyric acid, were observed ^[3]. This highlights that the potential of the strain was not fully tapped in the electrochemical reactors, yet and deeper exploration of electroautotrophic CO₂ fixation harbors further expandable possibilities.

Keywords: Microbial Electrosynthesis, Acetogenesis, Adaptive Laboratory Evolution keyword

Funding: ERC Consolidator Grant 2019, Project: e-MICROBe

References

- [1] de Campos Rodrigues, T., & Rosenbaum, M. A. (2014). Microbial Electroreduction: Screening for New Cathodic Biocatalysts. *ChemElectroChem*, 1(11), 1916–1922. <https://doi.org/10.1002/celec.201402239>
- [2] Conrad, R., Schink, B., & Phelps, T. J. (1986). Thermodynamics of H₂-Consuming and H₂-Producing Metabolic Reactions in Diverse Methanogenic Environments under in situ Conditions. *FEMS Microbiology Letters*, 38(6), 353–360. [https://doi.org/10.1016/0378-1097\(86\)90013-3](https://doi.org/10.1016/0378-1097(86)90013-3)
- [3] Agostino V, Lenic A, Bardl B, Rizzotto V, Phan ANT, Blank LM and Rosenbaum MA (2020) Electrophysiology of the Facultative Autotrophic Bacterium *Desulfosporosinus orientis*. *Frontiers in Bioengineering and Biotechnology*, 8:457. <https://doi.org/10.3389/fbioe.2020.00457>

Real-time monitoring and selective detection of micropollutants using a single chamber microbial fuel cell-based biosensor

Abdelghani GHANAM^{1,2,*}, Naoufel HADDOUR², Hasna MOHAMMADI¹, Aziz AMINE¹, François BURET²

¹ Université Hassan II de Casablanca, Faculté des Sciences et Techniques de Mohammedia (FSTM), Equipe Analyses Chimiques et Biocapteurs, Laboratoire Génie des Procédés et Environnement, 20800 Mohammedia, Maroc

² Univ Lyon, Ecole Centrale de Lyon, INSA Lyon, Université Claude Bernard Lyon 1, CNRS, Ampère, UMR5005, 69130 Ecully, France

*Email: abdelghani.ghanam@ec-lyon.fr; abdo.ghanam2@gmail.com

On-line monitoring of water quality plays a central role in providing safe drinking water and in the operation of wastewater treatment plants. Biosensors based on microbial fuel cell (MFC) platform have recently been receiving increasing attention [1]. MFCs are bioelectrochemical devices that utilize microorganisms as catalysts to convert chemical energy to electrical energy [2]. Biofilms composed of electrochemically active bacteria (EAB), oxidize organic matter in the anodic compartment to produce protons and electrons. The resulting electrons are captured at the anode and transferred to the cathode through an external circuit producing electricity. MFC-based biosensors rely on a change in the output current for any disturbances on the metabolism of the EAB's activity. They offer the advantages of being self-powered and directly generate electrical signals without any need for a separated transducer. However, it is challenging to use MFC biosensors for toxicity monitoring when a high specificity is required. In this study, a new configuration of single-chamber cube biosensors based on MFC was investigated to further improve the MFC sensor's specificity. A differential analysis approach (DAA) based on the difference in responses of MFC biosensors based on micropollutant-adapted and nonadapted biofilms was investigated to detect specifically the target analyte.

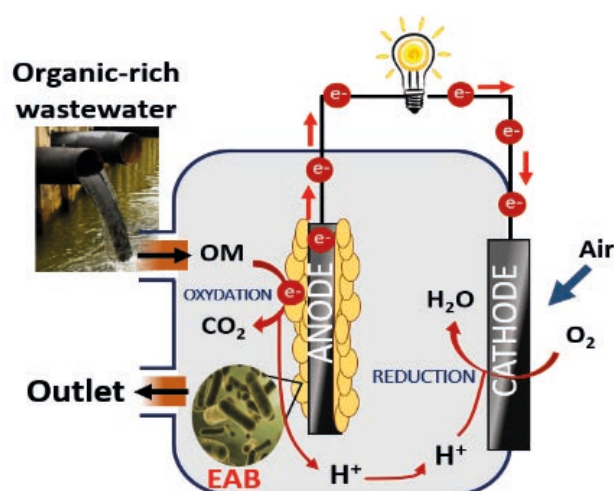

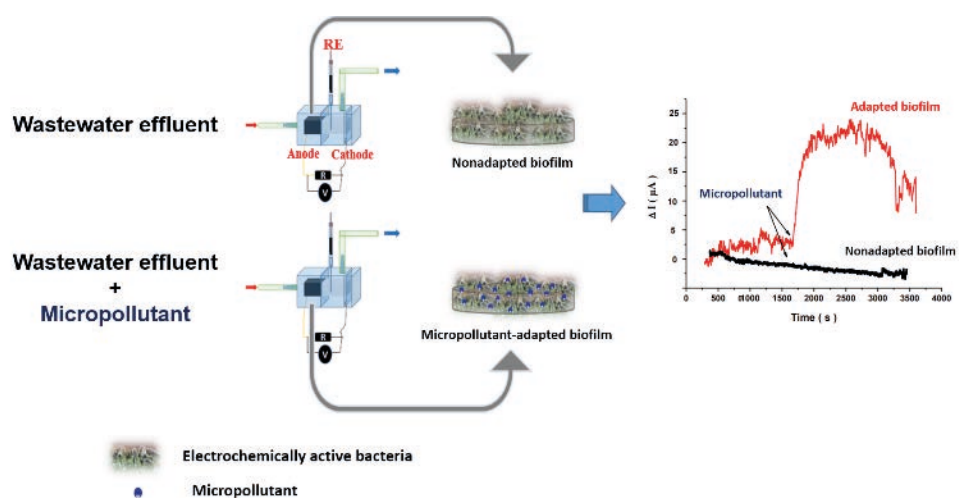

Fig. 1.

A) Schematic of a MFC-based biosensors,

B) illustration of micropollutant-adapted and nonadapted biofilm and change in the output current

Keywords: Adapted-biofilms, biosensor, microbial fuel cell, micropollutant, real-time detection, differential analysis approach

Funding: The authors greatly acknowledge the PHC Maghreb 2019 project **N°41382WC** for its support to do this work.

References

- [1] Li M, et al. Performance of Pb (II) reduction on different cathodes of microbial electrolysis cell driven by Cr (VI)-reduced microbial fuel cell. *Journal of power sources*, 2019, 418, pp. 1–10.
- [2] Paitier A, et al. Microbial fuel cell anodic microbial population dynamics during MFC start-up. *Biosensors and bioelectronics*, 2017, 92, pp. 357–363.

Sustainable Remediation of Crude Oil Contamination by utilizing a Bio-Electrochemical System (BES)

Altaf AlBaho¹, Rory Doherty², Deepak Kumaresan³,
Caroline Gauchotte-Lindsay⁴

¹ Queen's University of Belfast, SNBE, Belfast, UK, BT9 5AG

² Queen's University of Belfast, SNBE, Belfast, UK, BT9 5AG

³ Queen's University of Belfast, SBS, Belfast, UK, BT9 5DL

⁴ University of Glasgow, SE, Glasgow, UK, G12 8QQ

*Email: aaibaho01@qub.ac.uk

Sustainable remediation has become a fundamental approach in the development of remediation technologies. Bio-Electrochemical Systems (BES) are an innovative method which is considered as a prime candidate for the bioremediation of contaminated soil that are also good candidates as sustainable remediation technologies. Crude oil contaminated land is a challenge for BES due to the toxicity and recalcitrant characteristics of crude oil. Parameters such as BES configuration and electrode materials must be considered for BES platform to be adopted as a sustainable remediation approach. The effect of ionic strength applied to a BES to test resolution of BES electrical output and effect of changes in operating procedure (concentration, temperature). The electrochemical difference between anode and cathode produces an electrical signal that is a linear relationship with concentration. This work considers a BES chamber that focuses on the degradation of Kuwaiti soil contaminated with crude oil. Initial data indicates that there is a slow change in the voltage and power output suggesting it might take longer time for the biodegradation and enrichment of the electrogenic microbial communities. The controlled lab-scale BES have been identified to assist civil engineers for designing and scaling up BESs for the enhancement of semi-passive medium term remediation systems.



Fig. 1 (BES configuration)

Keywords: Bio-electrochemical system (BES), Crude oil contaminated soil, Sustainable remediation, Microbial ecology, Biodegradation.

Funding: Queen's University of Belfast

References

- [1] Cecconet D, Sabba F, Devecseri M, Callegari A, Capodaglio AG. 2020. In situ groundwater remediation with bioelectrochemical systems: a critical review and future perspectives. *Environment International* 137: 105550.
- [2] CL:AIRE. 2020. Supplementary report 2 of the SuRF-UK framework: selection of indicators/criteria for use in sustainability assessment for achieving sustainable remediation. *Contaminated Land: Applications in Real Environments (CL:AIRE)*, Haddenham. ISBN: 9781905046348.
- [3] Curtis TP, Head IM, Graham DW. 2003. Theoretical ecology for engineering biology. *Environmental Science & Technology* 37: 64A-70A.
- [4] Daghighi M, Aulenta F, Vaiopoulou E, Franzetti A, Arends JBA, et al. 2017. Electrobioremediation of oil spills. *Water Research* 114: 351-370.
- [5] Doherty R, McPolin B, Kulesa B, Frau A, Kulakova A, et al. 2015. Microbial ecology and geoelectric responses across a groundwater plume. *Interpretation* 3: SAB9-SAB21.
- [6] Huang DY, Zhou SG, Chen Q, Zhao B, Yuan Y, et al. 2011. Enhanced anaerobic degradation of organic pollutants in a soil microbial fuel cell. *Chemical Engineering Journal* 172: 647-653.
- [7] Kirmizakis P, Doherty R, Mendonça CA, Costeira R, Allen CCR, et al. 2019. Enhancement of gasworks groundwater remediation by coupling a bio-electrochemical and activated carbon system. *Environmental Science and Pollution Research* 26: 9981-9991.
- [8] Knight P, Jenkins JO. 2009. Adopting and applying eco-design techniques: a practitioners perspective. *Journal of Cleaner Production* 17: 549-558.
- [9] Logan BE, Hamelers B, Rozendal R, Schröder U, Keller J, et al. 2006. Microbial fuel cells: methodology and technology. *Environmental Science & Technology*.
- [10] Lu L, Yazdi H, Jin S, Zuo Y, Fallgren PH, et al. 2014. Enhanced bioremediation of hydrocarbon-contaminated soil using pilot-scale bioelectrochemical systems. *Journal of Hazardous Materials* 274: 8-15.
- [11] Meckenstock RU, Elsner M, Griebl C, Lueders T, Stumpp C, et al. 2015. Biodegradation: updating the concepts of control for microbial cleanup in contaminated aquifers. *Environmental Science & Technology* 49: 7073-7081.
- [12] Nathanail CP, Bakker LMM, Bardos P, Furukawa Y, Nardella A, et al. 2017. Towards an international standard: the ISO/DIS 18504 standard on sustainable remediation. *Remediation* 28: 9-15.
- [13] Nelson-Smith A. 1972. Oil pollution and marine ecology. *Springer*, US. ISBN:9780306307232.
- [14] Qin G, Gong D, Fan MY. 2013. Bioremediation of petroleum-contaminated soil by biostimulation amended with biochar. *International Biodeterioration and Biodegradation* 85: 150-155.
- [15] Weelink SAB, van Eekert MHA, Stams AJM. 2010. Degradation of BTEX by anaerobic bacteria: physiology and application. *Reviews in Environmental Science and Biotechnology* 9:359-385.

RedStat: Leveraging open-source projects for laboratory infrastructure

Carlos Sánchez¹, Piet N.L. Lens¹

¹ National University of Ireland Galway, University Road,
H91 TK33 Galway, Ireland

*Email: c.sanchez2@nuigalway.ie

carlossanchezfernandez01@gmail.com

Laboratory infrastructure often require computers for interfacing and managing data. Moreover, it is often required to have several machines working synchronously. It is possible to use proprietary platforms to sync infrastructure which might involve limitations on the machines utilized or sync data afterwards which can be error prone.

We propose a different scenario by using a local area network and low-cost computers. Due to the memory limitation challenges of using low-cost computer, we present a flexible and easy-to-deploy wi-fi server-client platform. It allows using low-cost Raspberry Pi computers to interface hardware in the laboratory and use up-to-date software tools such as time-series databases and online data visualization tools. This facilitates long-term monitoring and data management. RedStat consists of an installation script that helps configuring the LAN hostname and installs the open software tools required to interface and manage the data monitoring. Node-red acts as the orchestrator of the software integration and RedStat supplies three different example programs to interface 3 open hardware projects: the microcontroller Arduino, the hardware incubator “OpenTCC”¹ heating MET using water jacket recirculation can raise safety issues, whereas heating coils may affect the results of electrochemical analyses.

The proposed open-source temperature-control chamber (OpenTCC and the open-source potentiostat “dStat”²) giving limited information about their circuitry and behaviour which can make development of new measurement techniques and integration with other instruments challenging. Recently, a number of lab-built potentiostats have emerged with various design goals including low manufacturing cost and field-portability, but notably lacking is an accessible potentiostat designed for general lab use, focusing on measurement quality combined with ease of use and versatility. To fill this gap, we introduce DStat (<http://microfluidics.utoronto.ca/dstat>).

RedStat provides an infrastructure to develop similar programs interacting different type of serial communication devices.

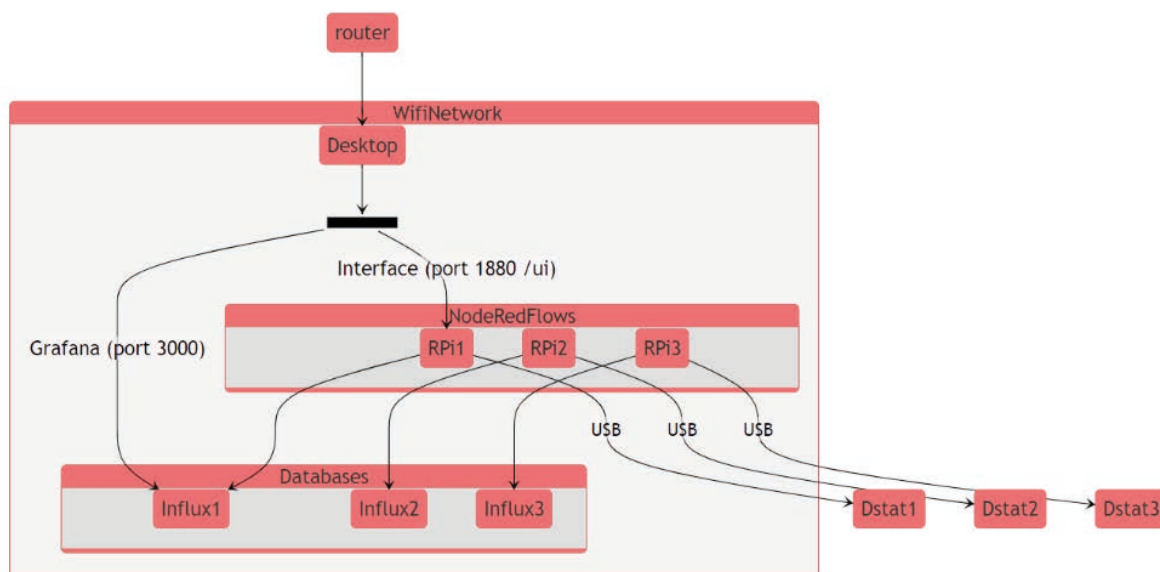

Fig. 1 Schematic of the RedStat platform showing the wi-fi LAN with several Raspberry Pis, the time-series database InfluxDB and the serial communication devices dStat.

Keywords: Raspberry Pi, time-series, databases, potentiostat, wi-fi.

Funding: Science Foundation Ireland (SFI) Professorship Programme *Innovative Energy Technologies for Biofuels, Bioenergy and a Sustainable Irish Bioeconomy* (IETS BIO3; grant number 15/RP/2763)

References

- [1] Sánchez, C. *et al.* OpenTCC: An open source low-cost temperature-control chamber. *HardwareX* **7**, e00099–e00099 (2020).
- [2] Dryden, M. D. M. M. & Wheeler, A. R. DStat: A versatile, open-source potentiostat for electroanalysis and integration. *PLoS ONE* **10**, 1–17 (2015).

CO₂ conversion to formate – insight in electrolyte conditions

Marc Pfitzer¹, Nicolai Bauske¹, Dirk Holtmann^{1*}

¹ Technische Hochschule Mittelhessen Gießen, Institut für Bioverfahrenstechnik und Pharmazeutische Technologie, Wiesenstrasse 14, 35390 Gießen

*Email: dirk.holtmann@lse.thm.de

The sustainable production of value-added chemicals remains one of the major goals of the fossil resources based chemical industry. Reduced C1-compounds, such as CO and formate are promising molecules towards a chemical industry decoupled from fossil feedstock. Moreover, the highly selective electrochemical CO₂ reduction using electricity from renewables creates synergies between energy and chemical production sectors. CO and formate are versatile precursors to more complex carbon compounds. Compared to CO, formate provides several advantages for carbon and energy storage, such as high stability, low safety requirements, good storage characteristics as salt, and its application as a sole substrate for the synthesis of bio-based products. For instance, methanogens can produce methane and high-value products such as isoprenoids, coenzymes, amino acids, and carboxylic acids from CO₂. However, especially when thermophilic methanogens are desirable to use, a preceding CO₂ conversion to formate could circumvent low-solubility issues of H₂ and CO₂ in high-temperature aqueous solutions. Here, we present insights into the electrolyte composition in order to realize drop-in reaction systems. Formate was produced in different electrolytes and a methanogen medium, which provide physiological conditions (salinity and pH) with Faradaic efficiencies as high as 60 %.

Keywords: CO₂ conversion, formate, bioelectrochemistry, methanogens

Funding: This work was supported by the BMBF (No. 031B0851D)

The role of the quinol dehydrogenase ImcH in *Geobacter sulfurreducens* energy metabolism

Américo G. Duarte*, Andreia Pimenta, Catarina M. Paquete, Renato M. Domingos, Inês A. C. Pereira

ITQB NOVA, Oeiras, 2780-157

*Email: americoduarte@itqb.unl.pt

Electroactive bacteria are strong candidates for new biotechnological applications, namely for energy production as bioelectricity in microbial fuel cell devices. The development of these devices is still a work in progress, with their practical implementation limited by low power densities or low production rates. To optimize the performance of the electroactive bacteria used in such devices, we must understand and improve their metabolism, specifically the mechanisms used for energy production.

Geobacter sulfurreducens is a model electroactive bacterium frequently used in electrochemical devices, due to the highly conductive biofilms it generates. It is capable of extracellular electron transport of electrons from carbon metabolism to the cell exterior, towards insoluble minerals or electrodes. Two proposed quinone-interacting membrane cytochromes, ImcH and CbcL, were proven to be essential for this extracellular electron transfer to high and low redox potential electron acceptors, respectively [1]. The CbcL-dependent pathway operates at or below redox potentials of -0.10 V vs the standard hydrogen electrode, whereas the ImcH-dependent pathway operates only above this value. Here, we provide evidence that *G. sulfurreducens* also requires different electron transfer proteins for reduction of a wide range of Fe(III). ImcH has an N-terminal membrane domain with three transmembrane helices and a C-terminal domain with seven c-type hemes.

In this work, we cloned, overexpressed and purified *G. sulfurreducens* ImcH. The recombinant protein was characterized using biochemical, spectroscopic and electrochemical techniques. Electron transfer experiments with ImcH and quinones are ongoing to understand its role in energy conservation and extracellular electron transfer.

Keywords: Anaerobic Respiration, Energy Metabolism, Quinol dehydrogenase,

Funding: Fundação para a Ciência e Tecnologia (Portugal) through grant PTDC/BIA-BQM/29118/2017 (to AGD and IACP) and R&D unit MOSTMICRO-ITQB (UIDB/04612/2020 and UIDP/04612/2020). European Union's Horizon 2020 research and innovation program (Grant agreement no. 810856).

Referenes

[1] C.E. Levar, C.L. et al. Redox potential as a master variable controlling pathways of metal reduction by *Geobacter sulfurreducens*, ISME J. 11 (2017) 741–752.

Voltammetric analysis of the extracellular electron transfer process: Diagnostic criteria for understanding and quantification.

Pérez-García, Jesús Alberto¹, Bacame-Valenzuela, Francisco Javier^{1,2}, Castañeda Zaldívar, Federico¹, Ortiz-Frade, Luis¹, Reyes-Vidal, Yolanda^{1,2*}.

¹ Centro de Investigación y Desarrollo Tecnológico en Electroquímica, Parque Tecnológico Querétaro, s/n, Sanfandila, 76703

² Consejo Nacional de Ciencia y Tecnología, Centro de Investigación y Desarrollo Tecnológico en Electroquímica, Parque Tecnológico Querétaro, s/n, Sanfandila, 76703

*Email: mreyes@cideteq.mx

A key factor in bioelectrochemical systems is the extracellular electron transfer (EET). This process occurs when electrogenic microorganisms (EM) receive or deliver electrons to conductive electrodes, according to their metabolic cycle. Currently, it is recognized that EM can use two pathways for EET: 1) direct extracellular electron transfer (EETD); 2) indirect extracellular electron transfer (EETI) [1]. In recent years, important advances have been made in understanding EET at the biological level. However, models are still needed to explain EET at the electrochemical level [2]. The development of equations through finite element analysis to simulate the electrochemical behaviour of EET in cyclic voltammetry is a strategy that allows us to understand biological processes at the electrochemical level (Fig. 1). This allows the quantification of important kinetic parameters such as the electron transfer rate, relationship between substrate consumption and microbial electrocatalysis, cell growth effects and others [3]. Therefore, the present work uses differential equations to simulate the EET in cyclic voltammetry, which allows proposing strategic experimental arrangements for the understanding and quantification of the EET.

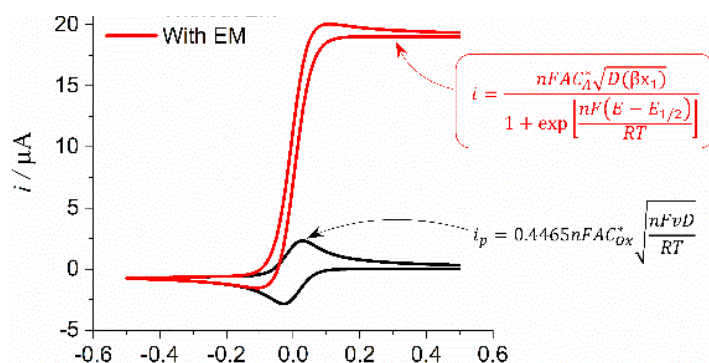

Fig. 1 Voltammetric profiles of a redox mediator and equations, in the presence and absence of EM [4].

Keywords: Voltammetric analysis, Electrochemical simulation, Extracellular electron transfer.

Funding: CONACYT-SENER-Sustentabilidad Energética (Project 246052) and CONACYT-SEP-Ciencia Básica (Project 258159).

References

[1] Schröder, U., et al. Microbial electrochemistry and technology: Terminology

and classification. *Energy & Environmental Science*, 2015, 8: 513–519.

[2] Guan, F., et al. Phenazine enables the anaerobic respiration of *Pseudomonas aeruginosa* via electron transfer with a polarised graphite electrode. *International Biodeterioration & Biodegradation*, 2019, 137: 8–13.

[3] Rousseau, R., et al. A theoretical model of transient

cyclic voltammetry for electroactive biofilms. *Energy & Environmental Science*, 2014, 7: 1079.

[4] Pérez-García J. A., et al. Microbial electrochemical technologies for wastewater treatment, in *The Future of Effluent Treatment Plants: Biological Treatment Systems*, 1st ed., M. Shah, S. Rodríguez-Couto, and K. Mehta, Eds. Elsevier, 2021, 287–306.

Effect of applied voltage on co-digestion of cattle manure and wastewater biosolids in Anaerobic Digestion-Microbial Electrolysis Cell (AD-MEC) systems

Mert Sanli, Yasin Odabas, Amin Ghaderikia, Yasemin Dilsad Yilmazel*

Department of Environmental Engineering, Middle East Technical University, Ankara Turkey

*Email: dilsad@metu.edu.tr

The application of integrated anaerobic digestion MEC (AD-MEC) system was studied for co-digestion of cattle manure (CM) and wastewater biosolids (WBS) composed of primary sludge and waste activated sludge. In the experimental design, three different voltages (0.3, 0.7 and 0.9 V) and different substrate mixing ratios were used in single chamber AD-MEC systems for enhanced methane production. The reactors consisted of conventional AD, open circuit, and applied potential reactors with different CM to WBS mixing ratios of 100:0, 30:70, 70:30 and 0:100. Reactors were operated in duplicate under mesophilic conditions (35 °C) with no mixing, and current production was monitored continuously throughout the study. Results showed that, there was no significant impact of applied voltage on methane production in the WBS reactors, yet in CM reactors applied voltage showed a significant enhancement on methane production. Methane yield of CM reactors at an applied voltage of 0.9V was 684.19 mL CH₄/g VS_{removed} which is about 1.85 times higher than conventional AD reactors (370.28 mL CH₄/g VS_{removed}) and 1.37 times higher than OC reactors (500.98 mL CH₄/g VS_{removed}). Integrated AD-MEC system fed with CM presents a significant opportunity to enhance the effectiveness of conventional AD systems with a relatively simple modification.

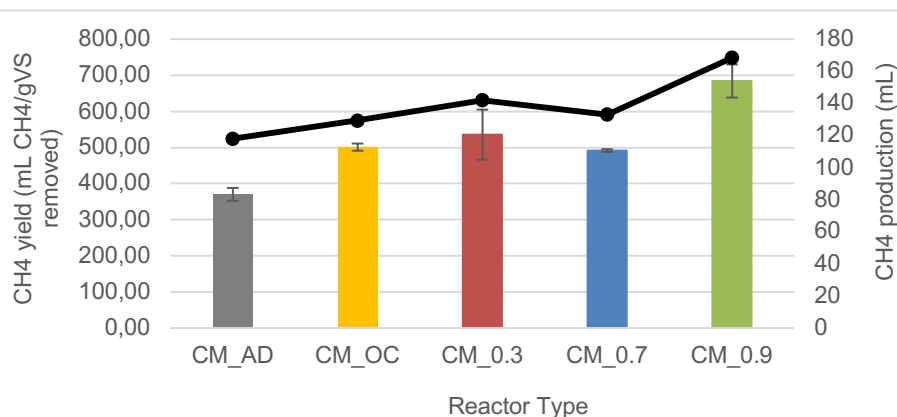

Fig. 1 Methane yield graph for cattle manure reactors (bar chart shows yield, line shows production)

Keywords: co-digestion, methane, cattle manure, microbial electrolysis cell, AD-MEC system

Funding: This study was funded by The Scientific and Technological Research Council of Turkey (TUBITAK)

(No: 217M854)

Converting the offgas of hydrothermal carbonization into methane by means of electromethanogenesis

G. Pelaz^{1*}, J. Arias¹, A. Morán¹, A. Escapa^{2}**

¹ Chemical and Environmental Bioprocess Engineering Group, Natural Resources Institute (IRENE), University of León, Avda. Portugal 41, León 24009, Spain.

² Department of Electrical Engineering and Automatic Systems, Campus de Vegazana s/n, Universidad de León, E-24071 León, Spain

* gpelg@unileon.es ** adrian.escapa@unileon.es

Hydrothermal carbonization (HTC) is a sustainable and cost-effective solution for waste biomass management. The gaseous phase resulting from HTC of organic waste is mainly composed of CO₂ (between 85 and 95 vol.%) and traces of other gases such as CO, CH₄, N₂ or H₂. This gas is usually seen as a waste stream and released into the atmosphere. Valorising this CO₂-rich waste stream through electromethanogenesis would avoid GHG emissions while adding extra value to the overall bioprocess. In the present work, HTC offgas effectively substituted CO₂ gas in the feeding of mixed-cultures biocathodes poised at -1V vs. Ag/AgCl. HTC offgas exhibited a certain negative effect on the electrochemical part of the process, decreasing current density and maximum methane yield by 44.2% and 17.5% respectively. Removing the applied electrical potential diminished methane yield by 91.1%, revealing the electrical dependence of the process.

Keywords: Bioelectrochemical systems, Hydrothermal carbonization, Electromethanogenesis, Biocathode

Co-metabolism of benzene and glucose in microbial fuel cells by synthetic communities

Natalia Tyszkiewicz¹, Grzegorz Pasternak^{1*}

¹ Laboratory of Microbial Electrochemical Systems, Department of Process Engineering and Technology of Polymer and Carbon Materials, Faculty of Chemistry, Wrocław University of Science and Technology, Wybrzeże Stanisława Wyspiańskiego 27, 50-370, Wrocław, Poland

*Email: grzegorz.pasternak@pwr.edu.pl

Soil and groundwater environments are often exposed to contamination by benzene, which is toxic and carcinogenic. Microbial Fuel Cell (MFC) technology can be employed in biodegradation of this pollutant, generating electricity as a by-product¹.

The aim of this study was to investigate the optimal composition of microbial consortia made up of pure bacterial cultures isolated from environments contaminated with petroleum products. Biodegradation of benzene and glucose was investigated in single-chamber MFCs. Five different, both gram negative and positive bacteria were used: *Pseudomonas aeruginosa*, *Streptococcus pyogenes*, *Shewanella putrefaciens*, *Pseudomonas spp.* and unidentified strain *LSK*. Inoculum was prepared in MSM medium with 0,07% benzene and 0,1% glucose concentration.

The growth dynamics of microorganisms was observed by real-time voltage monitoring and linear sweep voltammetry measurements of individual MFC electrodes using Ag/AgCl as the reference electrode. The highest power density was observed in MFCs dominated with: *Pseudomonas aeruginosa* 5,383 W/m³, while the lowest value was observed in MFC dominated with *LSK* strain: 0,6909 W/m³. The NMR analysis of the anolyte samples indicated, that both of the substrates – glucose and benzene were utilised by microorganisms. Nevertheless, analysis of metabolic profiles of each community revealed predominance of fermentation products, which indicated strong presence of non-electrogenic pathways.

Keywords: benzene-degrading microorganisms, MFC, co-metabolism, pure culture

Funding: This work was supported by the Polish National Agency for Academic Exchange – Polish Returns grant (PPN/PPO/2018/1/00038) and National Science Centre (Poland) OPUS grant (2019/33/B/NZ9/02774)

References

- [1] Aburto-Medina, A. & Ball, A. S. Microorganisms involved in anaerobic benzene degradation. *Ann. Microbiol.* **65**, 1201–1213 (2015).

Synthesis of biosurfactants from waste vegetable oil in air-cathode microbial fuel cell

Aleksander de Rosset¹, Grzegorz Pasternak^{1,*}

¹ Wrocław University of Science and Technology, Laboratory of Microbial Electrochemical Systems, Department of Process Engineering and Technology of Polymer and Carbon Materials, Wybrzeże Wyspiańskiego 27, 50-370 Wrocław

*Email: grzegorz.pasternak@pwr.edu.pl

Microbial fuel cells (MFC) are devices that use microorganisms as biocatalysts for the oxidation of organic matter to generate electricity and/or synthesise valuable compounds. One of the possible bioconversion products are biosurfactants that are of great interest due to their wide range of applications and unique properties. In this study, the potential of biosurfactants and electricity production from waste vegetable oil was assessed in single-chamber air-cathode microbial fuel cells. The MFC was investigated using surface tension measurements, real time temporal analysis, and linear and cyclic voltammetry measurements. The electroactive biofilm capable of conducting the process of biosynthesis once it reached stable current. The biosynthesis process has been noticeable after 5 weeks of feeding MFC's with waste cooking oil. In the anolyte, a decrease in surface tension to 47.9 mN m⁻¹ was reached, while at the same time, a maximum power density of 4.83 W m⁻³ was generated. In this study, we showed that simultaneous production of biosurfactants and electricity through electrofermentation process can be achieved by using waste vegetable oils in single-chamber system.

Keywords: Microbial fuel cell, waste vegetable oil, biosurfactants

Funding: This work was supported by the Polish National Agency for Academic Exchange – Polish Returns grant (PPN/PPO/2018/1/00038) and National Science Centre (Poland) OPUS grant (2019/33/B/NZ9/02774)

References

[1] Pasternak, G., Askitosari, T. D. & Rosenbaum, M. A. Biosurfactants and Synthetic Surfactants in Bioelectrochemical Systems : A Mini-Review Influence on Electron Transfer. 11, 1-9 (2020).

On the use of MEC technology to treat exhausted vine stock wastewater

D. Carrillo¹, R. Mateos¹, A. Morán¹, A. Escapa^{1,2,*}

¹ Chemical and Environmental Bioprocess Engineering Group, Natural Resources Institute (IRENA), Universidad de León, Avda. de Portugal 41, E-24009 Leon, Spain

² Department of Electrical Engineering and Automatic Systems, Campus de Vegazana s/n, Universidad de León, E-24071 León, Spain *

Email: adrian.escapa@unileon.es

In this work, we try to explore the ability of a single-chamber microbial electrolysis cell (MEC) to produce methane (CH_4) from an exhausted vine stock wastewater. Carbon felt electrodes were used as bioanodes and stainless steel as cathode (working volume of 0.5 L, see Fig. 1). The cell worked in a two-electrode configuration at an applied potential of 1 V with a feeding ratio of 30/70 (30% substrate to 70% synthetic medium). In addition, an identical MEC operated in open circuit was used as a control. Although carbon removal was similar in the two cells (in the range between 70 – 76%), biogas recovery was three times higher in the connected cell (17.1 L vs 6.0 L) along 10 cycles of operation (7 days per cycle), achieving CH_4 concentrations of up to 79%. In addition, the electrical capacitance of the connected anode doubled that of the non-connected cell (as measured using electrochemical impedance spectroscopy), containing 31% more Bacteria and 77% more Archaea. In summary, the results here reported ratify the advantages of using MEC for the treatment of organic liquid wastes.

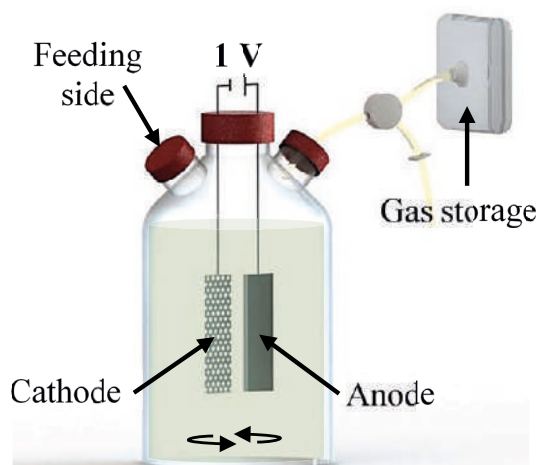

Fig. 1 Microbial electrolysis cell (MEC) configuration.

Keywords: Biogas recovery, methane, microbial electrolysis cell.

Funding: This research was possible thanks to the financial support by FEDER and Interreg V-A España-Portugal (POCTEP) 2014-2020. Project: Desarrollo de una estrategia transfronteriza para la valorización ecosostenible de biomásas residuales del sector vinícola y vitivinícola en Biorrefinerías integrales para la producción de Biocombustibles y Bioproductos. (No.0688_BIOVINO_6_E).

Prospecting for electrochemically-active hydrocarbon-degrading microorganisms for use in bioelectrochemical remediation of petroleum hydrocarbons.

Belinda Yoba'a Yayork, Amarachukwu Anyogu, Godfrey Kyazze

University of Westminster, 115 New Cavendish Street, London United Kingdom, W1W 6UW.

*Email: belindayayork@yahoo.com

Petroleum hydrocarbons pollution is commonplace in the environment owing to accidental spillages, leakages and indiscriminate disposal. Globally, it is estimated that between 1.7-8.8 million tonnes of oil is released into the aquatic environment annually; and from 1970-2018, 5.8 million tonnes of oil were spilled as a result of tanker incidences. Remediating these spills is a great priority due to their negative impacts on the environment e.g. irreversible habitat loss and threat to the survival of living organisms and public health e.g. genotoxic, mutagenic and/or carcinogenic effects.

Work is currently underway to enrich and select electrochemically active hydrocarbon degraders for use in bioelectrochemical remediation of target petroleum hydrocarbons – benzene and phenanthrene. Inocula from contaminated matrices (soil, sediment and groundwater) was taken from the Niger Delta region, Nigeria, which was highlighted by a 2011 UNEP report as being highly contaminated with petroleum hydrocarbons. Selected isolates will be identified and inoculated into microbial fuel cell as pure cultures and as microcosms to determine their hydrocarbon removal efficiencies and rates.

Bioelectrochemical remediation has promise in speeding up the degradation process while reducing the amount of energy and chemicals used both of which are current impediments to conventional bioremediation processes applied to petroleum hydrocarbons.

Keywords: Bioelectrochemical, Remediation, Environment, Petroleum, Pollution.

References

Dadrasnia, A., Agamuthu, P. (2013) Diesel fuel degradation from contaminated soil by *dracaena reflexa* using organic waste supplementation. *J. the Japan Petro. Inst.*, 56(4), 236-243.

Ghosal, D., Ghosh, S., Dutta, T.K., Ahn, Y. (2016). Current State of Knowledge in Microbial Degradation of Polycyclic Aromatic Hydrocarbons (PAHs): A Review. *Frontiers in Microbiology*. 7 1369.

International Tanker Owners Pollution Federation (ITOPF), (2019). Oil tanker spills statistics 2018. https://www.itopf.org/fileadmin/data/Documents/Company_Lit/Oil_Spill_Stats_2019.pdf Accessed on 27th May, 2020.

United Nations Environment Programme UNEP, (2011) Environmental Assessment of Ogoniland. <https://www.unep.org/explore-topics/disasters-conflicts/where-we-work/nigeria/environmental-assessment-ogoniland-report> Accessed on 30th June, 2020.

Potentiostatic enrichment of electroactive biofilm communities derived from soil contaminated with petroleum products

Bartosz Widera¹, Grzegorz Pasternak^{1*}

¹ Laboratory of Microbial Electrochemical Systems, Department of Process Engineering and Technology of Polymer and Carbon Materials, Faculty of Chemistry, Wrocław University of Science and Technology, Wybrzeże Stanisława Wyspiańskiego 27, 50-370, Wrocław, Poland

*Email: grzegorz.pasternak@pwr.edu.pl

The technology of bioelectrical systems is gaining increasing attention for its sustainability. These systems are capable of generating electricity, but also of treating various types of wastes. In principle, soluble wastes are readily accessible for microbial degradation, while insoluble, hydrophobic wastes reinforce particular MFC design and operation.

Our aim was to enrich electroactive biofilm from soil derived from petroleum-contaminated environment, capable of degradation of such compounds. The enrichment was done by using chronoamperometry, to accelerate the growth of biofilm at the anode. Customised BES design was built using a polypropylene chamber and acrylic lid supplied with sampling and reference electrode ports.

During the experimental period, the following anodic potentials were kept constant -0.3; 0,0 and 0,3 V (vs Ag/AgCl). After reaching stable, reproducible current, the cyclic voltammetry and linear sweep voltammetry were used to characterize electroactive biofilm. The observed maturing phase of biofilm growth lasted 8 weeks. The highest current was observed for the potential of -0.3 V, and reached approximately 100 μA . Two main oxidizing peaks were also detected during CV studies, their height was 27.1 μA (-0.230 V) and 158.6 μA (0.389 V). Thus, we have selected the most beneficial growth conditions for microorganisms degrading petroleum products.

Keywords: bioelectrochemical system, chronoamperometry, petroleum products

Funding: This work was supported by the Polish National Agency for Academic Exchange – Polish Returns grant (PPN/PPO/2018/1/00038) and National Science Centre (Poland) OPUS grant (2019/33/B/NZ9/02774).

References

- [1] Pasternak, G., Askitosari, T. D. and Rosenbaum, M. A. (2020) 'Biosurfactants and Synthetic Surfactants in Bioelectrochemical Systems: A Mini-Review', *Frontiers in Microbiology*, 11(March), pp. 1–9. doi:10.3389/fmicb.2020.00358
- [2] Zhou, L. *et al.* (2016) 'Microbial Electricity Generation and Isolation of Exoelectrogenic Bacteria Based on Petroleum Hydrocarbon-contaminated Soil', *Electroanalysis*, 28(7), pp. 1510–1516. doi:10.1002/elan.201501052.
- [3] He, Z. and Mansfeld, F. (2009) 'Exploring the use of electrochemical impedance spectroscopy (EIS) in microbial fuel cell studies', *Energy and Environmental Science*, 2(2), pp. 215–219. doi:10.1039/b814914c.

Unveiling the role of H₂ in the cathodic electron uptake by acetogenic bacteria

Muñoz, Laura¹; Vinther Grøn, Louise¹; Philips, Jo¹

¹Aarhus University, Høngøvej 2, 8200

*Email: Laura.munoz@bce.au.dk;

louise.groen@bce.au.dk

Some acetogenic bacteria have the capacity to use cathodes as electron donor for the reduction of CO₂ into acetate or other organic compounds. This capacity can be applied for innovative bioelectrochemical technologies, such as microbial electrosynthesis (MES). However, the rates of MES remain too low, while the mechanisms used by acetogens to take up cathodic electrons are still unclear.

We investigate the role of H₂ as an intermediate in the cathodic electron uptake by acetogens. We hypothesize that the capacity of acetogens to take up cathodic electrons depends on their H₂ consumption characteristics, including their H₂ threshold (1). We experimentally determined the H₂ threshold, i.e. the H₂ partial pressure at which acetogenesis halts, of several acetogenic strains. We found the highest H₂ thresholds for acetogenic *Clostridia*, while *Acetobacterium* spp. had lower H₂ threshold. The lowest H₂ thresholds were found for *Sporomusa* spp. These H₂ thresholds inversely correlate with cathodic electron uptake rates described in literature: highest MES rates for *Sporomusa* spp. for which we found the lowest H₂ threshold. We will further investigate if and how the H₂ partial pressure maintained by the acetogens at the cathode surface affects the cathodic H₂ evolution rate.

Keywords: acetogens, H₂ thresholds, extracellular electron transfer mechanisms, cathodic H₂ evolution, microbial electrosynthesis (Up to 5 keywords, Font: Arial, 10.5 pt.)

Funding: Starting Grant of the Aarhus University Research Fund (AUFF)

References

- (1) Philips, J. (2020) 'Extracellular Electron Uptake by Acetogenic Bacteria: Does H₂ Consumption Favor the H₂ Evolution Reaction on a Cathode or Metallic Iron?', *Frontiers in Microbiology*, 10, pp. 1–13. doi: 10.3389/fmicb.2019.02997.

Stimulating Biofilm Formation of *Sporomusa ovata* for Improved Attachment on Cathode in Microbial Electrosynthesis

Grøn, L. V.^{1*}, Muñoz, L. D.¹, Jensen, T. S.¹, Koren, K.¹ & Philips, J.¹

¹ Aarhus University, Nordre Ringgade 1, 8000, Denmark

*Email: louise.groen@bce.au.dk

In microbial electrosynthesis, acetogenic bacteria reduce CO₂ to organic compounds using a cathode as electron donor. Microbial electrosynthesis rates remain low and need to be improved. We hypothesize that improved biofilm formation and higher cell numbers on the cathode can increase microbial electrosynthesis rates.

We performed adaptive evolution with a selection pressure for biofilm formation on *Sporomusa ovata*, an acetogen well known for its microbial electrosynthesis activity. In a long-term serial transfer experiment, *S. ovata* was grown in a H₂/CO₂/N₂ headspace on plastic carriers incompletely covered by liquid medium. Activity was followed by measuring the decrease in headspace pressure (indicating consumption of H₂ and CO₂). At regular time intervals, one or two carriers were transferred to bottles with fresh carriers and fresh medium. By transferring only *S. ovata* cells sticking to the transferred carriers, a selection pressure for biofilm formation was created.

After eight serial transfers, this resulted in an adapted population of *S. ovata*, which has a significant higher biofilm formation than the initial strain, based on crystal violet assays in well plates under heterotrophic conditions. In addition, we will present results of microbial electrosynthesis activity by the adapted *S. ovata* and its biofilm formation on the cathode.

Keywords: Microbial Electrosynthesis, Biofilm, Adaption, Acetogens

Funding: Novo Nordisk Fonden Biotechnology-based Synthesis & Production Research. Project Grant 'Let them stick'.

Random genetic mutagenesis in *Geobacter Sulfurreducens* induces high cytochrome activity to tolerate with hexavalent chromium

Md Tabish Noori^{1,2*}, Juan Manuel Ortíz², Abraham Esteve Nunez^{1,2}

¹ Department of Chemical Engineering, University of Alcala, Alcala De Henares, Spain – 28805

² IMDEA Aqua, Alcala De Henares, Spain – 28805

*Email: md.noori@uah.es

Geobacter Sulfurreducens can reduce Cr (VI) by c-type cytochrome (c-Cysts). However, high concentration of Cr (VI) imparts lethal effect on *G. Sulfurreducens*, which moderates their cell metabolism. Thus, we improved Cr (VI) tolerance of wild type *G. Sulfurreducens* by chemically induced random mutagenesis. Selected *G. Sulfurreducens* mutants grew in medium containing 2-times higher concentration of Cr (VI) (0.2 mM) as compared to wild type. Mutated cells harvested at late exponential growth phase (0.7×10^7 CFU/ml) removed 90 % Cr (VI) from medium containing 0.5 mM Cr (VI) in 2.5 h with cell normalized rate of 1.3×10^{-9} mg/CFU.h, which was higher than the wild type (69 %, and 1.0×10^{-9} mg/CFU.h). We also analysed total Cr distribution in the system and noticed that a significant portion of total Cr was assimilated in the biomass as Cr (III), thus confirming biologically assisted Cr (VI) reduction. Both type of bacterial genes showed typical UV-VIS spectra with six coordinated low-spin hemes, however, the reduced c-Cysts absorption band was large in mutants. Cyclic voltammetry analysis showed large redox current response for mutants as compared to wild type, confirming high electron flux in mutants, which enhanced the bioreduction of Cr (VI).

Keywords: Bioreduction, *Geobacter sulfurreducens*, hexavalent Chromium, Mutagenesis

Funding: This project has received funding from European Union's Horizon 2020 research and innovation program under Marie Skłodowska grant agreement No. 754382

Electrobioremediation of aromatic hydrocarbons using downflow METland® technology

Eduardo Noriega^{1,2,*}, Ramón Esteve-Núñez¹, Juan M. Ortiz³, Abraham Esteve-Núñez^{2,3}

¹ METFILTER S.L., Carrión de los Céspedes, Sevilla, Spain, 41820

² Department of Analytical Chemistry, Physical Chemistry and Chemical Engineering, Universidad de Alcalá, Alcalá de Henares, Spain, 28805

³ IMDEA Agua, Alcalá de Henares, Spain, 28805

*Email: eduardo.noriega@edu.uah.es

The versatility of the electromicrobiology makes it suitable to face the most challenging environmental problems through electrobioremediation actions (Wang et al., 2020). In this context, METland® technology constitute a sustainable solution where concepts from Microbial electrochemical Technologies (MET) are integrated into constructed wetlands (Peñacoba et al., 2021) by replacing inert gravel with electroconductive granular material.

In this study, a heterogeneous mixture of hydrocarbons was treated in a lab-scale METLAND® operated downflow with a hydraulic loading rate of 265 mm d⁻¹. In this configuration oxygen was passively supplied with no energy cost and aerobic metabolism occurred in combination with anaerobic electroactive bacteria (Aguirre et al. 2020). The removal capacity of the treatment was determined by measuring COD, TOC and benzene and toluene as specific hydrocarbons (12ppm in inlet wastewater). Our results showed an effluent free of benzene & toluene after the treatment. The microbial community analysis (Illumina) of electrode-associated biofilm revealed the presence of halophiles like *Halomonas*, *Oceanicaulis* (consistent with the saline nature of our wastewater); and *Alishewanella*, *Pseudomonas*, *Parvibaculum*, *Azoarcus* and *Thauera* (known to degrade hydrocarbons or outcompete in hydrocarbon polluted sediments).

Keywords: Wastewater treatment, Hydrocarbons, Electroactive biofilters, Microbial electrochemical technologies

Funding: Eduardo Noriega was funded by an Industrial Doctoral Fellowship from Science Ministry (MICINN) REF: DIN2018-009782

References

- Wang, X., Aulenta, F., Puig, S., Esteve-Núñez, A., He, Y., Mu, Y., & Rabaey, K. (2020). Microbial electrochemistry for bioremediation. *Environmental Science and Ecotechnology*, 1, 100013.
- Peñacoba-Antona, L., Senán-Salinas, J., Aguirre-Sierra, A., Letón, P., Salas, J.J., García-Calvo, E., & Esteve-Núñez, A. (2021). Assessing METland® design and performance through LCA: techno-environmental study with multi-functional unit perspective. *Frontiers in Microbiology*. Provisionally Accepted.
- Aguirre-Sierra, A., Bacchetti-De Gregoris, T., Salas, J. J., De Deus, A., & Esteve-Núñez, A. (2020). A new concept in constructed wetlands: Assessment of aerobic electroconductive biofilters. *Environmental Science: Water Research and Technology*, 6(5), 1312–1323.

SMFC as a tool for the removal of hydrocarbons and metals in the marine environment: a concise research update

Gambino, Edvige ; Chandrasekhar, Kuppam; Nastro, Rosa Anna

Department of Biological Sciences, University of Naples "Federico II", Complesso Universitario di Monte Sant'Angelo, 4 Naples, Italy ; Department of Biotechnology, National Institute of Technology Warangal, Telangana-506004, India ; EN.TECH Italia srl, Naples Italy

Marine pollution is becoming more and more serious, especially in coastal areas. Because of the sequestration and consequent accumulation of pollutants in sediments (mainly organic compounds and heavy metals), marine environment restoration cannot exempt from effective remediation of sediments themselves. It has been well proven that, after entering into the seawater, these pollutants are biotransformed into their metabolites, which may be more toxic than their parent molecules. Based on their bioavailability and toxic nature, these compounds may accumulate into the living cells of marine organisms. Pollutants bioaccumulation and biomagnification along the marine food chain lead to seafood contamination and human health hazards. Nowadays, different technologies are available for sediment remediation, such as physicochemical, biological, and bio-electrochemical processes. This paper gives an overview of the most recent techniques for marine sediments remediation while presenting Sediment based Microbial Fuel Cells (SMFCs). We discuss the issues, the progress, and future perspectives of SMFCs application to the removal of hydrocarbons and metals in the marine environment with concurrent energy production. We give an insight into the possible mechanisms leading to sediments remediation, SMFCs energy balance, and future exploitation.

Bacteria Recognition-Extraction from Wastewater (BREW) for next generation microbial electrochemical technologies

**Jack Reeder¹, Matt Unthank², Liz Heidrich¹,
Marloes Peeters^{1,*}**

¹ Newcastle University, School of Engineering, Merz Court,
Claremont Road, NE1 7RU, Newcastle upon Tyne, UK

² Northumbria University, Department of Applied Sciences, Ellison
building, NE1 8ST, Newcastle upon Tyne, UK

*Email: marloes.peeters@newcastle.ac.uk

Performance of microbial fuel cells (MFCs) strongly depends on the anode, particularly on the attachment of (electro)active bacteria to this electrode. To target high costs and limited bacterial adhesion associated with carbon electrodes, we will use a technique referred to as molecular imprinting, which creates artificial cavities complementary to the template molecule [1]. The binding sites generated can be engineered to selectively extract the bacteria of interest (in this case *Geobacter* [2]) from wastewater, expecting improved colonisation will enhance the MFC's performance. This is complicated as a balance needs to be struck between polymers that can grab the bacteria while retaining the bacteria's ability to proliferate.

Bacterial imprinting is a template polymerisation technique; polymerisation occurs in the presence of bacteria [1]. Following extraction, binding sites remain on the surface that are complementary to the size, shape and chemical functionality of the target bacteria. It is possible to discriminate between different strains of bacteria due to the differences of antigens on the surface (such as proteins or sugar groups) that can interact with the binding sites in different ways [3]. An example of a bacterial binding site is depicted below for *S. aureus* and *E. coli*, indicating the binding site has the same shape and dimension as the original target.

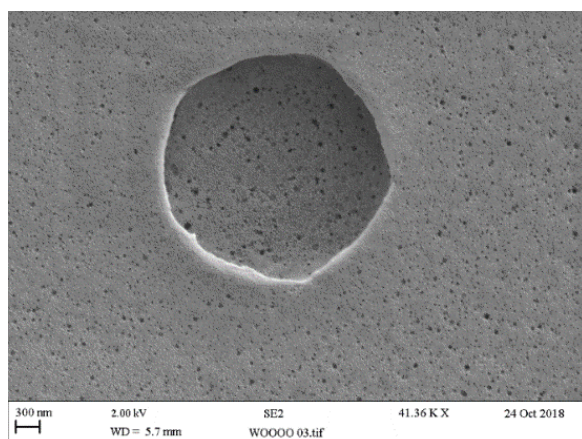
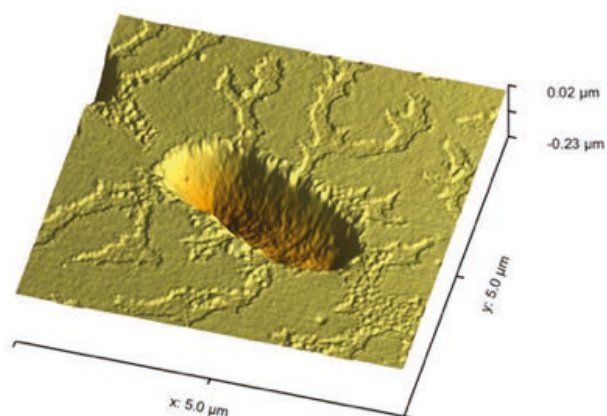

Fig. 1. (A) A typical binding site for *S. aureus* (visualised by scanning electron microscopy).



(B) Profile analysis of a cavity complementary to a single *E. coli* bacterium, made on glass (visualised by 3D atomic force microscopy) [4].

References

- [1] El-Schich, Z., Zhang, Y., Feith, M., Beyer, S., Sternbæk, L., Ohlsson, L., Stollenwerk, M. and Wingren, A.G., 2020. Molecularly imprinted polymers in biological applications. *BioTechniques*, 69(6), pp.406-419.
- [2] Heidrich, E.S., Curtis, T.P., Woodcock, S. and Dolfing, J., 2016. Quantification of effective exoelectrogens by most probable number (MPN) in a microbial fuel cell. *Bioresource technology*, 218, pp.27-30.
- [3] Betlem, K., Mahmood, I., Seixas, R.D., Sadiki, I., Raimbault, R.L.D., Foster, C.W., Crapnell, R.D., Tedesco, S., Banks, C.E., Gruber, J. and Peeters, M., 2019. Evaluating the temperature dependence of heat-transfer based detection: A case study with caffeine and Molecularly Imprinted Polymers as synthetic receptors. *Chemical Engineering Journal*, 359, pp.505-517..
- [4] Cornelis, P., Givanoudi, S., Yongabi, D., Iken, H., Duwé, S., Deschaume, O., Robbens, J., Dedecker, P., Bartic, C., Wübbenhorst, M. and Schöning, M.J., 2019. Sensitive and specific detection of *E. coli* using biomimetic receptors in combination with a modified heat-transfer method. *Biosensors and Bioelectronics*, 136, pp.97-105.

Sense Fuet no són tapes: Bioelectrosynthesis scale-up and optimization - a fed-batch story

Luis F.M. Rosa¹, Jeannine Mayr², Antje Spiess²,
Falk Harnisch^{1*}

¹ Helmholtz-Zentrum für Umweltforschung GmbH - UFZ,
Permoserstraße 15 I, 04318, Leipzig, Germany

² Institute of Biochemical Engineering Technische Universität
Braunschweig, Rebenring 56, 38106 Braunschweig, Germany

*Email: falk.harnisch@ufz.de

Microbial electrosynthesis (MES) is a dynamic and exciting research area originating from the combination of microbiology and electrochemistry. To bring MES to industrial application, reactor infrastructure is needed that meets the requirements of both, biological and electrochemical engineering. Our upgrade kit for turning commercial bioreactors, based on batch stirred tank reactors (BSTR) into electrobioreactors, has been previously benchmarked [1] and was applied to a potential upcoming industrial process based on another industry work horse, *E. coli*, as a microbial bioelectrosynthesis chassis for the production of chiral building blocks for pharmaceutical industry, that was also recently demonstrated in small scale [2]. By optimizing the process conduction from batch to fed-batch processing in the 1L bioelectroreactors, we have increased the titer of (*R*)-1-phenylethanol produced from acetophenone to 12.8 ± 2.0 mM, with a demonstrated Coulombic efficiency of near to 100%, and further improvements are still possible!

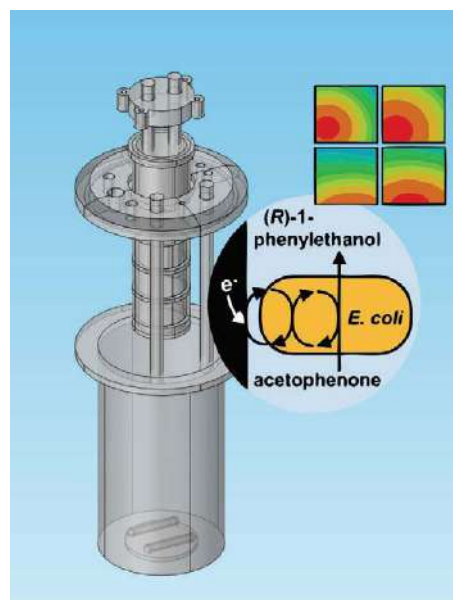

Fig. 1: Schematic depiction of the process/system.

Keywords: Bioelectrosynthesis, Electrobioreactor, Design of Experiments, Fed-Batch.

Funding: A.S. acknowledge the funding by the Deutsche Forschungsgemeinschaft (DFG, German Research Foundation) under Germany's Excellence Strategy – EXC 2163/1-Sustainable and Energy Efficient Aviation – Project-ID 390881007. F.H. acknowledges support by the Federal Ministry of Education and Research (Research Award "Next generation biotechnological processes-Biotechnology 2020+") and the Helmholtz-Association (Young Investigators Group). This work was supported by the Helmholtz Association within the Research Program Renewable Energies.

References

- [1] Rosa et al. (2016). Eng Life Sci. DOI: 10.1002/elsc.201600105
[2] Mayr et al. (2019). ChemSusChem. DOI: 10.1002/cssc.201900413

A Modelling Analysis of pH Change in Microbial Electrosynthesis (MES) Catholytes

Ellie Farmer¹, Da Li¹, Eileen Yu^{1,*}

¹ Loughborough University, Epinal Way, LE11 3TU

*Email: E.Farmer-17@student.lboro.ac.uk and eyu@lboro.ac.uk

Microbial electrosynthesis (MES) is an emerging technology for converting CO₂ to industrially useful organics by microbial catalysis. The study's main aim was to create a model of pH change in the MES catholyte, whose methodology can be used as a basis for the development of models with increasing accuracy for the prediction of experimental results.

The model achieves its aim through a reliable method for calculating pH based on relevant acid-base species concentration. A dynamic method using kinetic rate law, alongside reaction equilibrium, and stoichiometry is considered. Microbial processes are treated as a black box. It was found that all ions participating in acid-base reactions must be well considered to predict pH change in MES. Fluxes through membranes, particularly the flux of acetic acid, should be included for a more accurate fit with experimental results. Then, kinetic rate constants should be chosen to fit with experimental results through a rigorous trial and error process.

Sensitivity analysis on the impact of coulombic efficiency and hydraulic retention time (HRT) on pH found that a continuous system may be advantageous over batch for maintaining optimum pH. Model results found significantly lesser fluctuation in pH over 7 days using a continuous system, even at HRT of over 10 days for modelled parameters.

These results imply that the use of continuous operation over batch could allow for control and optimisation of organic production rates. The findings show that further investigation of pH change in MES through modelling would allow cost-effective and time-efficient targeting of MES experimentation, accelerating technology readiness levels.

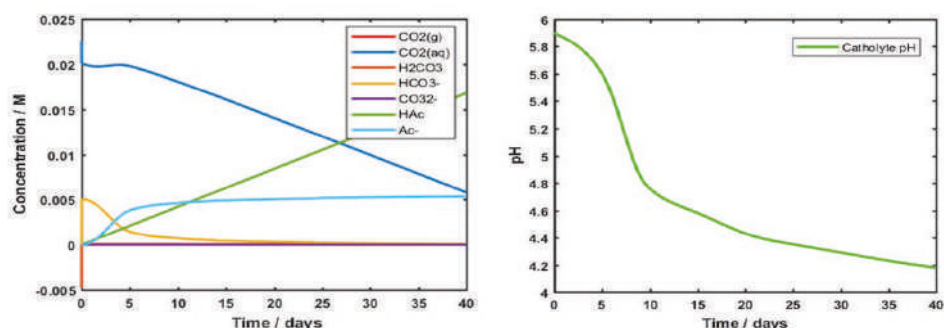

Figure 1 Model output plots for 40 days with a current density at $0.5 \times 10^{-3} \text{ A cm}^{-2}$. A Coulombic efficiency of 0.1 over a period of 40 days was applied
A) Plot of concentration of key species concentration (M) against time
B) Plot of pH against time.

Key words: MES, acid-base reactions, pH change, Hydraulic retention time

Funding: **EPSRC** EP/N009746/1, EP/R021503/1 and **EP/V011863/1**, NERC MeteoRR (NE/L014246/1) and NBIC 002POC19034, **EPSRC** Summer vacation studentship

References

- [1] Izadi, P., et al., *npj Biofilms and Microbiomes*, 2020. 6(1): p. 40.
- [2] Izadi, P., et al., *Faraday Discussions*, 2021.

Electrochemical behaviour of carbon nanofiber/PDMS composite used as a corrosion –resistant coating for copper in microbial fuel cells

Fatma BENSALAH ^{1,2}, Naoufel Haddour ¹, Kamel Khirouni ², Francois Buret ¹

¹Univ Lyon, Ecole Centrale de Lyon, INSA Lyon, Université Claude Bernard Lyon 1, CNRS, Ampère, UMR5005, 69130 Ecully, France

²Laboratoire de Physique des Matériaux et Nanomatériaux appliquées à l'Environnement, Faculté des Sciences de Gabès, Université de Gabès, 6072, Tunis

*Email: fatma.bensalah@ec-lyon.fr

Surface modifications of electrode materials are essential for improving the performance of microbial bio-electrochemical systems [1]. The use of copper (Cu) to functionalize electrodes as anodes in microbial fuel cells (MFCs) is a new process to improve their interfacial electron transfer, biocompatibility, and corrosion resistance. Cu anodes are prepared by surface modification with a composite made of polydimethylsiloxane (PDMS) doped with commercially carbon nanofiber (CNF). In our study, four-Cu anodes with CNF-PDMS with different thicknesses have been tested in MFCs. Three MFCs are equipped with modified Cu by CNF-PDMS with a thickness of 250 μm , 500 μm , and 1000 μm , respectively, and one MFC uses Cu anodes unmodified. The electrical characterization demonstrates that the maximum power density generated by MFCs with Cu / CNF-PDMS anodes is more stable. The Cu /CNF-PDMS electrode with a thickness of 500 μm shows the best performance. The cyclic voltammetry measurement indicates that the electrochemical activity of the modified anode significantly increases after ten days and that the electron transfer is facilitated by CNF-PDMS modification. These results prove that CNF-PDMS modification with an optimal CNF-PDMS thickness is a donating approach for improving the properties of anodic materials for applications in MFCs.

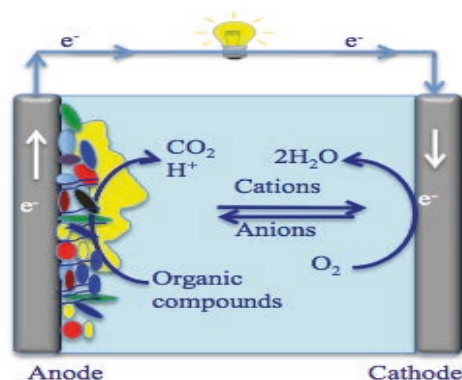

Fig. 1. Microbial fuel cells principle

Keywords: microbial fuel cell (MFC), CNF, PDMS, anode functionalization, corrosion resistance, biofilm

Funding: The "Hubert Curien Program" through the PHC MAGHREB Project number 19MAG23/41382WC financially supported this work.

References

- [1] Logan, Bruce E., et al. "Microbial fuel cells: methodology and technology." *Environmental science & technology* 40.17 (2006): 5181-5192.
- [2] Saadi, Meriem, et al. "Stainless steel coated with carbon nanofiber/PDMS composite as anodes in microbial fuel cells." *Materials Research Express* 7.2 (2020): 025504.

Whole bacterial cell surface modified screen printed nitrate biosensor based on direct electron transfer of *Bacillus* sp. electropolymerized within polyaniline films

Hossam E. M. Sayour¹, Nashwa Youssef², Ihab Adly³, Hani Ragai⁴, Khaled Kirah⁴, Ola M. Gomaa^{5*}

¹Molecular Biomimetic Research Group, Biomedical Chemistry Unit, Chemistry Dept., Animal Health Research Institute (AHRI), Agricultural Research Center (ARC), Dokki-Egypt, 12618

²Solid State Physics and Accelerators Department, National Center for Radiation Research and Technology, Egyptian Atomic Energy Authority, Cairo-Egypt, 11371

³Faculty of Engineering, British University in Egypt (BUE), Suez desert road, El Sherouk City-Egypt, 11837

⁴Faculty of Engineering, Ain Shams University, Cairo-Egypt, 11517

⁵Radiation Microbiology Department, National Center for Radiation Research and Technology, Egyptian Atomic Energy Authority, Cairo-Egypt, 11371

*Email: olagomaa4@gmail.com

Screen printed electrode (SPE) sensing is low cost, precise, rapid, sensitive and provide easy in situ quantification (1). Electropolymerization of whole bacterial cells (WBC) on SPE offers a constitutive expression system where the target analyte is sensed and the signal is converted to a measurable output (2). In the present work, *Bacillus* sp. possessing a periplasmic nitrate reductase was used as a recognition element to develop a nitrate biosensor. The bacteria was embedded within polyaniline electroconductive matrix via electropolymerization on miniaturized carbon screen printed electrodes (SPE) at 100 mV/sec and scan rate from -0.35 V to +1.7 V. Characterization was performed through different transduction modes (cyclic voltammetry, chronoamperometric of cathodic current, and impedometric spectroscopy). Optimal bacterial density was OD₆₀₀ 1.3. The developed sensor showed sensitivity over different working pHs (5-8) with wide dynamic linear detection range 0.5-50 ppm NO₃-N. It showed acceptable reproducibility and multiple usage up to 4 times after storage at 4°C over a duration of 2 months. Low cost and simple preparation allows the biosensor to be mass produced as a disposable point of care device (POCD) for water analysis. *Bacillus* sp. cells immobilized polyaniline is a good candidate for the improvement of amperometric biosensors for quantification of nitrate in aqueous solutions.

Keywords: Screen Printed Electrode, *Bacillus* sp., Nitrate, Whole Bacterial Cell Biosensor, Polyaniline

Funding: This work is part of ERANETMED3 project funded by Science Technology and Development Fund # 31321

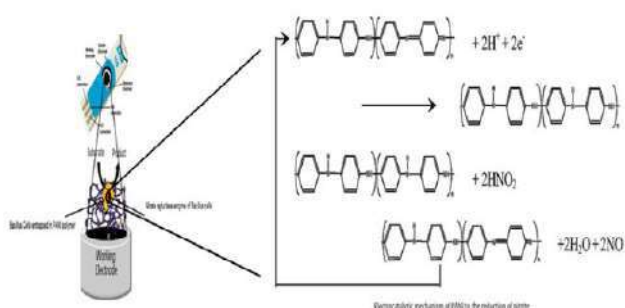

Fig. 1 Biomimetic electrochemical sensor based on *Bacillus* doped in PANI on the surface of SPE for nitrate detection

References

- [1] Ferrari A, et al. Screen printed electrodes: Transitioning the laboratory in-to-the field. *Talanta*, 2021, 3:100032.
- [2] Moraskie M, et al. Microbial whole-cell biosensors: Current applications, challenges, and future perspectives, 2021, 191:113359.

Microbial Electrochemical Snorkel (MES) for Nitrate Reduction

Joanna Rogińska^{1*}, Michel Perdicakis¹, Marc Hebrant¹, Julien Tournebize², Cédric Chaumont², Christelle Despas¹, Mathieu Etienne¹

¹ Université de Lorraine, CNRS, LCPME, 405 Rue de Vandoeuvre, F-54600 Villers-lès-Nancy, France

² UR HYCAR, Université de Paris Saclay, INRAE, centre d'Antony, 92761, Antony Cedex, France

*Email: joanna.roginska@univ-lorraine.fr

MES is a short-circuited Microbial Fuel Cell which operates at the maximum current for effective water treatment. The electrons released in the oxidation of organic matter by bioanodic side of MES are transported by solid electrode to the biocathodic side, where they are used to reduce electron acceptor (Fig. 1). Several applications were studied, such as enhancing wastewater treatment [1].

Here, we built a MES consisting of stainless steel electrodes placed in sediment and in wastewater. Keeping the proper ratio between anodic and cathodic parts allows to reach the specific potential [2] which for nitrate-reducing MES should be adequately low (in literature between -100 and -300 mV vs SHE) [3]. Our MES had the potential always in this negative range, with no external potential applied. The reactor was open to air, so oxygen - competing electron acceptor - was present. The addition of nitrate ($C_0 = 33.8 \text{ mg N-NO}_3\text{-/l}$) caused increase of current from -0.5 mA to -1.5 mA which decreased when nitrate was consumed, therefore it was corresponding to nitrate reduction. The nitrate-reduction peak was observed on the CV, beginning at +0.25 V vs SHE (Fig. 2). The nitrate reduction rate was increased in the presence of MES.

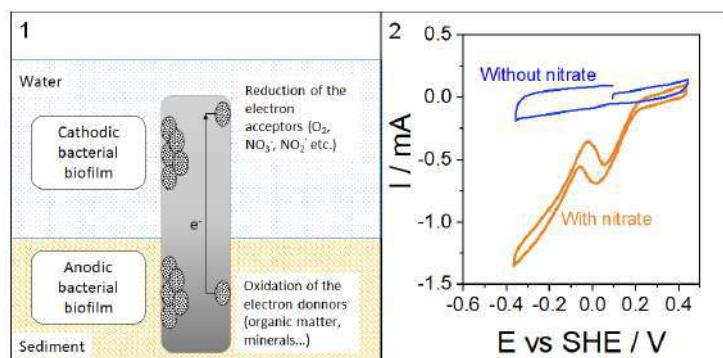

Fig. 1 The scheme of a MES.

Fig. 2 The cyclic voltammetry of a biocathode without (blue) and with (orange) nitrate.

Keywords: Microbial Electrochemical Snorkel, Microbial Fuel Cells, Biocathode, Denitrification

Funding: Financial support from The French National Research Agency (ANR-17-CE04-0004) is gratefully acknowledged.

References

- [1] Hoareau M, Erable B, Bergel A. Microbial electrochemical snorkels (MESs): A budding technology for multiple applications . A mini review. *Electrochem commun* 2019,104,106473.
- [2] Rogińska J, Perdicakis M, Midoux C, et al. Electrochemical analysis of a microbial electrochemical snorkel in laboratory and constructed wetlands. *Bioelectrochemistry*, *article in press*
- [3] Clauwaert P, Rabaey K, Aelterman P, et al. Biological denitrification in microbial fuel cells. *Environ Sci Technol* 2007,41,3354–60.

Comparison of different air cathode designs

Peter Babiak^{1*}, Geoffrey Schaffer-Harris¹, Marsel Murzabaev¹, Mami Kainuma¹, Yuka Miyafusa², Igor Goryanin¹

¹ Okinawa Institute of Science and Technology, 1919-1 Tancha, Onna, Kunigami District, Okinawa 904-0495 Japan

² Toyo Ink SC Holdings Co. Ltd. 1-22-1 Kaga, Itabashi-ku, Tokyo 173-0003 Japan

*Email: peter.babiak@oist.jp

Air cathode is basic part of MFC or MFC/biosensor devices. If air cathode is rate limiting step in MFC, bioanode cannot breathe properly. It can lead to decrease metabolic activity and low COD, VFA removal rate. In case of MFC type biosensor weak air cathode will decrease detection limit of sensor.

We compared two types of air cathodes: 1st design developed in our lab for wastewater treatment using hydrogel cation exchange membrane (CEM) on ceramic support [1] separating bioanode from catalyst **Fig 1a**. 2nd air cathode with diffusion layer design, made by Toyo Ink, where catalyst is in direct contact with bioanode part of reactor **Fig 1b**. The comparison was made by measuring linear sweep voltammetry.

Both designs have advantages and disadvantages. In 1st case catalyst is protected by membrane from anolyte solution which can lead to longer half-life of catalyst (no bio-fouling) and air cathode is mechanically strong, which is allowing to use it for scale up projects. But proton flux is limited by membrane properties. In 2nd case catalyst layer is in direct contact with anolyte and oxygen flux is limited only by oxygen diffusion layer, but this air cathode is difficult to use in scaleup projects.

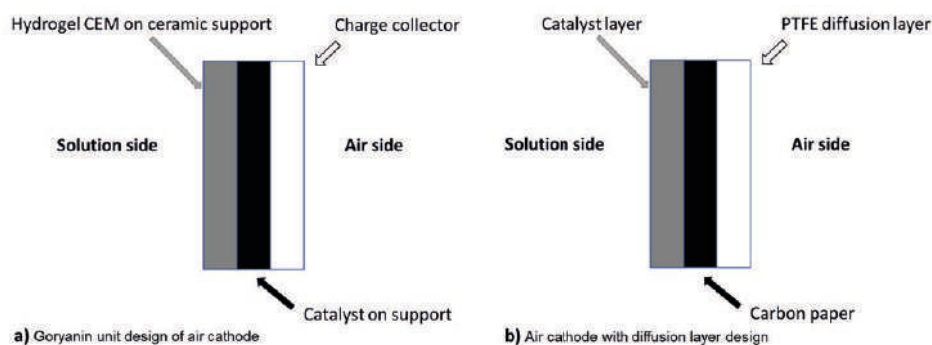

Fig. 1

Keywords: Air cathode, MFC, Scale up

References

[1] Separator of a microbial fuel cell, WO 2019/160046

[2] Joshua Middaugh, Updated by Shaoan Cheng and Wenzong Liu, How to Make Cathodes with a Diffusion Layer for Single-Chamber Microbial Fuel Cells, https://sites.psu.edu/microbialfuelcells/files/2019/09/Cathode_093008.pdf



Technical Secretariat
ALO CONGRESS, S.L.

C/ Numancia, 73, 7º C2 - 08029 - Barcelona - Phone: (+34) 933 633 954
secretary@euismet2021.eu



Sponsors & Collaborators

5th EU-ISMET ONLINE
5th European Meeting of the International Society
for Microbial Electrochemistry and Technology
13rd - 15th September 2021

Sponsors



Supporters

